

ECE2210 Final given: Spring 12

1. (20 pts) Find the values below. Show your work.

- a) $R_5 = ?$
- b) $V_S = ?$
- c) $P_S = ?$

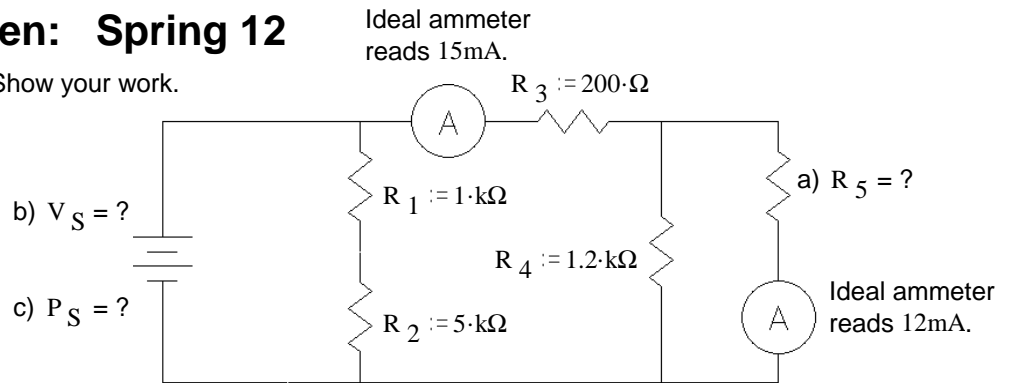

2. (15 pts) a) Find the s-type transfer function of the circuit shown. Consider I_{in} as the input and V_C as the "output".

You **MUST** show work to get credit. Simplify your expression for $H(s)$ so that the denominator is a simple polynomial with no coefficient before the highest-order s term in the denominator.

- b) How many zeroes does this transfer function have? If it has 1 or more, express them (probably in terms of R_1, R_2, R_3, L and C).
- c) How many poles does this transfer function have?

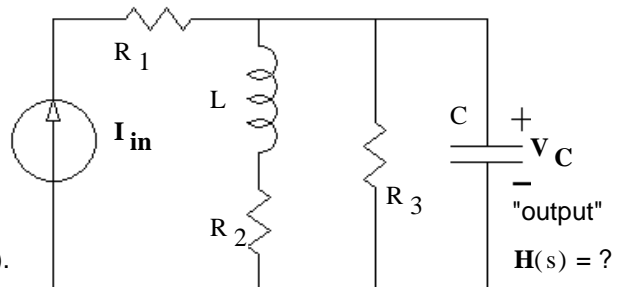

3. (26 pts) a) The switch has been open for a long time and is closed (as shown) at time $t = 0$.

- a) Find the initial and final conditions and write the full expression for $v_C(t)$, including all the constants that you find.
- b) What is v_C when $t = 1.5\tau$? $v_C(1.5\tau) = ?$
- c) At time $t = 1.5\tau$ the switch is opened again. Find the complete expression for $v_C(t')$, where t' starts when the switch opens.

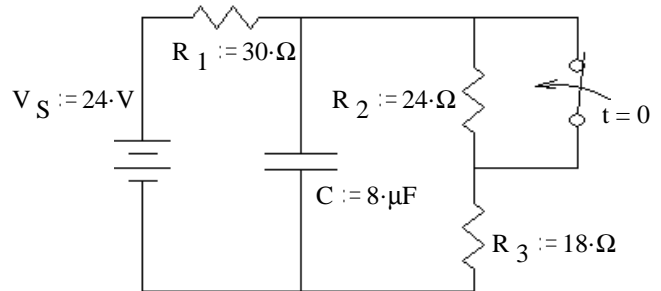

ECE2210 Final given: Spring 12 p2

4. (30 pts) A transformer is rated at 500V / 200V, 0.8kVA. Assume the transformer is ideal and all voltages and currents are RMS.

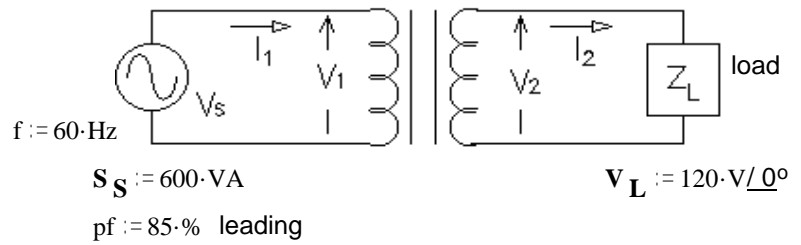

- The primary has 250 turns of wire. How many turns does the secondary have?
- The the load voltage, $V_L = 120 \cdot V$
How big is the source voltage ($|V_S|$)?
- The source supplies 600VA of apparent power at a power factor of 85%. Find the primary current, I_1 (magnitude **and angle**).
- Find the secondary load, Z_L (magnitude **and angle**). e) What is the load as seen by V_S ? (magnitude **and angle**)
- How much average power does the load dissipate?
- How much average power does the power source (V_S) supply?
- Is this transformer operating within its ratings?
How do you know? (Specifically show a values which are or are not within a correct range.)
- Using the given load voltage and power factor, what is the smallest load impedance magnitude that you could hook to this transformer and still operate within its ratings? $|Z_{Lmin}| = ?$
- Z_L is that found in part d). Add a component to the secondary side of the transformer so as to minimize the currents. Do not change the real power delivered to the load. Draw the part on the drawing and find its value.
- Is this transformer operating within its ratings with this new part?
How do you know? (Specifically show a values which are or are not within a correct range.)

5. (18 pts) The same input signal (at right) is connected to several op-amp circuits.

- Sketch the output waveform for this circuit. Clearly label important voltage levels on the output. If I can't easily make out what your peak values are, I'll assume you don't know. Don't forget to show inversions.

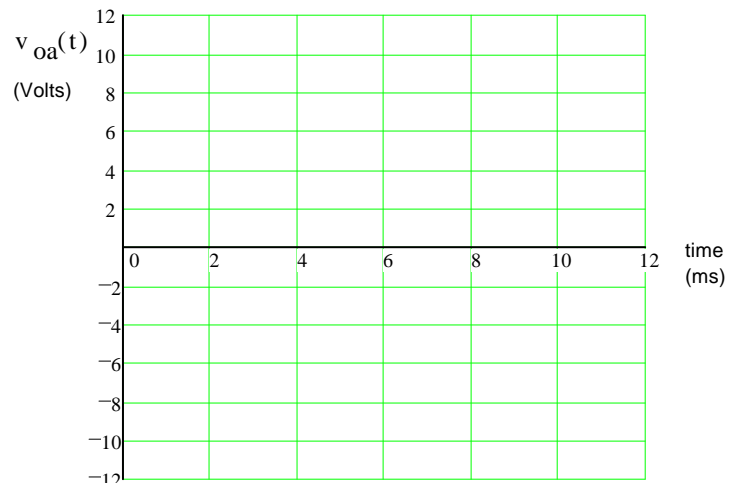
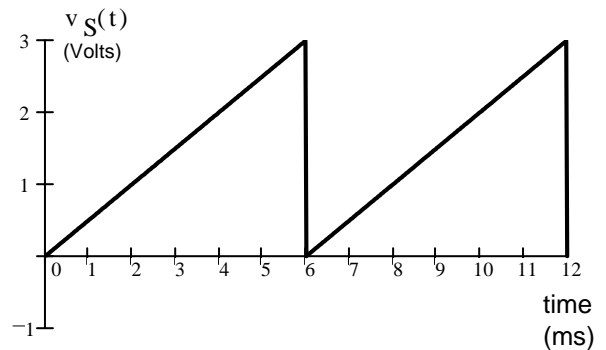
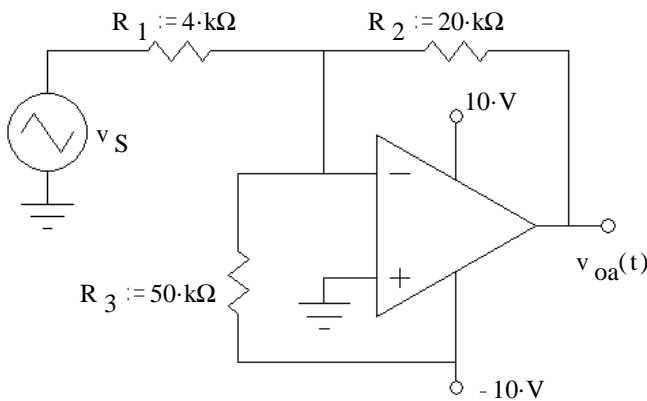

ECE2210 Final given: Spring 12 p3

5. b) Devise an op-amp circuit which will output the waveform shown below given the input waveform shown at right. Choose the power supplies and use whatever passive parts you need.

You **may not** use any other batteries, input signals, or power supplies beyond the two that power the op amp.

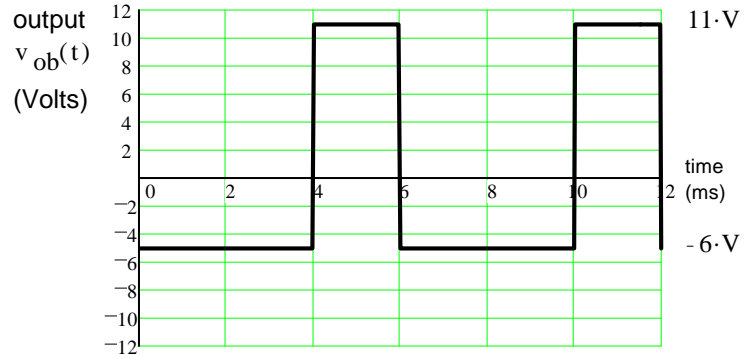
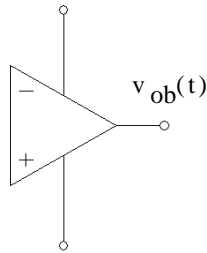
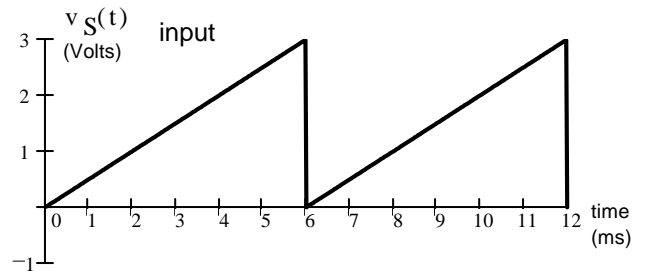

6. (26 pts) A couple of transistors are used to control the current flow through an inductive load. The switch has been closed, as shown, for a long time.

a) Assume both transistors are in saturation. Find the minimum β for transistor Q_2 . $\beta_{2min} = ?$

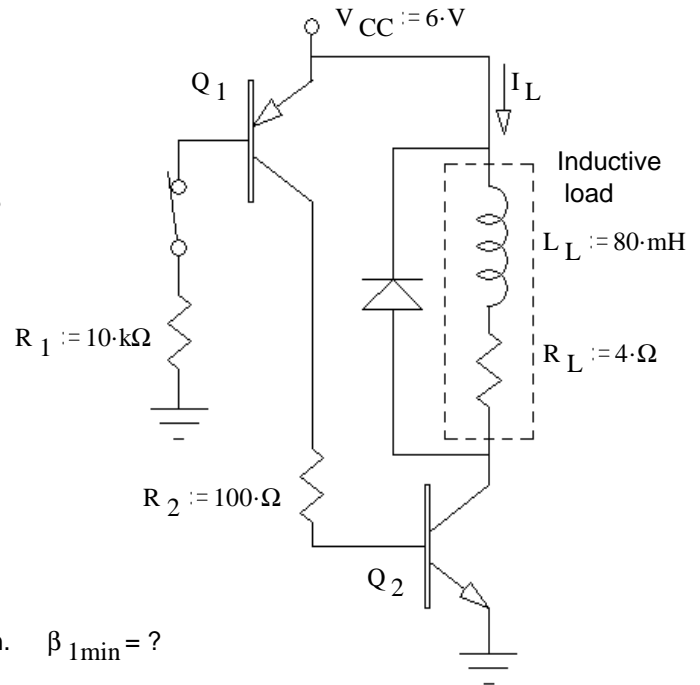

b) Find the minimum β for transistor Q_1 to be in saturation. $\beta_{1min} = ?$

c) Something is wrong. Transistor Q_2 is getting too hot. You measure the current through the load and find that $I_L = 800\text{mA}$. How much power is being dissipated in transistor Q_2 ?

d) Next you measure the voltage at the collector of Q_1 and find that $V_{C1} = 3.2\text{V}$ with respect to ground. Find the actual β s of both transistors and tell me what's wrong.

You replace the faulty component and everything is back to the way it was in part a)

e) The diode in this circuit conducts a significant current: (circle one)

- A) never.
- B) when the switch closes.
- C) whenever the switch is closed.
- D) always.
- E) when the switch opens.
- F) whenever the switch is open.

f) What is the maximum diode current you expect when the switch is cycled. (Answer 0 if it never conducts.)

7. (27 pts) Assume that diodes D_1 , D_2 and D_4 **DO conduct**.

Assume that diode D_3 does **NOT** conduct.

a) Stick with these assumptions even if your answers come out absurd. Find the following and anything else you need in order to check the assumptions:

$I_{R1} =$ _____

$V_{R4} =$ _____

$I_{D4} =$ _____

$I_{R2} =$ _____

$I_{D1} =$ _____

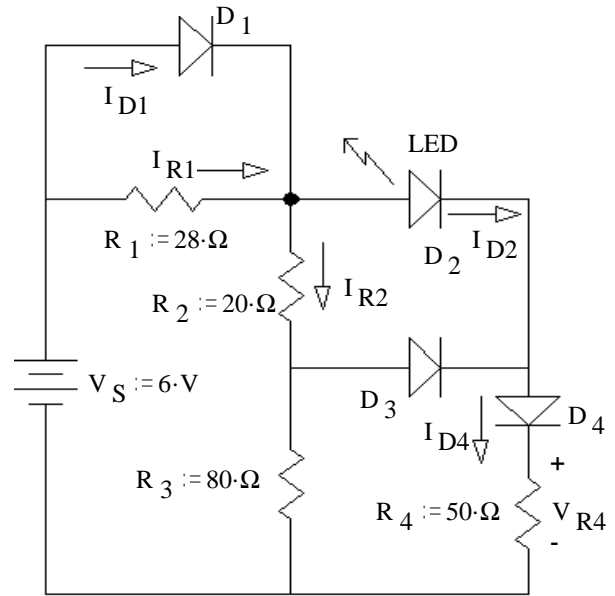

b) Based on the numbers above, was the assumption about D_1 correct? yes no (circle one)

How do you know? (Specifically show a value which is or is not within a correct range.)

c) Was the assumption about D_2 correct? yes no

How do you know? (Show a value & range.)

d) Was the assumption about D_3 correct? yes no

How do you know? (Show a value & range.)

e) Was the assumption about D_4 correct? yes no

How do you know? (Show a value & range.)

f) Based on your answers to parts b), c), d) & e), Circle one:

i) The **real** $I_{D4} < I_{D4}$ calculated in part a.

Justify your answer.

ii) The **real** $I_{D4} = I_{D4}$ calculated in part a.

iii) The **real** $I_{D4} > I_{D4}$ calculated in part a.

8. (18 pts) A voltage waveform (dotted line) is applied to the circuit shown. Accurately draw the output waveform (v_o) you expect to see. Label important times **and** voltage levels.

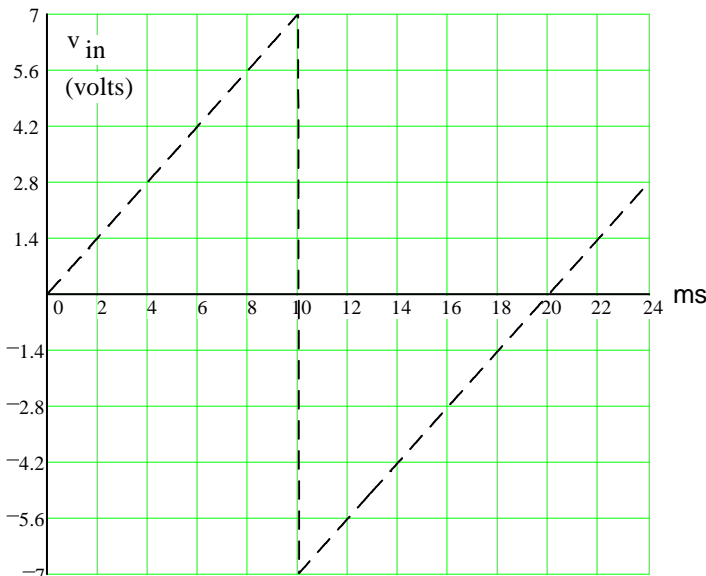

If you're not specific about your times and voltages, I'll assume you don't know !

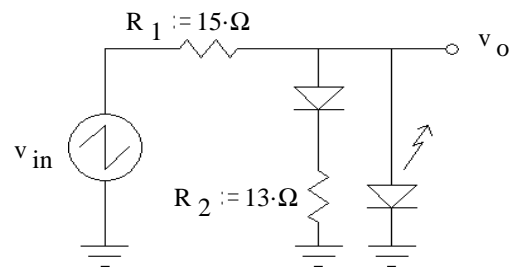

ECE2210 Final given: Spring 12 p5

9. Do you want your grade and scores posted on the Internet?
 If your answer is yes, then provide some sort of alias:

otherwise, leave blank

The grades will be posted on line in pdf form in alphabetical order under the alias that you provide here. I will not post grades under your real name. It will show the homework, lab, and exam scores of everyone who answers here.

Answers

1. a) $300 \cdot \Omega$ b) $6.6 \cdot V$ c) $106 \cdot mW$ 2. a)
$$\frac{\frac{1}{C} \cdot s + \frac{R_2}{L \cdot C}}{s^2 + \left(\frac{1}{R_3 \cdot C} + \frac{R_2}{L} \right) \cdot s + \frac{1}{L \cdot C} \cdot \left(\frac{R_2}{R_3} + 1 \right)}$$
 b) 1 $-\frac{R_2}{L}$
 c) 2

3. a) $9 \cdot V + 5 \cdot V \cdot e^{-\frac{t}{90 \cdot \mu s}}$ b) $10.12 \cdot V$ c) $14 \cdot V - 3.88 \cdot V \cdot e^{-\frac{t'}{140 \cdot \mu s}}$

4. a) 100 b) $300 \cdot V$ c) $2A \ / \ 31.8^\circ$ d) $24\Omega \ / \ -31.8^\circ$ e) $150\Omega \ / \ -31.8^\circ$ f) $510 \cdot W$ g) $510 \cdot W$
 h) NO i) $30 \cdot \Omega$ j) Add a $121mH$ inductor in parallel with the load k) Still NO

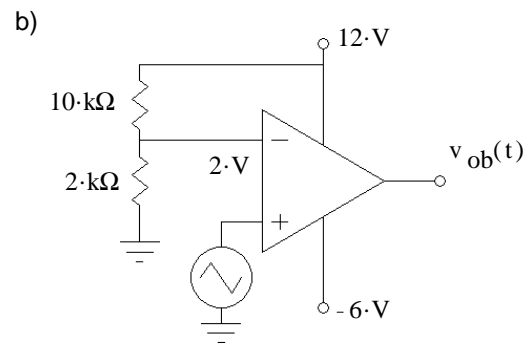
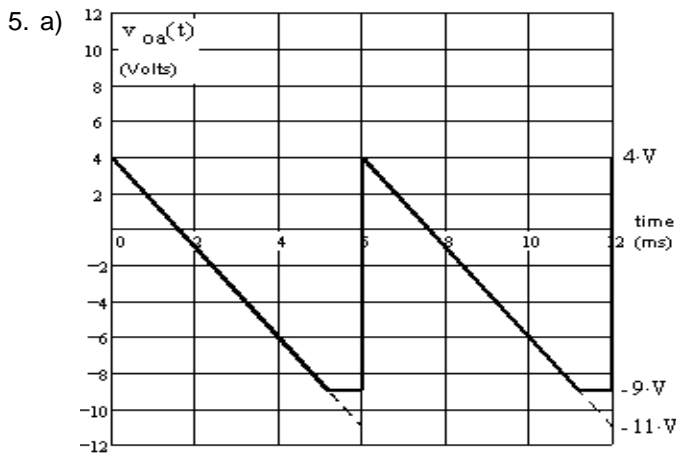

6. a) 28.4 b) 96.2 c) $2.24 \cdot W$ d) $\beta_2 := 32$ $\beta_1 := 47.2$ TOO LOW ! e) E)

7. a) $25 \cdot mA$ $2.6 \cdot V$ $52 \cdot mA$ $53 \cdot mA$ $80 \cdot mA$

b) yes $I_{D1} := 80 \cdot mA > 0$

c) yes $I_{D2} := 52 \cdot mA > 0$

d) no $V_{D3} := 0.94 \cdot V > 0.7V$

e) yes $I_{D4} := 52 \cdot mA > 0$

f) ii)

V_{D4} doesn't depend on the current through D_3

8.

