

ECE2210 Final given: Spring 08

Note: feel free to show answers & work right on the schematic

1. (18 pts) The ammeter, A, reads 30 mA.
 - a) The power dissipated by R_4 is 0.72 W, what is the value of R_4 . Assume that the ammeter is ideal (has no resistance).
 - b) What is the value of V_S ?
 - c) How much power is provided by the source?

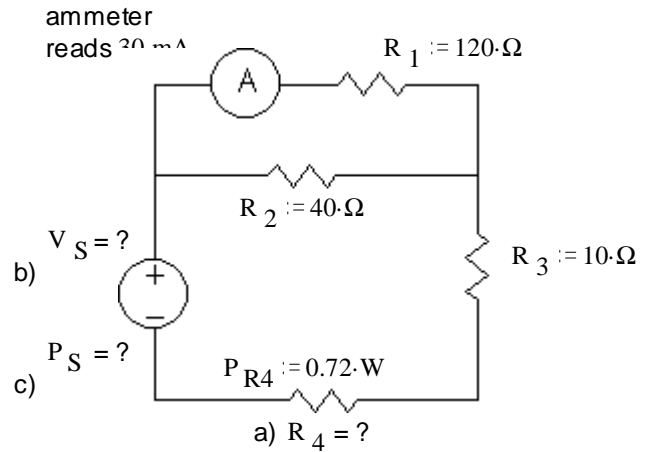

2. (17 pts)
 - a) Find: V_1 & I_2
 - b) I_S Supplies how much power to the circuit?

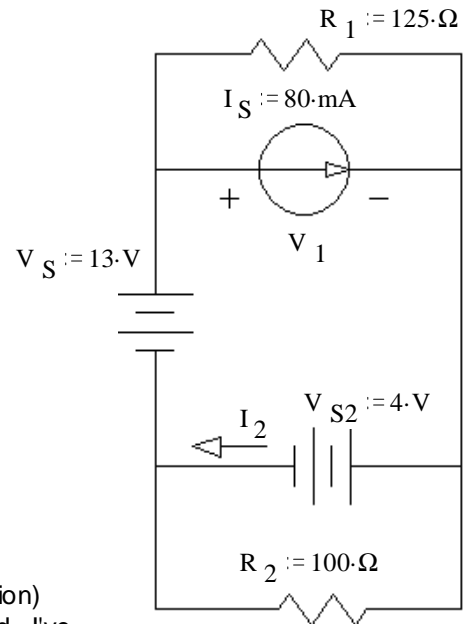

3. (17 pts) a) Draw the asymptotic Bode plot (the straight-line approximation) of the transfer function below. Accurately draw it on the graph provided. I've done the first section, you do the remainder.

You must show the steps you use to get the Bode plot. That is, show things like the corner frequency(ies), the approximations of the transfer function in each frequency region, calculations of dB, etc..

$$H(f) := \frac{100 \cdot (100 \cdot \text{Hz} + j \cdot f)}{(30 \cdot \text{kHz} + j \cdot f)}$$

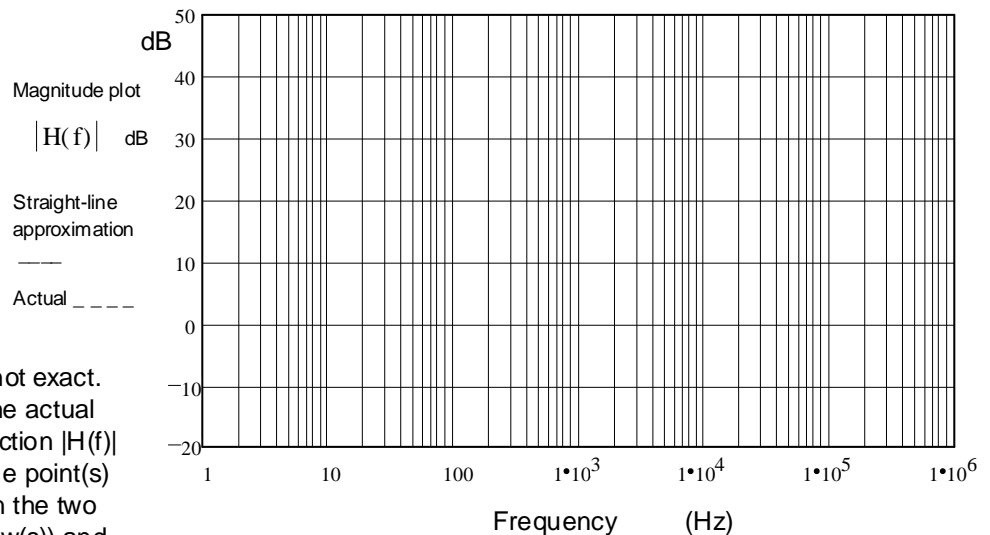

- b) The asymptotic Bode plot is not exact. Using a dotted line, sketch the actual magnitude of the transfer function $|H(f)|$ on the plot above. Indicate the point(s) where the difference between the two lines is the biggest (draw arrow(s)) and write down the actual magnitude(s) at that (those) point(s).
- c) If there are any corners in the Bode plot associated with **poles** in the transfer function, list that/those.
- b) If there are any corners in the Bode plot associated with **zeroes** in the transfer function, list that/those.

ECE2210 Final given: Spring 08 p2

4. (13 pts) Find:

a) The average, DC (V_{DC}) voltage.

b) The RMS (effective) voltage

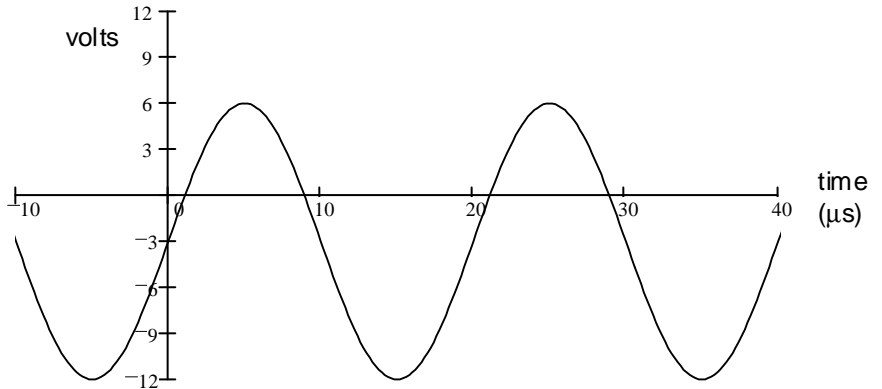

c) The voltage is hooked to a resistor, as shown, for 8 seconds.

How much energy is transferred to the resistor during that 8 seconds?

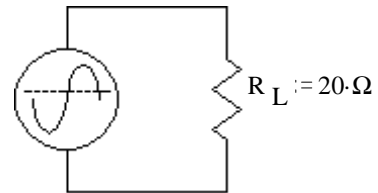

d) What happened to that energy?

5. (26 pts) Assume that diodes D_1 and D_2 **DO** conduct.

Assume that diode D_3 does **NOT** conduct.

a) Find I_{R3} , I_{D2} , I_{D1} , & V_{D3} based on these assumptions. Stick with these assumptions even if your answers come out absurd.

$I_{R3} =$ _____

$I_{D2} =$ _____

$I_{D1} =$ _____

$V_{D3} =$ _____

b) Based on the numbers above, was the assumption about D_1 correct? yes no (circle one)

How do you know?

(Specifically show a value which is or is not within a correct range.)

c) Was the assumption about D_2 correct? yes no (circle one)

How do you know?

d) Was the assumption about D_3 correct? yes no (circle one)

How do you know?

(Specifically show a value which is or is not within a correct range.)

e) Based on your answers to parts b), c) & e), Circle one: i) The **real** $I_{D2} < I_{D2}$ calculated in part a.

ii) The **real** $I_{D2} = I_{D2}$ calculated in part a.

iii) The **real** $I_{D2} > I_{D2}$ calculated in part a.

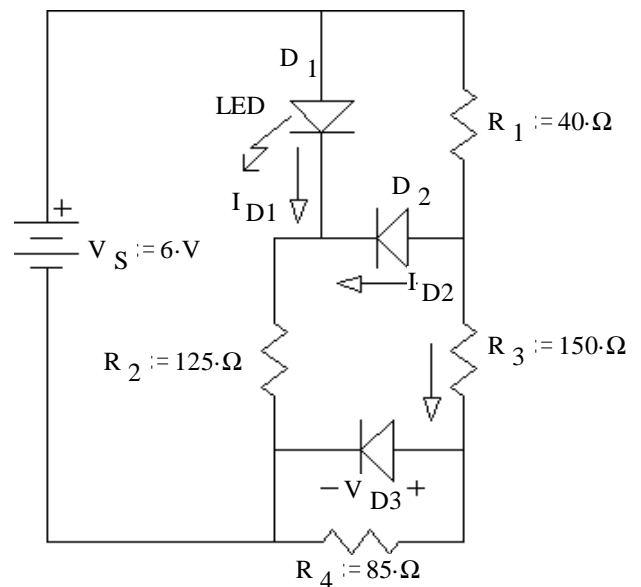

ECE2210 Final given: Spring 08 p3

6. (15 pts) A voltage waveform (dotted line) is applied to the circuit shown. Accurately draw the output waveform (v_o) you expect to see. Label important times and voltage levels.

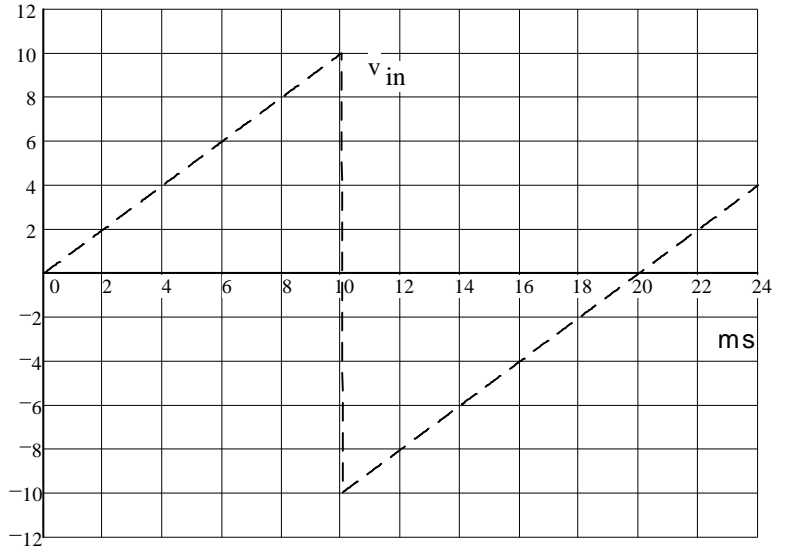
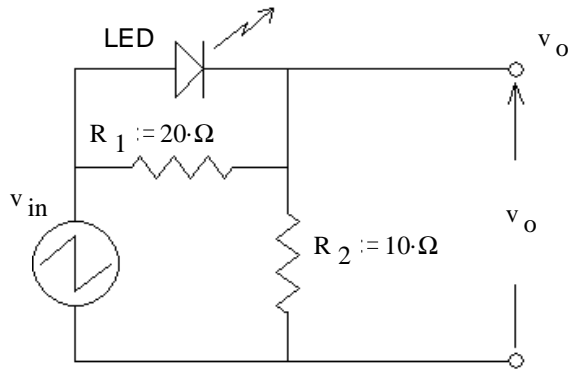

7. (25 pts) A transistor is used to control the current flow through an inductive load (in the dotted box, it could be a relay coil or a DC motor).

a) $\beta := 20$ Assume the switch has been open for a long time and the transistor is in the active region, find I_L , and V_{CE} and P_Q .

$I_L = ?$

$V_{CE} = ?$

$P_Q = ?$

b) Was the transistor actually operating in the active region?
yes no circle one

How do you know? (Specifically show a value which is or is not within a correct range.)

c) What minimum β would be required to achieve saturation?

d) You can't change the β . Find the maximum value of R_1 , so that the transistor will be in saturation.

e) The diode in this circuit conducts a significant current:

- A) never.
- B) when the switch opens.
- C) whenever the switch is open.
- D) when the switch closes.
- E) whenever the switch is closed.
- F) always.

(circle one)

f) R_1 is that found in part d). The switch is opened and closed a few times.

What is the maximum diode current you expect. (Answer 0 if it never conducts.)

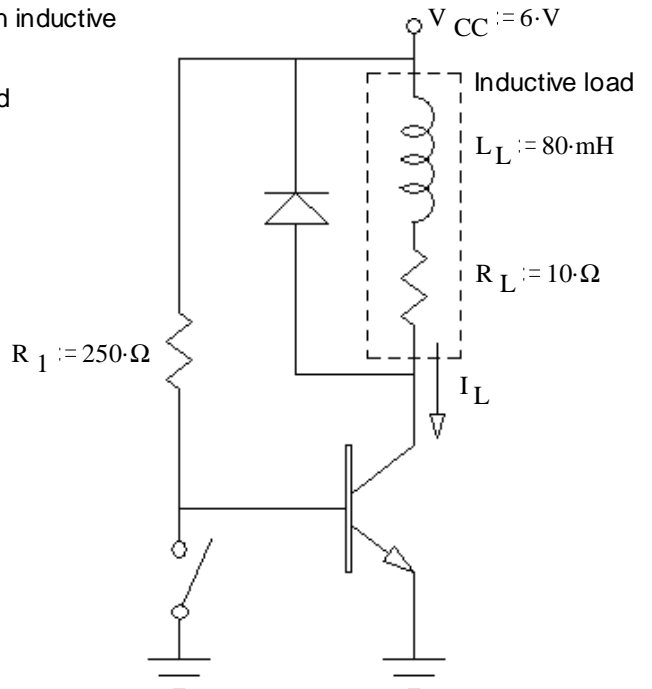

10 is Out of Order

10. Do you want your grade and scores posted on my door and on the Internet? Yes No (Circle one)

If your answer is yes, then provide some sort of alias or password: _____

The grades will be posted on my door in alphabetical order under the alias that you provide here. I will not post grades under your real name. The Internet version will be a pdf file which you can download. Both will show the homework, lab, and exam scores of everyone who answers yes here.

ECE2210 Final given: Spring 08 p4

7. (25 pts) The same input signal (at right) is connected to several op-amp circuits below. Sketch the output waveform for each circuit. Clearly label important voltage levels on each output. If I can't easily make out what your peak values are, I'll assume you don't know. Don't forget to show inversions. All op-amps are powered by ± 15 V power supplies.

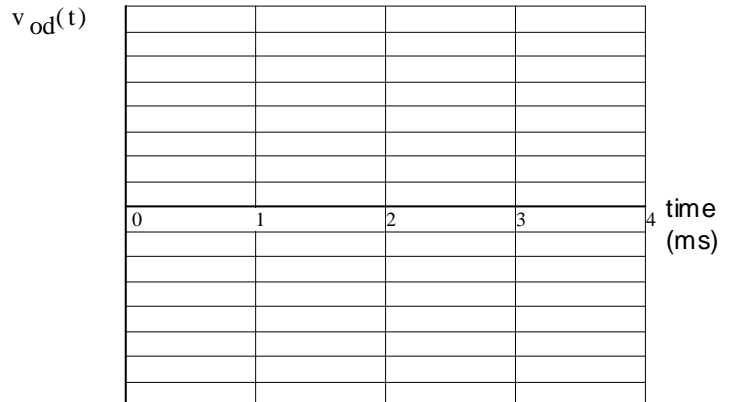
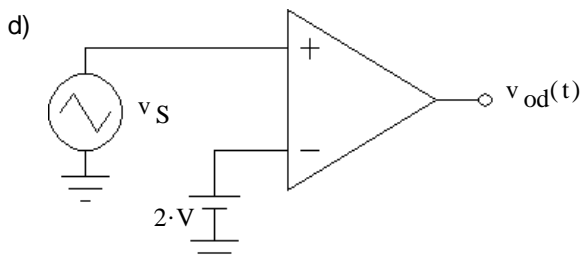
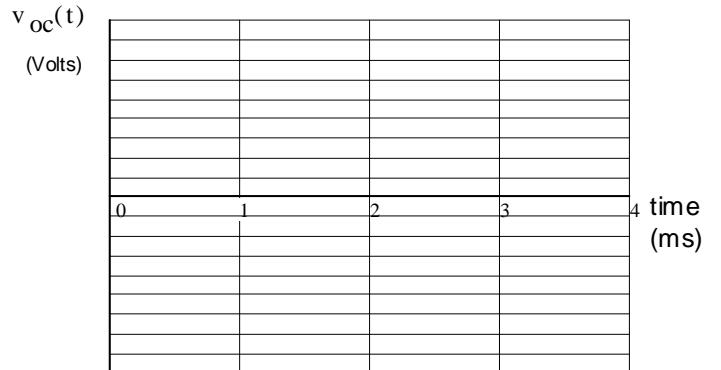
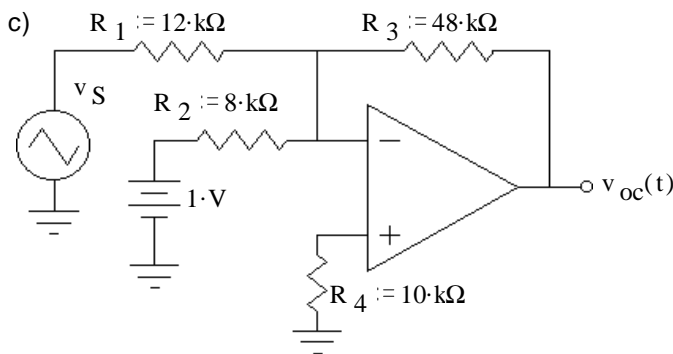
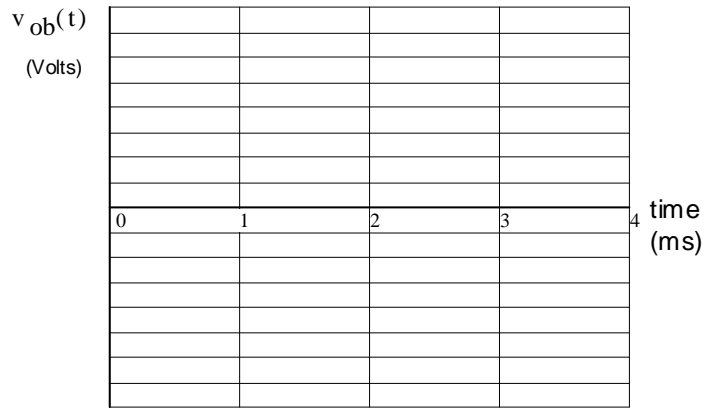
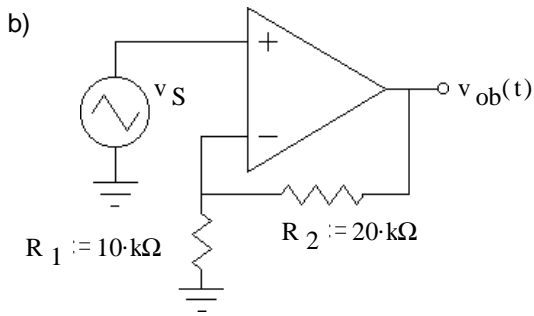
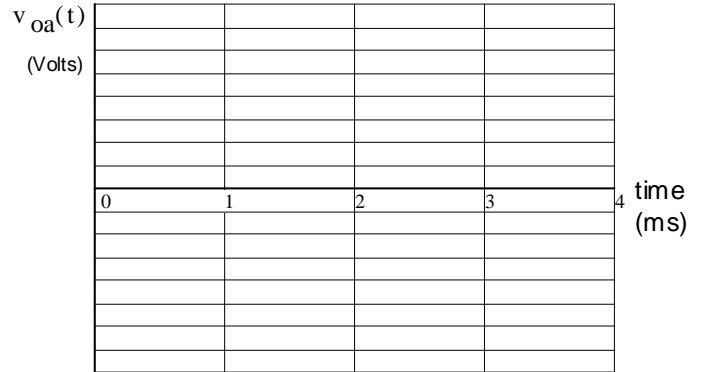
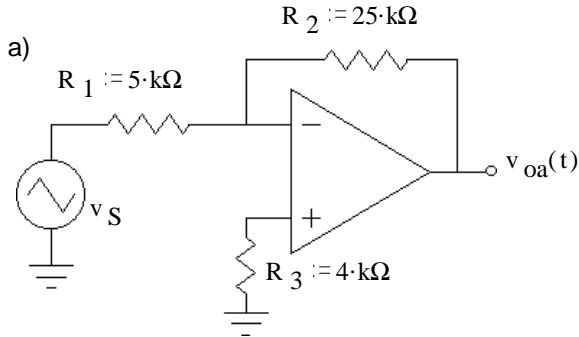
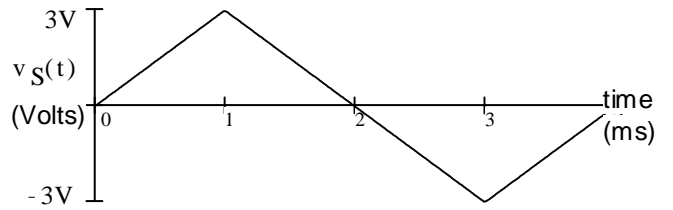

ECE2210 Final given: Spring 08 p5

9. (14 pts) a) Find the s-type transfer function of the circuit shown.

You **MUST** show work to get credit. Simplify your expression for $H(s)$ so that the denominator is a simple polynomial.

Hint: The "output" is a current and the input is a voltage. What is current over voltage?

$H(s) = ?$

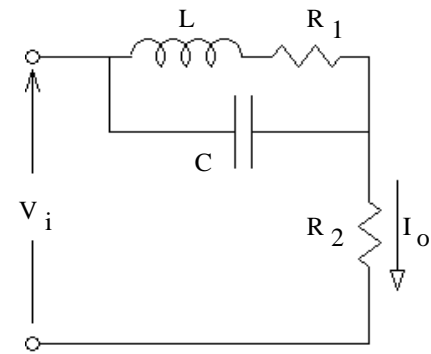

Answers

1. a) $50 \cdot \Omega$ b) $10.8 \cdot V$ c) $1.3 \cdot W$ 2. a) $9 \cdot V$ $112 \cdot mA$ b) $-720 \cdot mW$

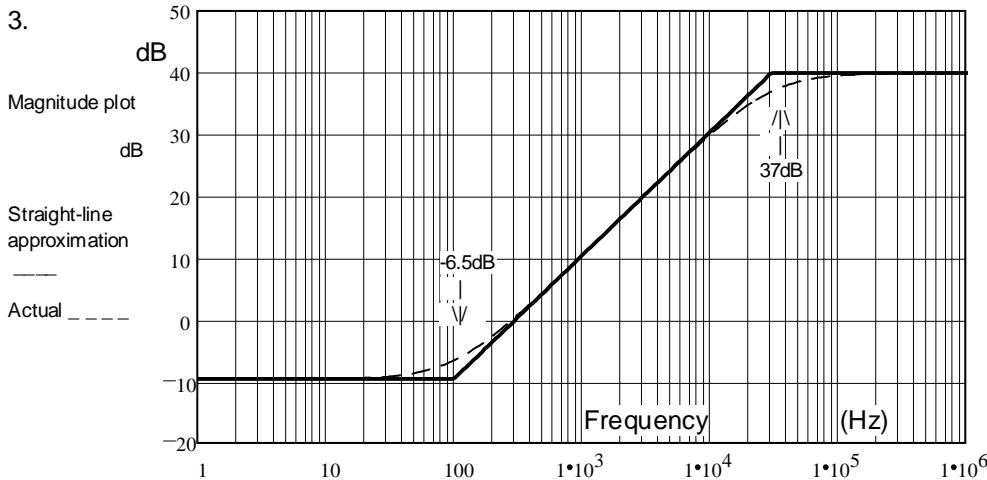

(negative because it absorbs power from the circuit)

3. b) $30 \cdot kHz$
c) $100 \cdot Hz$

4. a) $-3 \cdot V$
b) $7.04 \cdot V$
c) $19.8 \cdot J$
d) converted to heat

5. a) $20 \cdot mA$ $12.5 \cdot mA$ $19.5 \cdot mA$ $1.7 \cdot V$ 6.

- b) yes $I_{D1} = 20 \cdot mA > 0$
c) yes $I_{D2} = 12.5 \cdot mA > 0$
d) no $V_{D3} = 1.7 \cdot V > 0.7V$
e) i)

7. a) $424 \cdot mA$ $1.76 \cdot V$ $0.746 \cdot W$

- b) yes $V_{CE} = 1.76 \cdot V > 0.2 \cdot V$
c) 27.4 d) $183 \cdot \Omega$ e) D f) $580 \cdot mA$

8. a) Inverted triangle wave that would peak at $-15V$ and then at $+15V$, but is clipped at $-14V$ and $+14V$.

b) Triangle wave that peaks at $+9V$ and then at $-9V$.

c) Inverted $12V$ amplitude triangle wave offset by $-6V$. The negative peak would occur at $1ms$ and be $-18V$ but it is clipped at -14 . The positive peak occurs at $3ms$ and peaks at $+6V$, no clipping.

d) $-14V$ between 0 and $2/3ms$. $+14V$ between $2/3$ and $4/3ms$. $-14V$ between $4/3$ and $4ms$. Extra credit if you show slew effects.

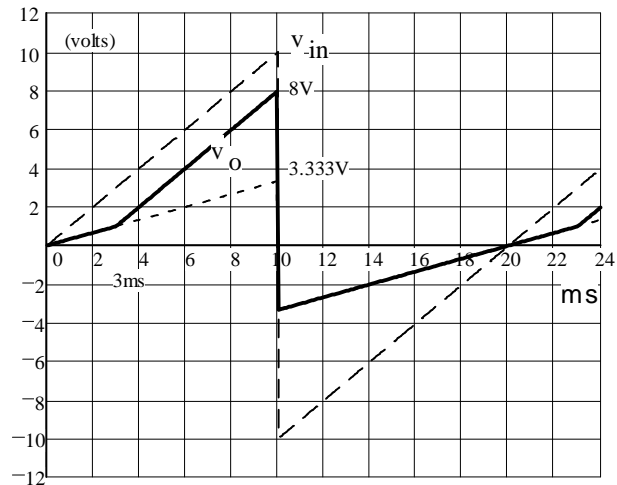

9.

$$\frac{\frac{1}{R_2} \cdot s^2 + \frac{R_1}{R_2 \cdot L} \cdot s + \frac{1}{R_2 \cdot L \cdot C}}{s^2 + \left(\frac{1}{R_2 \cdot C} + \frac{R_1}{L} \right) \cdot s + \left(1 + \frac{R_1}{R_2} \right) \cdot \frac{1}{L \cdot C}}$$