

ECE1050 Final given: Spring 04

(The space between problems has been removed.)

1. (26 pts) The switch has been closed for a long time and is opened (as shown) at time $t = 0$.

- Find the complete expression for $v_C(t)$.
- What is v_C after half a time constant? $v_C(\tau/2) = ?$
- After half a time constant time (at $t = \tau/2$) the switch is closed again. Find the complete expression for $v_C(t')$, where t' starts when the switch closes. Be sure to clearly show the time constant in this new expression.

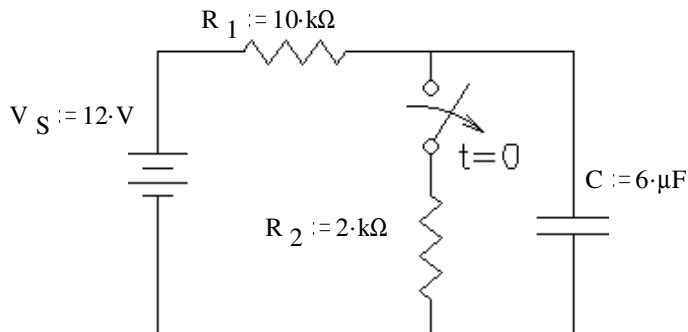

2. (17 pts) To get partial credit, show each step and each answer along the way.

- Find I_{in} in polar form.
- Find V_T .
- Circle 1:
 - The source current leads the source voltage.
 - the angle of I_{in} is greater than that of V_T

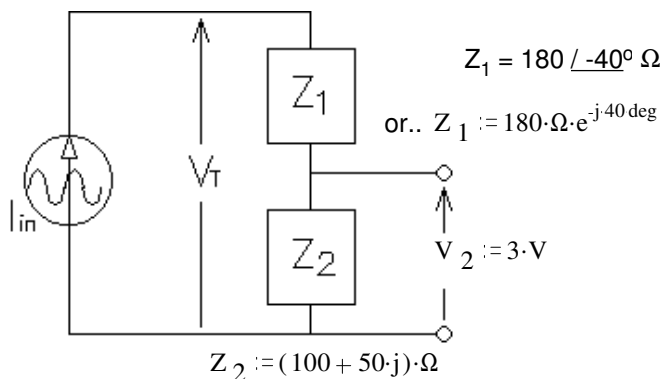

3. (28 pts) a) $\beta := 40$ Assume the transistor is in the active region, find I_C , and V_{CE} and P_Q .

$I_C = ?$

$V_{CE} = ?$

$P_Q = ?$

Was the transistor actually operating in the active region?

yes no circle one

How do you know? (Specifically show a value which is or is not within a correct range.)

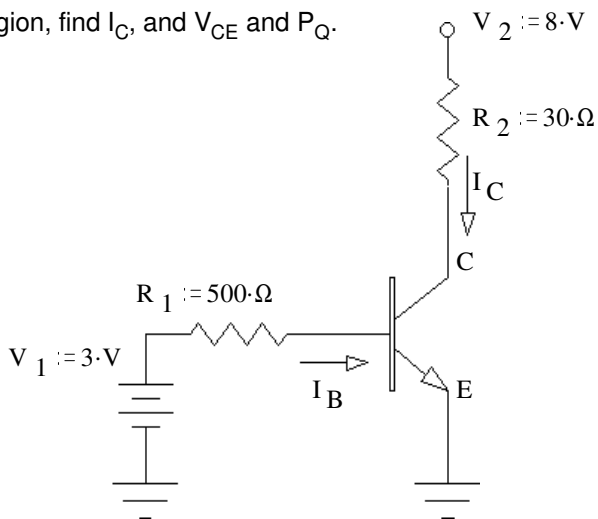

b) $\beta := 40$ find the maximum value of R_1 , so that the transistor will be in saturation.

c) $R_1 = 500\Omega$ and can't be changed, find the minimum value of β , so that the transistor will be in saturation.

4. (14 pts) For waveform shown, find:

a) Average DC (V_{DC}) value

b) RMS (effective) value

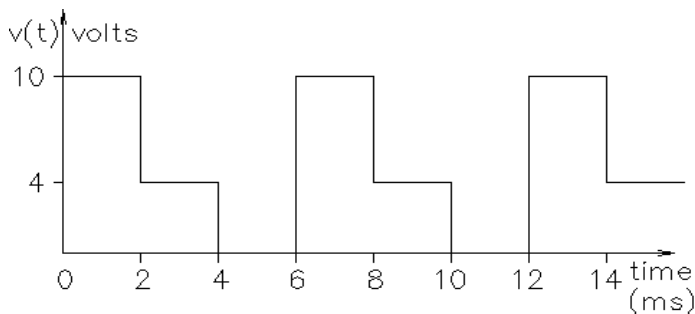

ECE1050 Final given: Spring 04 p2

5. (24 pts) R, & C together are the load in the circuit shown. The RMS voltmeter measures 208 V, the RMS ammeter measures 3 A, and the wattmeter measures 500 W. Find the following: Be sure to show the correct units for each value.

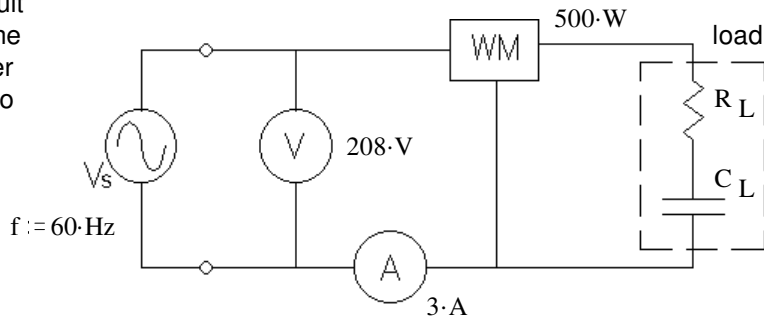

- a) The real power. $P = ?$
- b) The value of the load resistor. $R_L = ?$
- c) The apparent power. $|S| = ?$
- d) The reactive power. $Q = ?$
- e) The complex power. $\mathbf{S} = ?$
- f) The power factor. $pf = ?$
- g) The power factor is: i) leading ii) lagging
- h) The two components of the load are in a box which cannot be opened. Add (draw it) another component to the circuit above which can correct the power factor (make $pf = 1$). Show the correct component in the correct place and find its value. This component should not affect the real power consumption of the load.

6. (14 pts) The transformer shown in the circuit below is ideal. It is rated at 120/24 V, 30 VA, 60 Hz. Find the following:

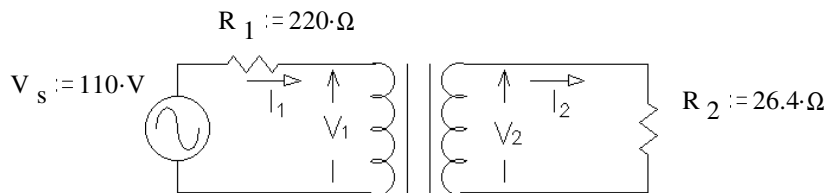

- a) $I_1 = ?$
- b) $V_2 = ?$

Problem 8 is out of order

8. (23 pts) In the circuit shown, use the constant-voltage-drop model for the silicon diode.

- a) Assume that diode D_1 does conduct. Assume that diode D_2 does NOT conduct. Find I_{R1} , I_{R2} , I_{R3} , I_{V2} , & based on these assumptions. Stick with these assumptions even if your answers come out absurd. Hint: think in nodal voltages.

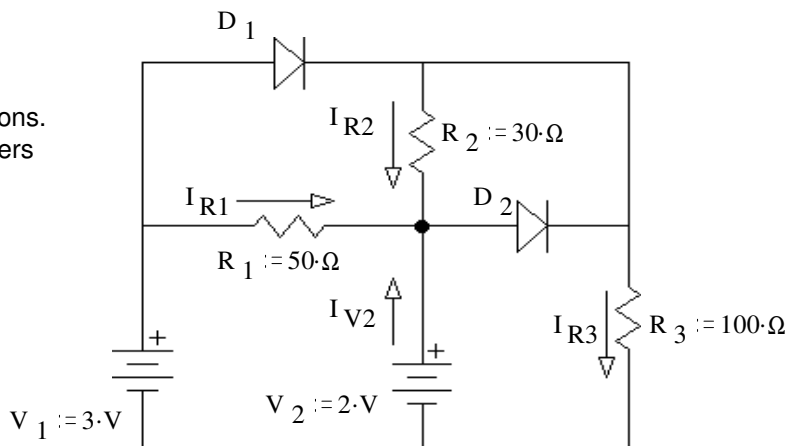

- $I_{R1} = \underline{\hspace{2cm}}$
- $I_{R2} = \underline{\hspace{2cm}}$
- $I_{R3} = \underline{\hspace{2cm}}$
- $I_{V2} = \underline{\hspace{2cm}}$

b) Based on your numbers, does it look like the assumption about D_1 (conducting) was correct? yes no
(circle one)

How do you know? (Specifically show a value which is or is not within a correct range.)

c) Based on your numbers, does it look like the assumption about D_2 (not conducting) was correct? yes no
(circle one)

How do you know? (Specifically show a value which is or is not within a correct range.)

ECE1050 Final given: Spring 04 p3

7. (34 pts) The same input signal (at right) is connected to several op-amp circuits below. Sketch the output waveform for each circuit. Clearly label important voltage levels on each output. If I can't easily make out what your peak values are, I'll assume you don't know. Don't forget to show inversions. All op-amps are powered by $\pm 15\text{ V}$ power supplies.

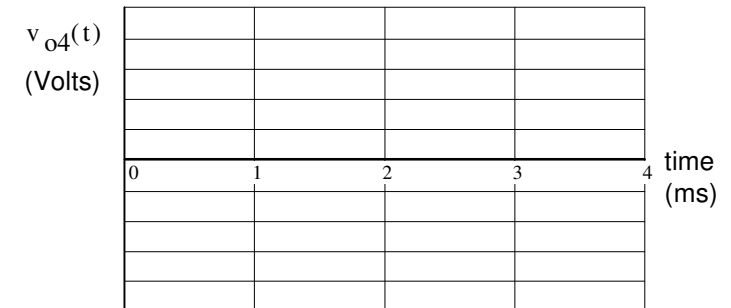
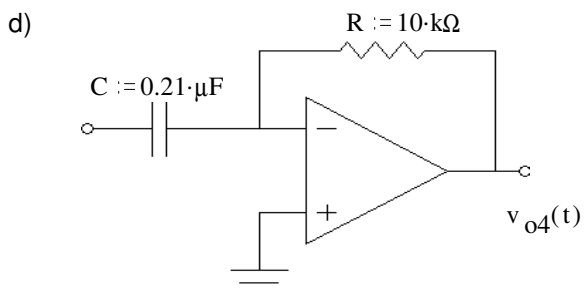
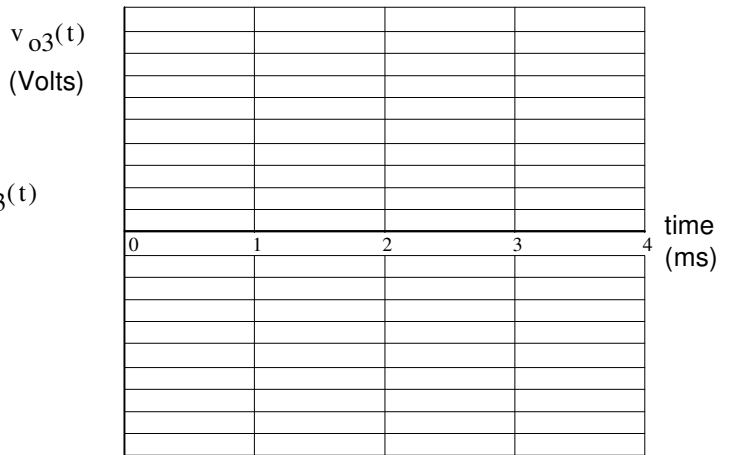
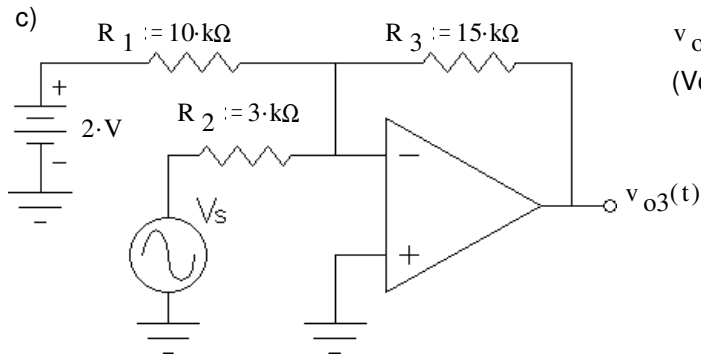
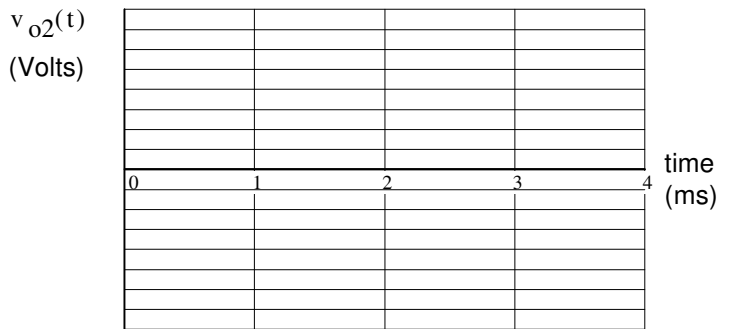
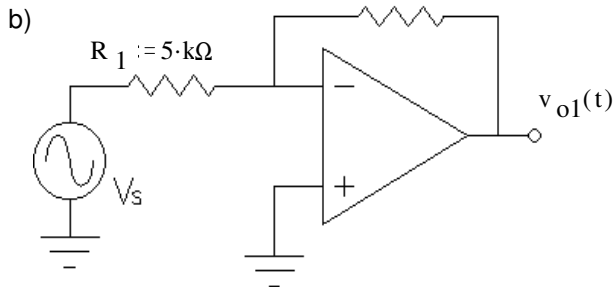
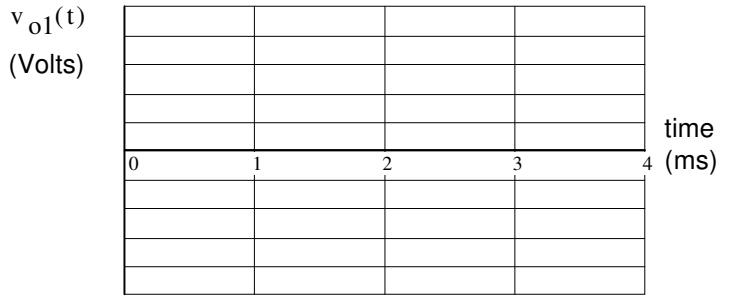
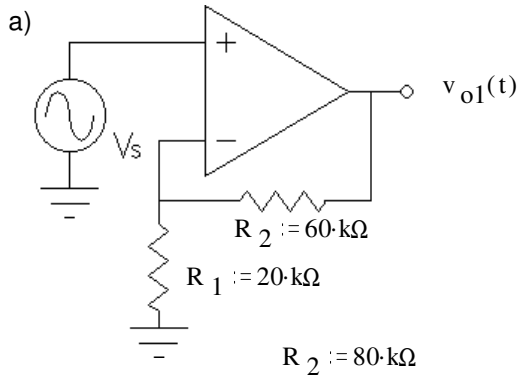
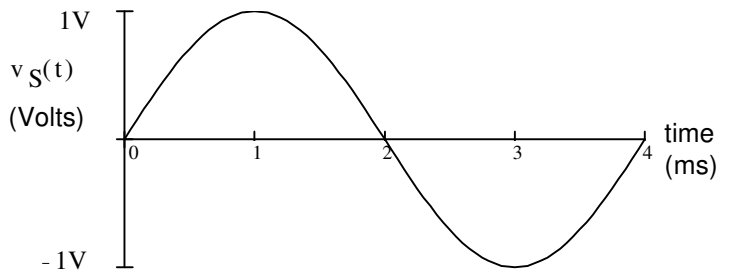

ECE1050 Final given: Spring 04 p4

9. Do you want your grade and scores posted on my door and on the internet? Yes No (Circle one)

If your answer is yes, then provide some sort of alias or password: _____

The grades will be posted on my door in alphabetical order under the alias that you provide here. I will not post grades under your real name. The internet version will be a pdf file or an excel spreadsheet which you can download. Both will show all your homework, lab, and exam scores.

Answers

1. a) $12 \cdot V - 10 \cdot V \cdot e^{-\frac{t}{60 \text{ms}}}$ b) $5.93 \cdot V$ c) $2 \cdot V + 3.93 \cdot V \cdot e^{-\frac{t'}{10 \text{ms}}}$

2. a) $I_{in} = 26.8 \angle -26.6^\circ \text{ mA}$ b) $V_T = 6.63 \angle -42^\circ \text{ V}$ c) i

3. a) $184 \cdot \text{mA}$ $2.48 \cdot \text{V}$ $0.456 \cdot \text{W}$ yes $V_{CE} = 2.5 \cdot \text{V} > 0.2 \cdot \text{V}$ b) $354 \cdot \Omega$ c) 56.5

4. a) $4.67 \cdot \text{V}$ b) $6.22 \cdot \text{V}$

5. a) $500 \cdot \text{W}$ b) $55.6 \cdot \Omega$ c) $624 \cdot \text{VA}$ d) $-373 \cdot \text{VAR}$ e) $(500 - 373j) \cdot \text{VA}$

f) 0.801 g) i h) $307 \cdot \text{mH}$ Inductor in parallel with load

6. a) $125 \cdot \text{mA}$ b) $16.5 \cdot \text{V}$

8. answer below

7. a) $v_{o1}(t)$ (Volts)

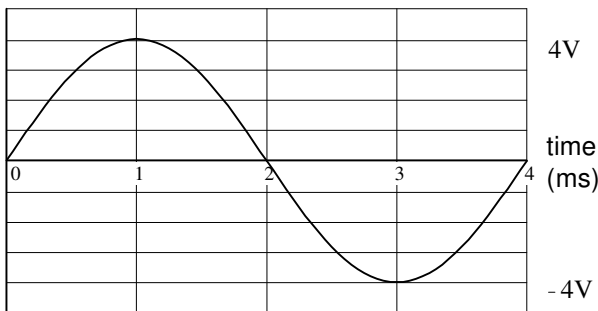

b) $v_{o2}(t)$ (Volts)

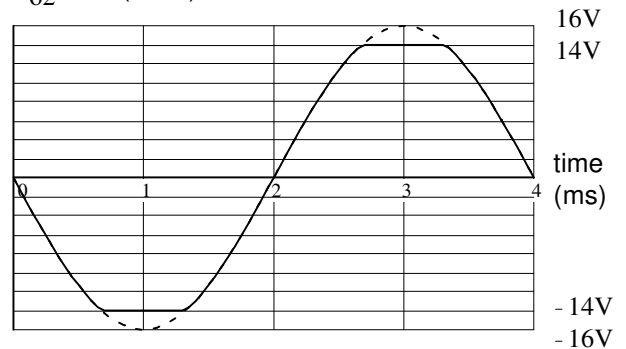

c) $v_{o3}(t)$ (Volts)

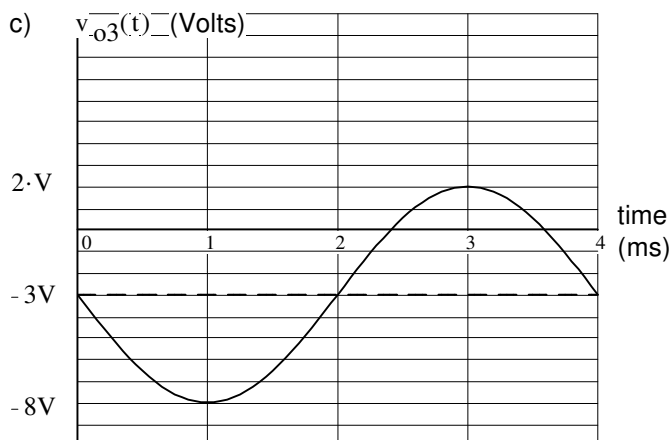

d) $v_{o4}(t)$ (Volts)

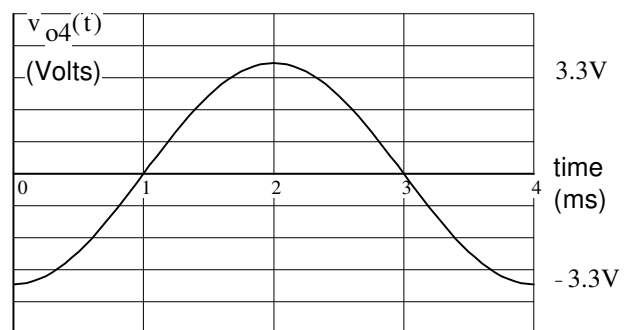

ECE 1050 Final

Name _____

Scores:

page 1-2 _____ / 43 pts

page 3-4 _____ / 42 pts

page 5-6 _____ / 38 pts

page 7-8 _____ / 34 pts

page 9 _____ / 23 pts

8. a) $20 \cdot \text{mA}$ $10 \cdot \text{mA}$ $23 \cdot \text{mA}$ $-30 \cdot \text{mA}$

b) yes $I_{D1} = 33 \cdot \text{mA} > 0$

c) yes $V_{D1} = -V_{R2} = -0.3 \cdot \text{V} < 0.7 \text{V}$