

ECE2210 Final given: Fall 05

1. (14 pts) The switch has been open (not making contact) for a long time and is switched closed (as shown) at time $t = 0$.

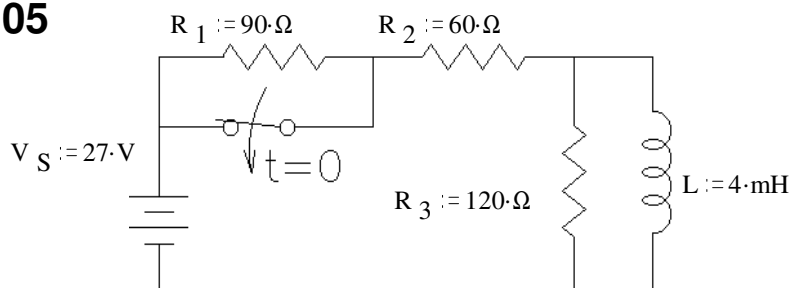

Find the complete expression for $i_L(t)$.

2. (15 pts) For partial credit, you must show work and/or intermediate results.

- Find I_2
- Find V_S
- Find I_1 in polar form.

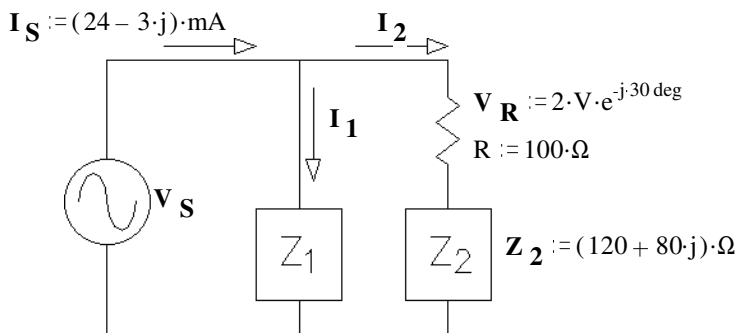

3. (30 pts) a) Draw the asymptotic Bode plot (the straight-line approximation) of the filter circuit below. Accurately draw it on the graph provided. V_{in} is the input and V_o is the output of this circuit. Graph is in rad/sec. You must show the steps you use to get the Bode plot. That is, show things like the corner frequency(ies), the approximations of the transfer function in each frequency region, calculations of dB, etc..

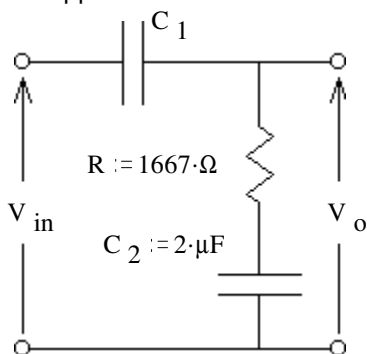

I've found the transfer function:
$$H(\omega) = \frac{1 + j\omega R C_2}{5 + j\omega R C_2}$$

Draw the straight-line Bode plot

Magnitude plot dB
 $|H(\omega)|$

Straight-line approximation _____
Actual - - - -

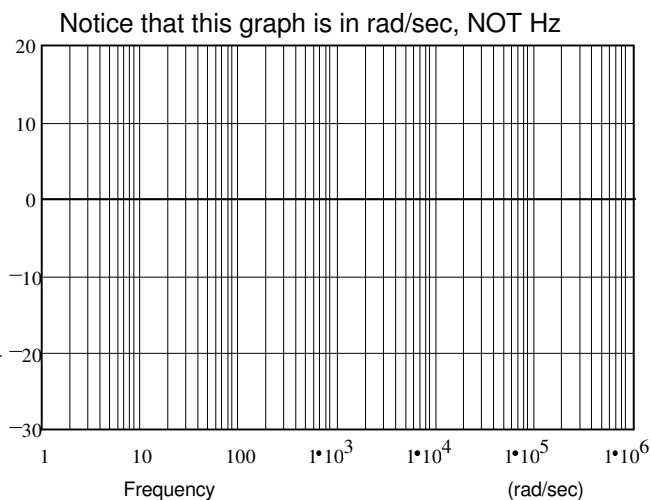

- The asymptotic Bode plot is not exact. The actual magnitude of the transfer function can be a little different than the straight-line approximation. Draw in the actual frequency response curve with a dashed line. For the frequency(ies) where the curves are most different, indicate the actual dB on the plot.
- If there are any corners in the Bode plot associated with **poles** in the transfer function, list that/those corner frequency(ies) below (ω_p).
- If there are any corners in the Bode plot associated with **zeroes** in the transfer function, list that/those corner frequency(ies) below (ω_z).
- What is the value of C_1 ?

Hint: Find the Transfer function in terms of C_1 , C_2 , R , & ω and compare what you get to my transfer function.

4. (13 pts) a) Find the s-type transfer function of the circuit shown.
 V_i is the input and V_o is the output.
 You **MUST** show work to get credit.
 Simplify your expression for $H(s)$ so that the denominator is a simple polynomial.

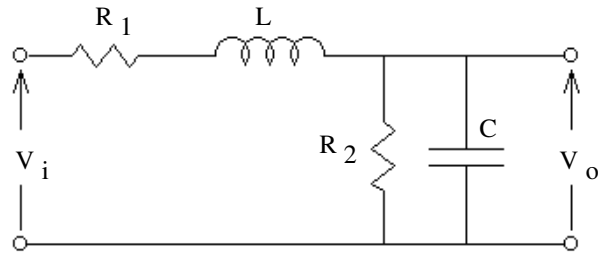

$H(s) = ?$

- b) Find the characteristic equation of the circuit shown.

5. (18 pts) Consider the circuit at right. The current source has been 50 mA for a long time and changes from 50 mA to 20 mA at time $t = 0$.

- a) What are the final conditions of i_L and the v_C ?

$i_L(\infty) = ? \quad v_C(\infty) = ?$

- b) Find the initial condition and initial slope of i_L that you would need to have in order to find all the constants in $i_L(t)$. Don't find $i_L(t)$ or it's constants, just the initial conditions.

$t < 0 : I_S := 50 \text{ mA}$

$t \geq 0 : I_S := 20 \text{ mA}$

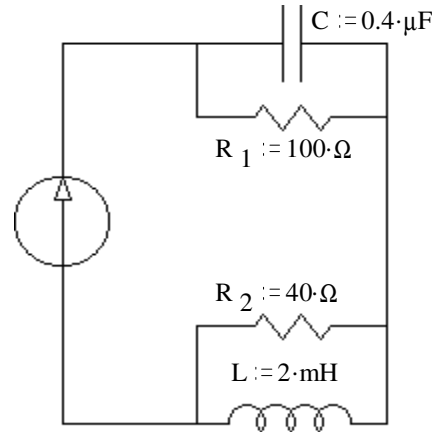

- c) Find the initial condition and initial slope of v_C that you would need to have in order to find all the constants in $v_C(t)$. Don't find $v_C(t)$ or it's constants, just the initial conditions.

Use constant-voltage-drop models for the diodes and LEDs on this exam.

6. (18 pts) Assume that diode D_1 does NOT conduct. Assume that diode D_2 does conduct.

- a) Find I_{R1} , I_{R2} , I_{R3} , & I_{V2} based on these assumptions. Stick with these assumptions even if your answers come out absurd

$I_{R1} = \underline{\hspace{2cm}} \quad I_{R3} = \underline{\hspace{2cm}}$

$I_{R2} = \underline{\hspace{2cm}} \quad I_{D2} = \underline{\hspace{2cm}}$

- b) Was the assumption about D_1 correct? (circle one)
 yes no

How do you know? (Specifically show a value which is or is not within a correct range.)

- c) Was the assumption about D_2 correct? (circle one)
 yes no

How do you know?

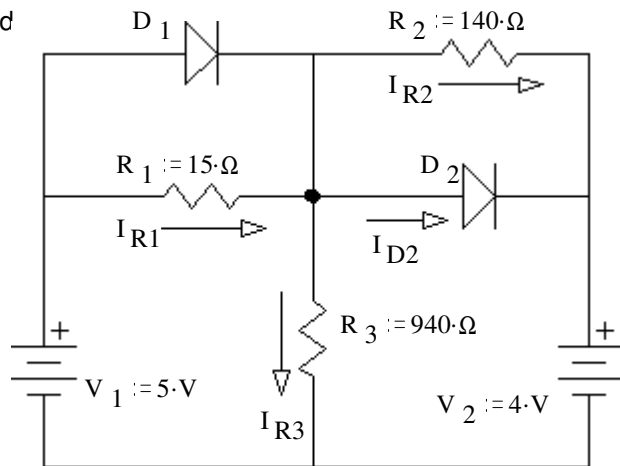

7. (18 pts) A voltage waveform (dotted line) is applied to the circuit shown. Accurately draw the output waveform (v_o) you expect to see. Label important times **and** voltage levels.

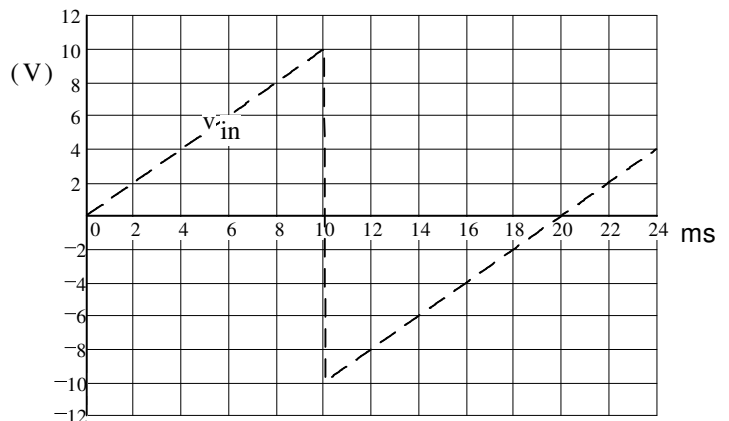
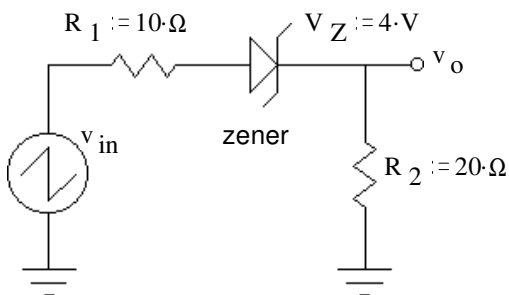

ECE2210 Final given: Fall 05 p3

8. (27 pts) The same input signal (at right) is connected to several op-amp circuits below. Sketch the output waveform for each circuit. Clearly label important voltage levels on each output. If I can't easily make out what your peak values are, I'll assume you don't know. Don't forget to show inversions. All op-amps are powered by $\pm 15\text{ V}$ power supplies.

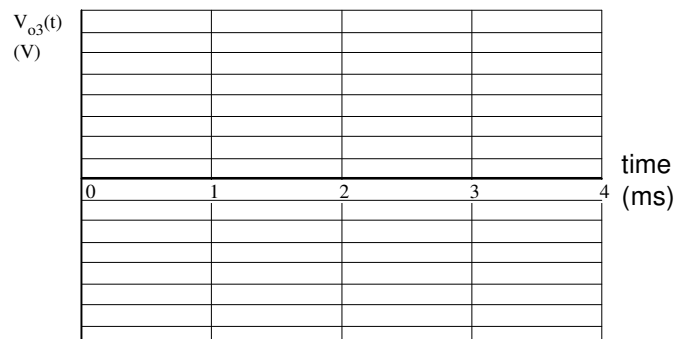
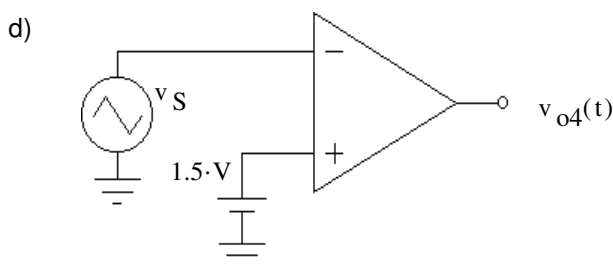
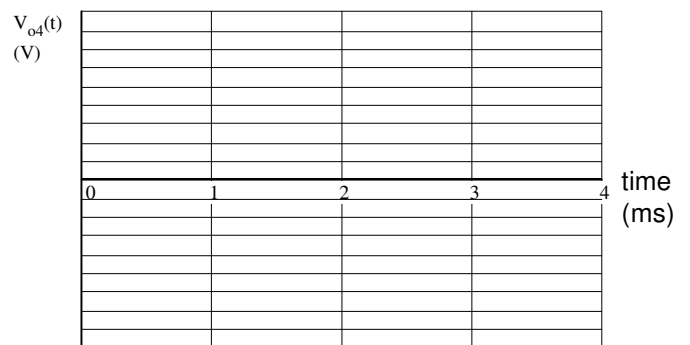
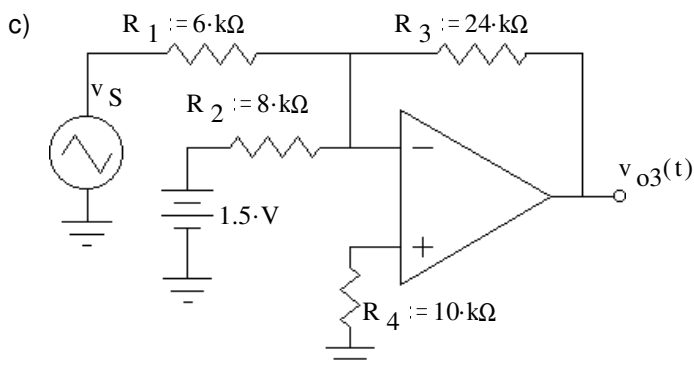
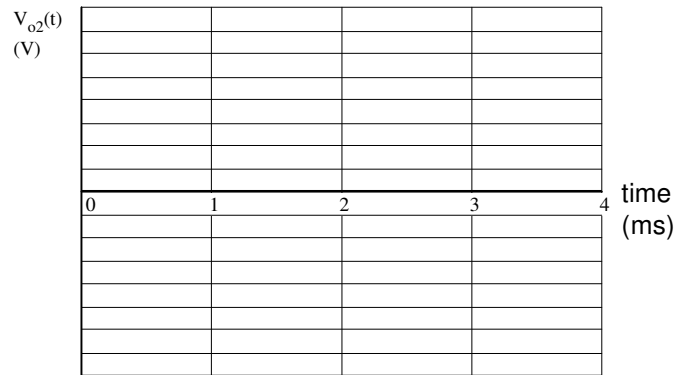
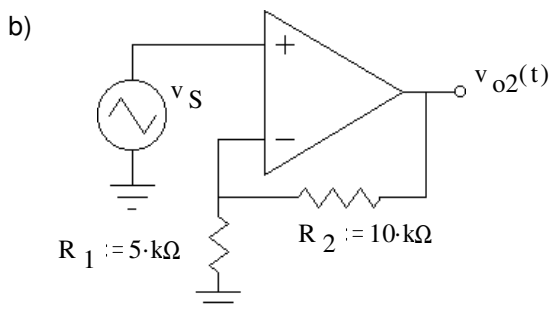
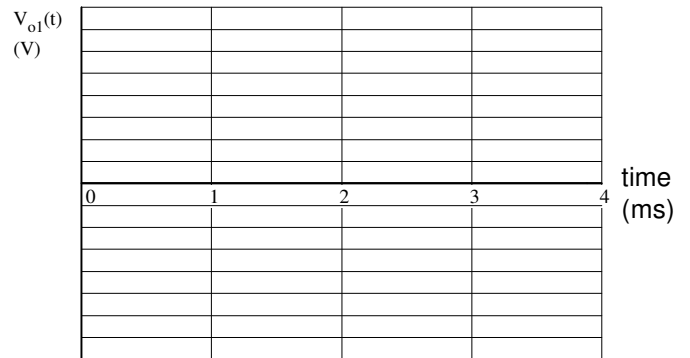
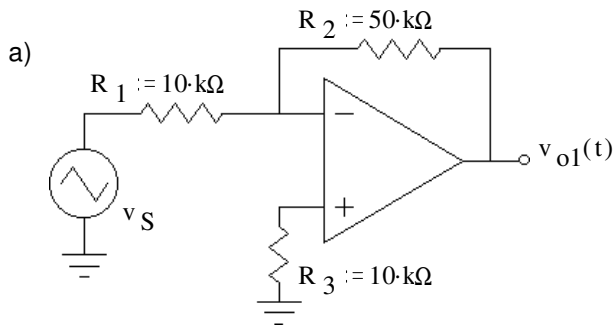
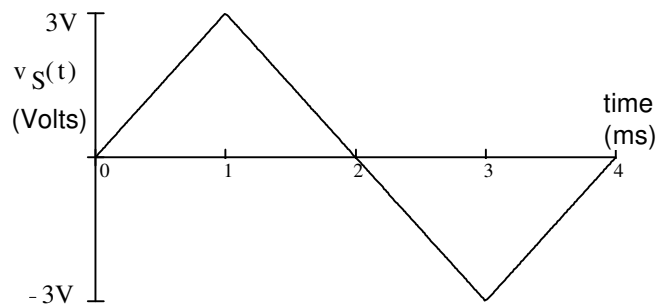

ECE2210 Final given: Fall 05 p4

9. (27 pts) a) $\beta := 25$ Assume the transistor is in the active region, find I_{sw} , I_L , V_L , V_{EC} and P_Q .

- $I_{sw} = ?$
- $I_L = ?$
- $V_L = ?$
- $V_{EC} = ?$
- $P_Q = ?$

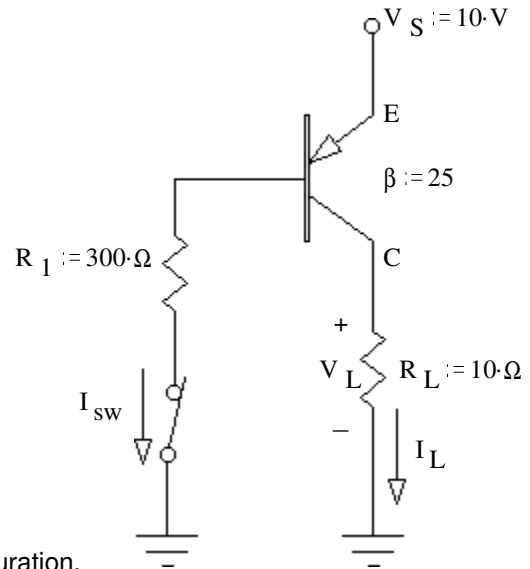

b) Was the transistor actually operating in the active region?
 yes no (circle one)

How do you know? (Specifically show a value which is or is not within a correct range.)

- c) Find the maximum value of R_1 , so that the transistor will be in saturation.
- d) $R_1 = 300 \cdot \Omega$ and can't be changed, find the minimum value of β so that the transistor will be in saturation.
- e) How much power is dissipated by the transistor in d)
- f) The switch is opened. What is the load current (I_L) now?

10. Do you want your grade and scores posted on my door and on the internet? Yes No (Circle one)

If your answer is yes, then provide some sort of alias or password: _____

The grades will be posted on my door in alphabetical order under the alias that you provide here. I will not post grades under your real name. The internet version will be a pdf file which you can download. Both will show the homework, lab, and exam scores of everyone who answers yes here.

Answers

1. $450 \cdot \text{mA} - 270 \cdot \text{mA} \cdot e^{-\frac{t}{0.1 \cdot \text{ms}}}$

2. a) $I_2 := 20 \cdot \text{mA} \cdot e^{-j30 \text{ deg}}$
 b) $V_S = (4.61 + 0.814 \cdot j) \cdot \text{V}$
 $= 4.68 \cdot \text{V} \cdot e^{-j10 \text{ deg}}$

c) $I_1 = 9.68 \cdot \text{mA} \cdot e^{j46.3 \text{ deg}}$

3. a) & b)

Magnitude plot dB

$|H(\omega)|$

Straight-line approximation _____

Actual - - - - -

c) $1500 \cdot \frac{\text{rad}}{\text{sec}}$

d) $300 \cdot \frac{\text{rad}}{\text{sec}}$

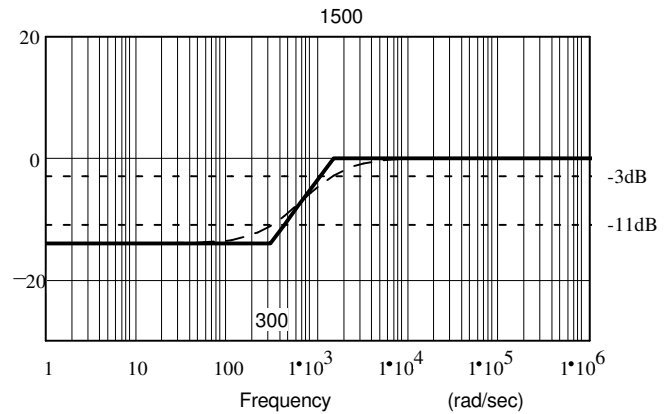

e) $0.5 \cdot \mu\text{f}$

4. a) $H(s) = \frac{1}{L \cdot C} \cdot \frac{1}{s^2 + \left(\frac{R_1}{L} + \frac{1}{R_2 \cdot C}\right) \cdot s + \left(1 + \frac{R_1}{R_2}\right) \cdot \frac{1}{L \cdot C}}$

b) $0 = s^2 + \left(\frac{R_1}{L} + \frac{1}{R_2 \cdot C}\right) \cdot s + \left(1 + \frac{R_1}{R_2}\right) \cdot \frac{1}{L \cdot C}$

5. a) $2 \cdot \text{V}$ $20 \cdot \text{mA}$ b) $50 \cdot \text{mA}$ $-600 \cdot \frac{\text{A}}{\text{sec}}$ c) $5 \cdot \text{V}$ $-75000 \cdot \frac{\text{V}}{\text{sec}}$

6. a) 20mA 5mA 5mA 10mA b) yes, $V_{D1} = 0.3 \text{V} < 0.7 \text{V}$ c) yes, $I_{D2} = 10 \text{mA} > 0$

ECE2210 Final given: Fall 05 p4

ECE2210 Final given: Fall 05 p5

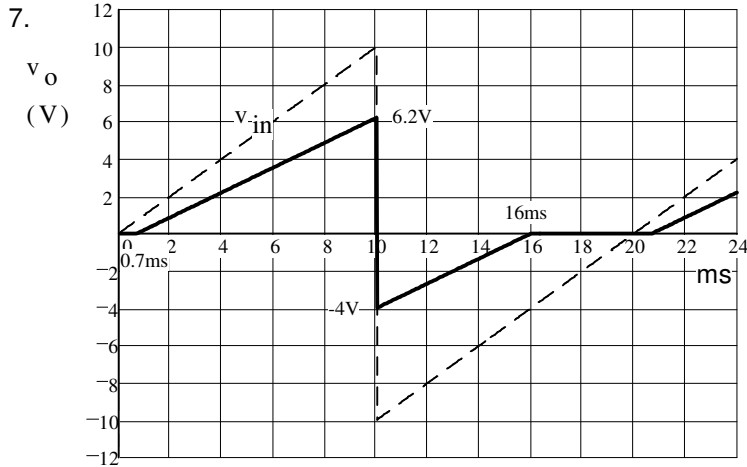

9. a) 31mA 775mA 7.75V 2.25V 1.744W
 b) yes, $V_{EC} = 2.25V > 0.2V$ c) 237Ω
 d) 31.6 e) 0.196W f) 0

8.
 $V_{o1}(t)$
 (V)

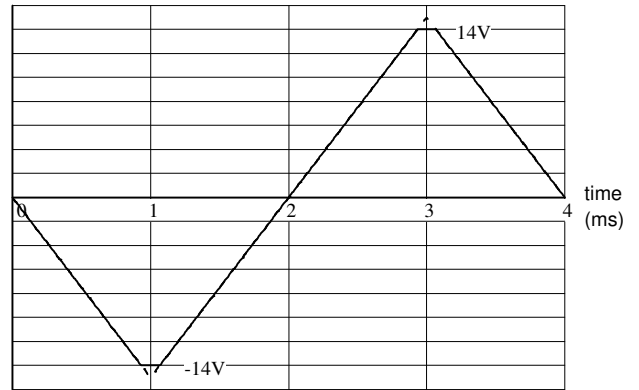

$V_{o2}(t)$
 (V)

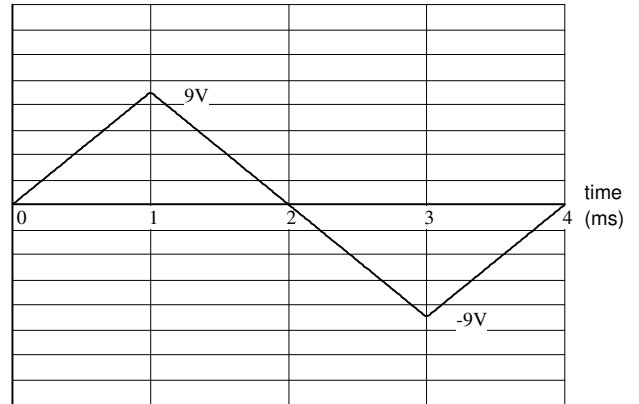

$V_{o3}(t)$
 (V)

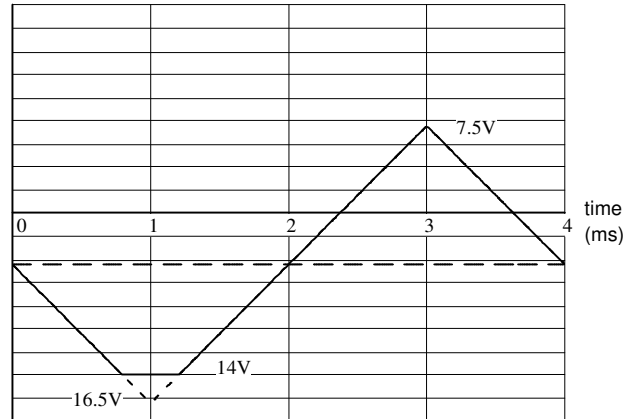

$V_{o4}(t)$
 (V)

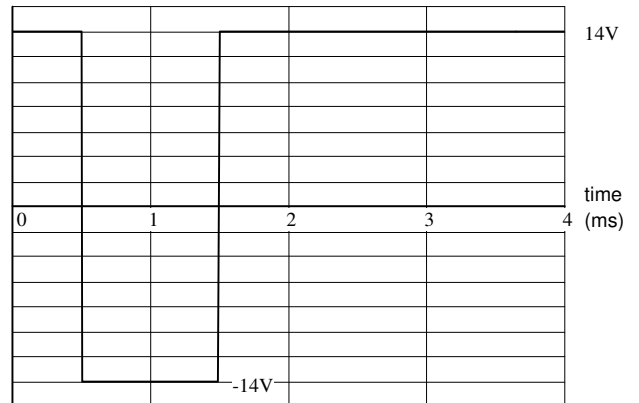

ECE 2210 Final

Name _____

Scores:

pages 1-2 _____ / 29 pts

pages 3-4 _____ / 30 pts

pages 5-6 _____ / 31 pts

pages 7-8 _____ / 36 pts

pgs 9-10 _____ / 27 pts

pgs 11-12 _____ / 27 pts

Total _____ / 180 pts