

# ECE2210/00 Exam 3 given: Spring 07

(The space between problems has been removed.)

1. (16 pts) A frequency response curve is shown below (dashed line).

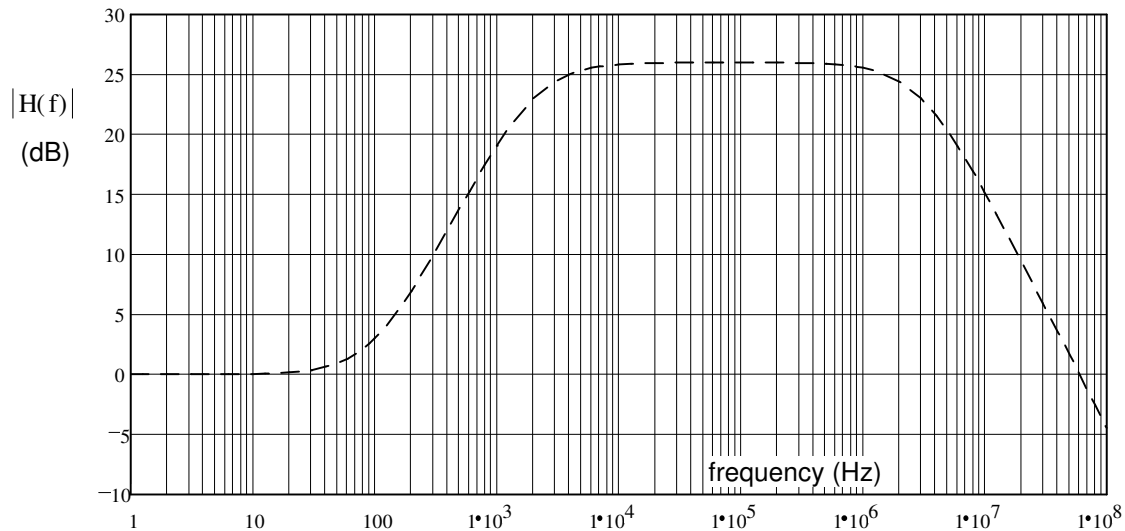

a) Draw the Bode plot of  $H(s)$  (the straight-line approximation) right on the curve above.

b) List any and all corner frequencies that you can find from the graph above.

c) If there are any corners in the Bode plot associated with **poles** in the transfer function, list that/those corner frequency(ies) below ( $f_p$ ).

d) If there are any corners in the Bode plot associated with **zeros** in the transfer function, list that/those corner frequency(ies) below ( $f_z$ ).

e) This Bode plot is for what type of filter? Circle the best answer.

- i) low pass    ii) high pass    iii) band pass    iv) band reject    v) sludge    vi) coffee    vii) can't tell

2. (20 pts) Analysis of a circuit (not pictured) yields the characteristic equation below.

$$0 = s^2 + 160 \cdot s + 1006400$$

$$R := 80 \cdot \Omega$$

$$L := 0.2 \cdot \text{mH}$$

$$C := 25 \cdot \mu\text{F}$$

Further analysis yields the following initial and final conditions:

$$i_L(0) = 10 \cdot \text{mA}$$

$$v_L(0) = -6 \cdot \text{V}$$

$$v_C(0) = 4 \cdot \text{V}$$

$$i_C(0) = -40 \cdot \text{mA}$$

$$i_L(\infty) = 50 \cdot \text{mA}$$

$$v_L(\infty) = 0 \cdot \text{V}$$

$$v_C(\infty) = 12 \cdot \text{V}$$

$$i_C(\infty) = 0 \cdot \text{mA}$$

Write the full expression for  $v_C(t)$ , including all the constants that you find.

$$v_C(t) = ?$$

3. (20 pts) The switch has been open for a long time and is closed (as shown) at time  $t = 0$ .

a) What are the final conditions of  $i_L$  and the  $v_C$ ?

$$i_L(\infty) = ? \quad v_C(\infty) = ?$$

b) Find the initial condition and initial slope of  $i_L$  that you would need to have in order to find all the constants in  $i_L(t)$ . Don't find  $i_L(t)$  or it's constants, just the initial conditions.

c) Find the initial condition and initial slope of  $v_C$  that you would need to have in order to find all the constants in  $v_C(t)$ . Don't find  $v_C(t)$  or it's constants, just the initial conditions.

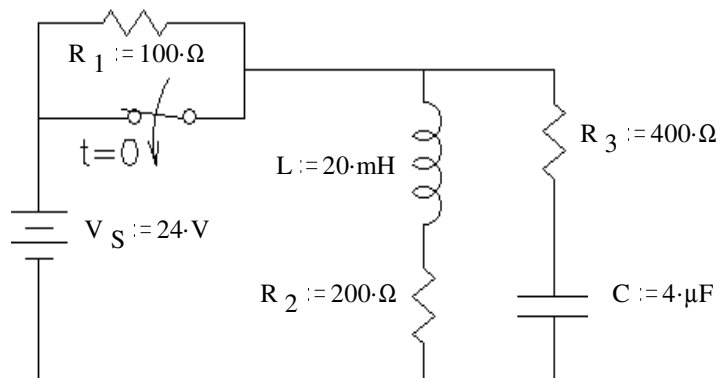

**ECE2210/00 Exam 3 Spring 07 p1**

4. (20 pts) a) A feedback system is shown in the figure. What is the transfer function of the whole system, with feedback.

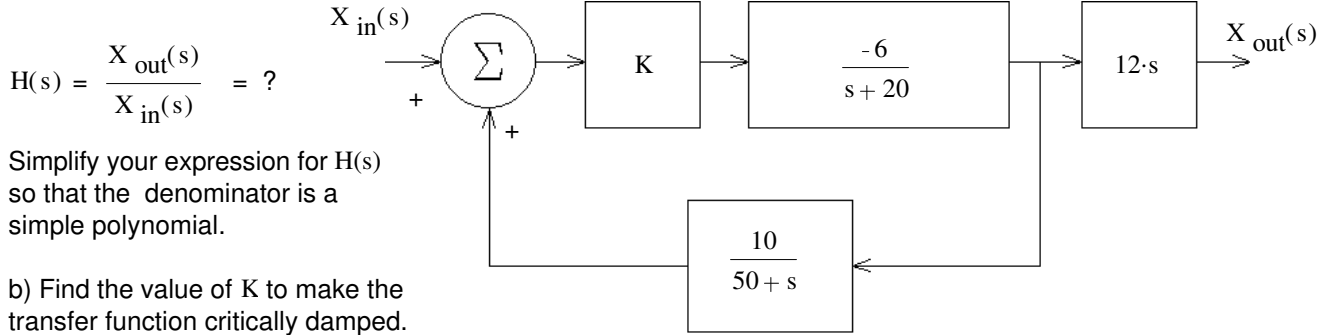

Simplify your expression for  $H(s)$  so that the denominator is a simple polynomial.

b) Find the value of  $K$  to make the transfer function critically damped.

c) If  $K$  is **less** than this value the system will be: underdamped or overdamped Circle one

d) Does the transfer function have a zero? Answer no or find the  $s$  value(s) of the zero(s).

5. (20 pts)  $R$ ,  $L$ , &  $C$  together are the load in the circuit shown. Find the following: Be sure to show the correct units for each value.

- a) The real power.  $P = ?$
- b) The reactive power.  $Q = ?$
- c) The complex power.  $S = ?$
- d) The apparent power.  $|S| = ?$
- e) The power factor.  $pf = ?$
- f) The power factor is:
  - i) leading ii) lagging (circle one)

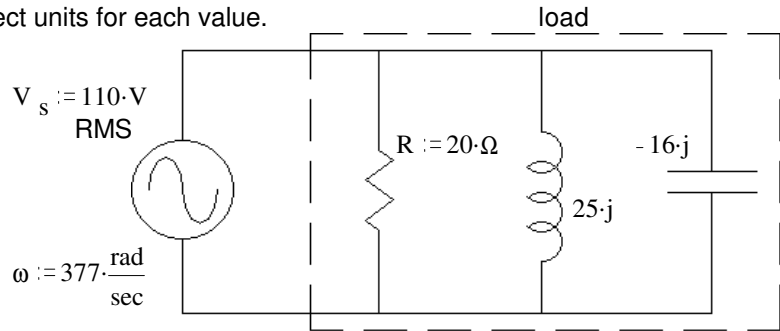

g) The three components of the load are in a box which cannot be opened. Add (draw it) another component to the circuit above which can correct the power factor (make  $pf = 1$ ). Show the correct component in the correct place and find its value. This component should not affect the real power consumption of the load.

- 6. (4 pts) Find:
  - a) The average, DC ( $V_{DC}$ ) voltage.
  - b) The RMS (effective) voltage

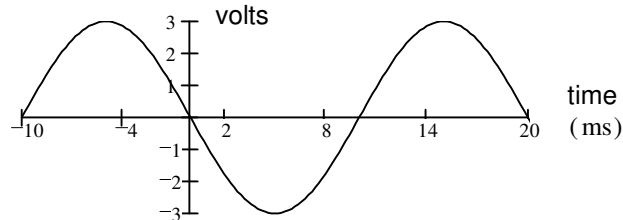

**Answers**

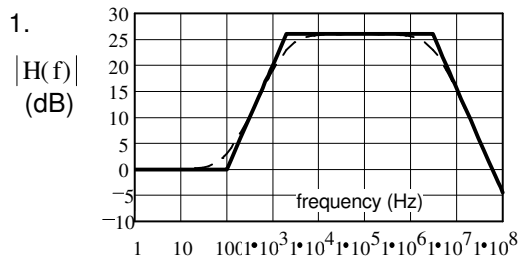

- b) 100-Hz 2-kHz 3-MHz c) 2-kHz 3-MHz d) 100-Hz (70 - 100Hz accepted, 2kHz & 3MHz can also be a little off)
- e) iii) band pass

2.  $v_C(t) := 12 \cdot V + e^{-\frac{80}{sec} \cdot t} \cdot \left( -8 \cdot V \cdot \cos\left(\frac{1000}{sec} \cdot t\right) - 2.24 \cdot V \cdot \sin\left(\frac{1000}{sec} \cdot t\right) \right)$

- 3. a) 120-mA 24-V b) 80-mA  $400 \cdot \frac{A}{sec}$  c) 16-V  $5000 \cdot \frac{V}{sec}$

4. a)  $12 \cdot s \cdot \frac{-6 \cdot K \cdot (s + 50)}{s^2 + 70 \cdot s + 60 \cdot K + 1000}$  b) 3.75 c) overdamped d) -50, 0

- 5. a) 605-W b) -272-VAR c)  $(605 - 272 \cdot j) \cdot VAR$  d) 663-VAR e) .912 f) i) leading g) 118-mH
- 6. a) 0-V b) 2.12-V