

ECE 2210 Exam 3 given: Fall 14

(The space between problems has been removed.)

1. (24 pts) a) Draw the asymptotic Bode plot (the straight-line approximation) of the transfer function below. Accurately draw it on the graph provided.

You must show the steps you use to get the Bode plot. That is, show things like the corner frequency(ies), the approximations of the transfer function in each frequency region, calculations of dB, etc..

$$H(f) := \frac{120000 \cdot j \cdot f}{\left(1 + \frac{0.05}{\text{Hz}} \cdot j \cdot f\right) \cdot (30000 \cdot \text{Hz} + j \cdot f)}$$

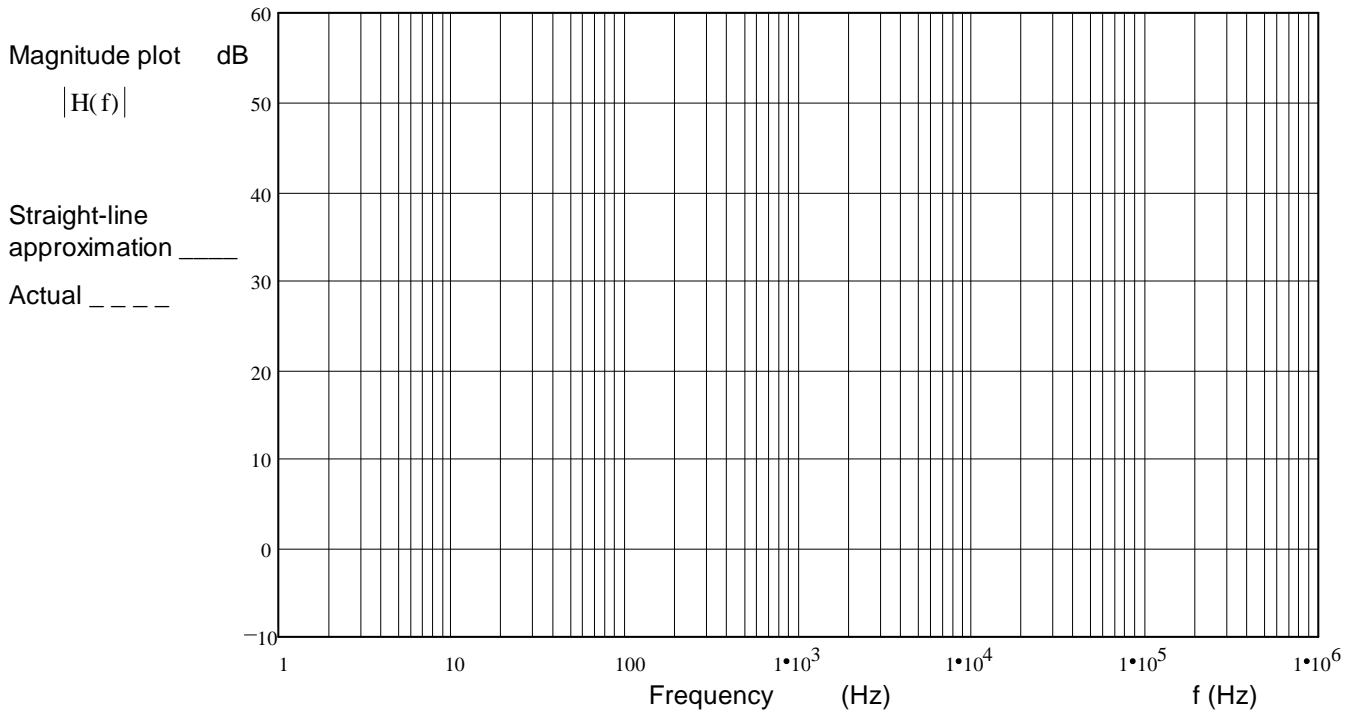

- b) The asymptotic Bode plot is not exact. Using a dotted line, sketch the actual magnitude of the transfer function $|H(f)|$ on the plot above. Indicate the point(s) where the difference between the two lines is the biggest (draw arrow(s)) and write down the actual magnitude(s) at that (those) point(s).
- c) If there are any corners in the Bode plot associated with **poles** in the transfer function, list that/those corner frequency(ies) here (f_p).
- d) If there are any corners in the Bode plot associated with **zeroes** in the transfer function, list that/those corner frequency(ies) here (f_z).

2. (20 pts) a) A feedback system is shown in the figure. What is the transfer function of the whole system, with feedback.

$$H(s) = \frac{X_{\text{out}}(s)}{X_{\text{in}}(s)} = ?$$

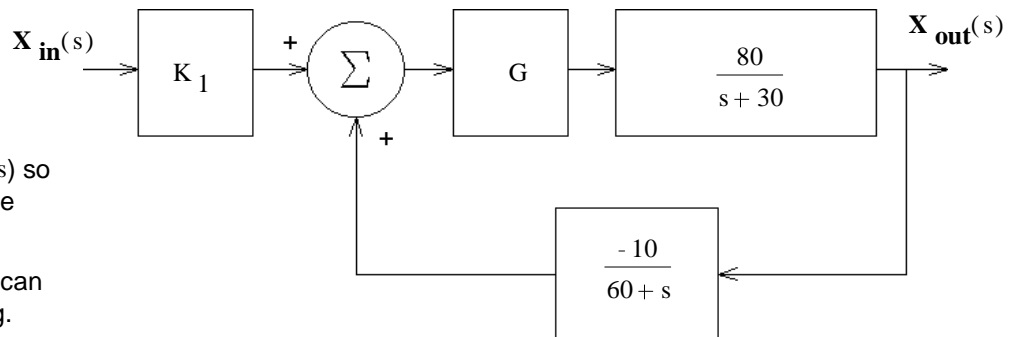

Simplify your expression for $H(s)$ so that the denominator is a simple polynomial in standard form.

Be clear about your signs, so I can tell you know what you're doing.

- b) Find the value of G to make the transfer function critically damped.
- c) If G is **less** than this value the system will be: underdamped or overdamped Circle one
- d) Does the transfer function have a zero? Answer "no" or find the s value(s) of the zero(s).

ECE 2210 Exam 3 Fall 14 p2

3. (31 pts) The switch has been open for a long time and is closed (as shown) at time $t = 0$.

SHOW YOUR WORK, no credit for guesses!

- a) What are the final conditions of i_L and the v_C ?
 $i_L(\infty) = ? \quad v_C(\infty) = ?$
- b) Find the initial condition and initial slope of i_L that you would need to have in order to find all the constants in $i_L(t)$. Don't find $i_L(t)$ or it's constants, just the initial conditions.
- c) Find the initial condition and initial slope of v_C that you would need to have in order to find all the constants in $v_C(t)$. Don't find $v_C(t)$ or it's constants, just the initial conditions.

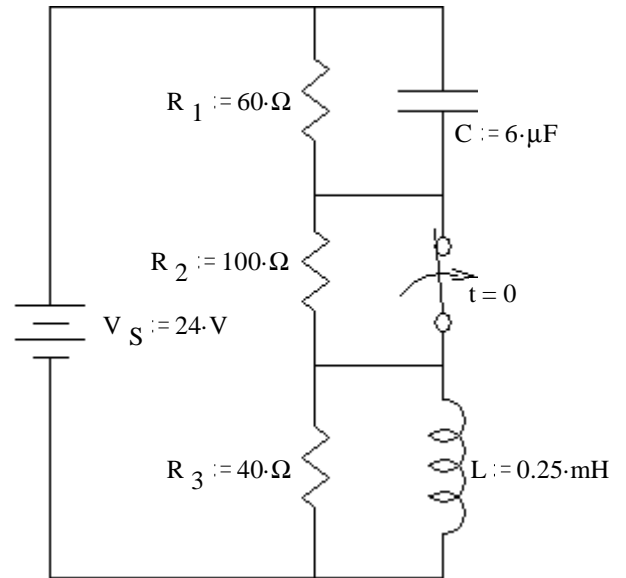

4. (25 pts) R, L, & C together are the load in the circuit shown. Find the following for the load (in dotted box): Be sure to show the correct units for each value.

- a) The real power. $P = ?$
- b) The reactive power. $Q = ?$
- c) The complex power. $S = ?$
- d) The apparent power. $|S| = ?$
- e) The power factor. $pf = ?$
- f) The power factor is: i) leading ii) lagging (circle one)
- g) The magnitudes of the three currents. $|I_S| = ? \quad |I_R| = ? \quad |I_C| = ?$
- h) Is there something weird about these currents? If so, what?

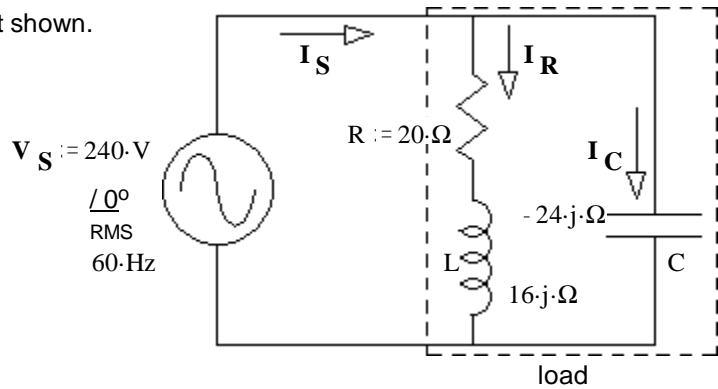

Answers

1. a), b)

- Magnitude plot $|H(f)|$ dB
- Straight-line approximation
- Actual
- c) 20-Hz
30-kHz
- d) none

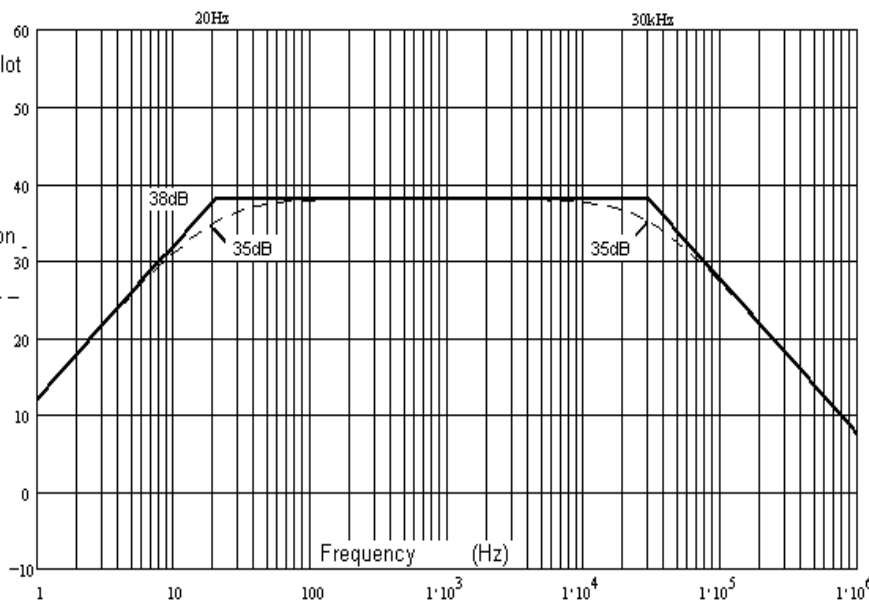

- 2. a) $K_1 \cdot \frac{G \cdot 80 \cdot s + G \cdot 4800}{s^2 + 90 \cdot s + 800 \cdot G + 1800}$
- b) 0.281 c) overdamped
- d) -60
- 3. a) 400-mA 24-V
- b) 150-mA $60000 \cdot \frac{A}{\text{sec}}$
- c) 9-V $62500 \cdot \frac{V}{\text{sec}}$
- 4. a) 1756-W b) -995-VAR
- c) $(1756 - 995 \cdot j) \cdot \text{VA}$
- d) 2018-VA e) 0.87
- f) Leading, capacitor dominates
- g) 8.41-A 9.37-A 10-A

h) $|I_S|$ is the smallest of the three because I_R and I_C are badly out of phase