

# ECE 2210/00 Exam 3 given: Fall 11

(The space between problems has been removed.)

1. (22 pts) a) Draw the asymptotic Bode plot (the straight-line approximation) of the transfer function below. Accurately draw it on the graph provided.

You must show the steps you use to get the Bode plot. That is, show things like the corner frequency(ies), the approximations of the transfer function in each frequency region, calculations of dB, etc..

$$H(f) := \frac{(200 \cdot \text{Hz} + 2 \cdot j \cdot f) \cdot \left(2 + \frac{j \cdot f}{20 \cdot \text{kHz}}\right)}{10 \cdot j \cdot f}$$

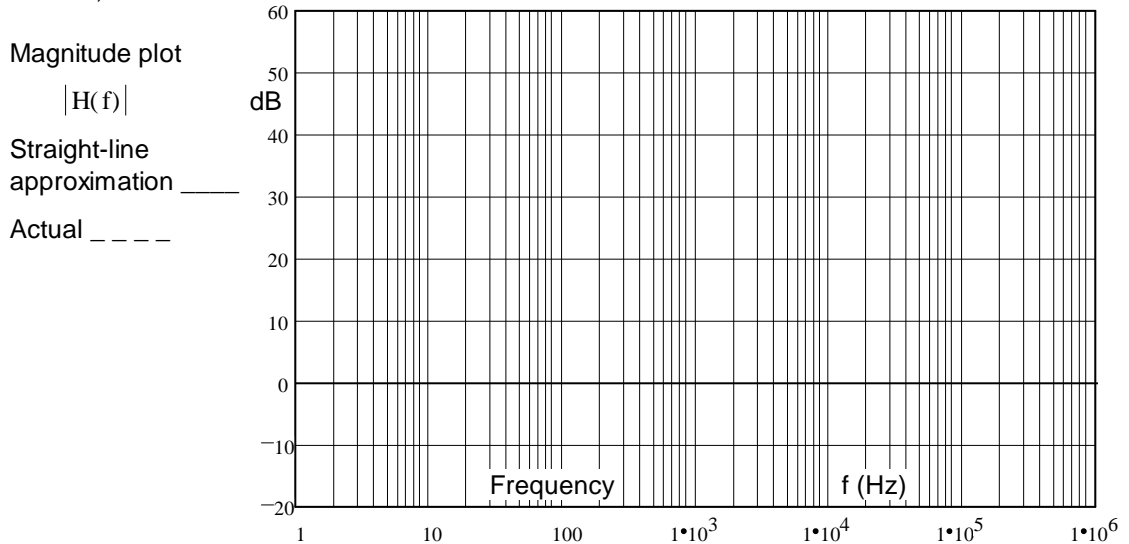

- b) The asymptotic Bode plot is not exact. Using a dotted line, sketch the actual magnitude of the transfer function  $|H(f)|$  on the plot above. Indicate the point(s) where the difference between the two lines is the biggest (draw arrow(s)) and write down the actual magnitude(s) at that (those) point(s).
- c) List any corners in the Bode plot associated with **zeroes** in the transfer function.
- d) List any corners in the Bode plot associated with **poles** in the transfer function.

2. (15 pts) For waveform shown, find:

a) Average DC ( $V_{DC}$ ) value

b) RMS (effective) value

c) The voltage is hooked to a circuit, as shown, for 12 seconds.

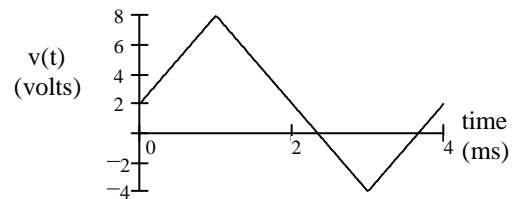
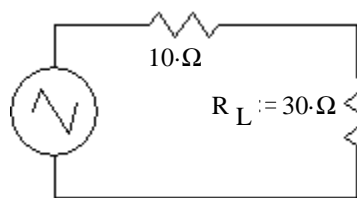

How much energy is transferred to  $R_L$  during that 12 seconds?

3. (18 pts) a) A feedback system is shown in the figure. What is the transfer function of the whole system, with feedback.

$$H(s) = \frac{X_{out}(s)}{X_{in}(s)} = ?$$

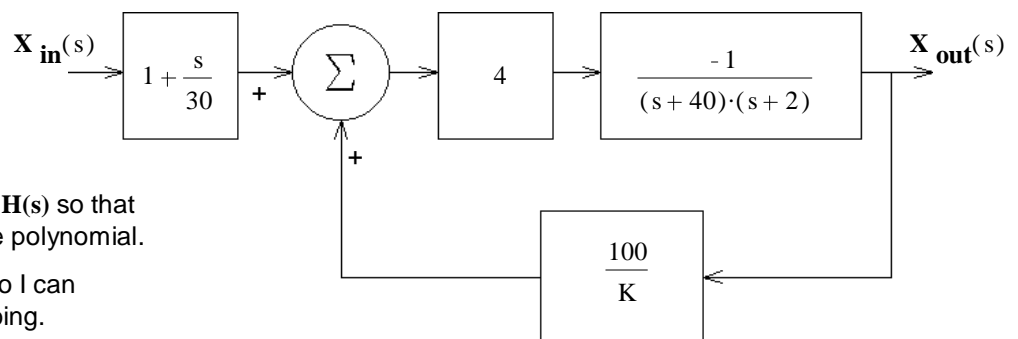

SHOW YOUR WORK

Simplify your expression for  $H(s)$  so that the denominator is a simple polynomial.

Be clear about your signs, so I can tell you know what you're doing.

- b) Find the value of  $K$  to make the transfer function critically damped.
- c) If  $K$  is **Greater** than this value the system will be: underdamped or overdamped Circle one
- d) Does the transfer function have a zero?  
Answer no or find the  $s$  value of that zero.

4. (15 pts) Analysis of a circuit (not pictured) yields the characteristic equation and solutions below.

$$0 = s^2 + 160 \cdot s + 166400 \quad s_1 := (-80 + 400 \cdot j) \cdot \frac{1}{\text{sec}} \quad \text{and} \quad s_2 := (-80 - 400 \cdot j) \cdot \frac{1}{\text{sec}}$$

$$L := 30 \cdot \text{mH} \quad R := 60 \cdot \Omega \quad C := 200 \cdot \mu\text{F}$$

Further analysis yields the following initial and final conditions:

$$i_L(0) = 15 \cdot \text{mA} \quad v_L(0) = -5 \cdot \text{V} \quad v_C(0) = -6 \cdot \text{V} \quad i_C(0) = 80 \cdot \text{mA}$$

$$i_L(\infty) = 50 \cdot \text{mA} \quad v_L(\infty) = 0 \cdot \text{V} \quad v_C(\infty) = 9 \cdot \text{V} \quad i_C(\infty) = 0 \cdot \text{mA}$$

Write the full expression for  $v_C(t)$ , including all the constants that you find.  $v_C(t) = ?$  Include **units** in your answer

5. (30 pts) The switch has been closed for a long time and is opened (as shown) at time  $t = 0$ .

SHOW YOUR WORK, no credit for guesses!

a) What are the final conditions of  $i_L$  and the  $v_C$ ?

$$i_L(\infty) = ? \quad v_C(\infty) = ?$$

b) Find the initial condition and initial slope of  $i_L$  that you would need to have in order to find all the constants in  $i_L(t)$ . Don't find  $i_L(t)$  or it's constants, just the initial conditions.

c) Find the initial condition and initial slope of  $v_C$  that you would need to have in order to find all the constants in  $v_C(t)$ . Don't find  $v_C(t)$  or it's constants, just the initial conditions.

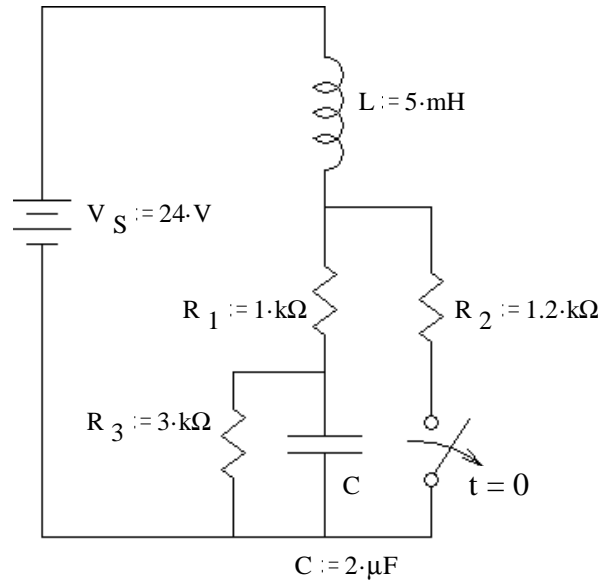

**Answers**

1. a & b)

c) 100-Hz 40-kHz d) none

2. a) 2·V b) 4·V c) 3.6·J

3. a) 
$$\frac{-\frac{4}{30} \cdot (s + 30)}{s^2 + 42 \cdot s + 80 + \frac{400}{K}}$$

b) 1.11 c) overdamped

d)  $s = -30$

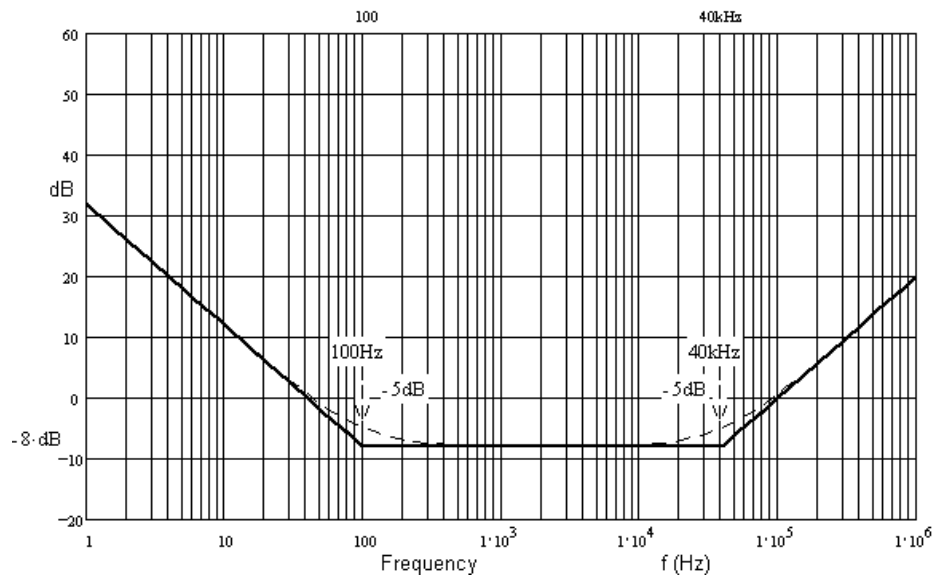

4. 
$$v_C(t) := 9 \cdot \text{V} + e^{-\frac{80}{\text{sec}} \cdot t} \cdot \left( -15 \cdot \text{V} \cdot \cos\left(\frac{400}{\text{sec}} \cdot t\right) - 2 \cdot \text{V} \cdot \sin\left(\frac{400}{\text{sec}} \cdot t\right) \right)$$

5. a) 6·mA 18·V b) 26·mA -4000· $\frac{\text{A}}{\text{sec}}$  c) 18·V 10000· $\frac{\text{V}}{\text{sec}}$