

# ECE 2210/00 Exam 2 given: Fall 05

(The space between problems has been removed.)

2. ( 10 pts) The following circuit has been connected as shown for a long time.

Find the energy stored in the capacitor and the inductor.

Also show the values of the voltage(s) and current(s) necessary to answer this question.

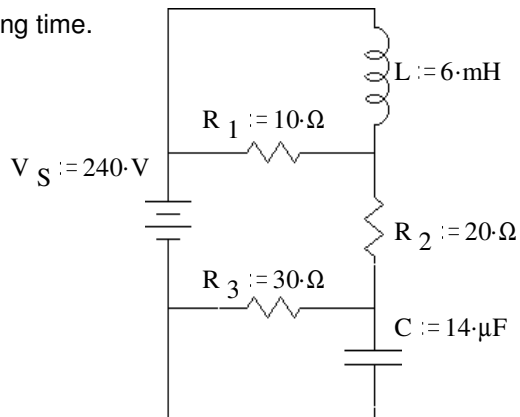

2. (22 pts) The current through a  $0.05 \mu\text{F}$  capacitor is shown below. Make an accurate drawing of the capacitor voltage. Label the y-axis of your graph (I've already done the x-axis). The initial voltage is the first line on the graph above zero. Your scale should tell me the value of that line.

Note: You will be graded on the accuracy of your plot at 0, 1, 2, 3, 7, and 8 ms, so calculate those values and plot or label them carefully. Between those points your plot must simply be the correct shape.

$C := 0.05 \mu\text{F}$

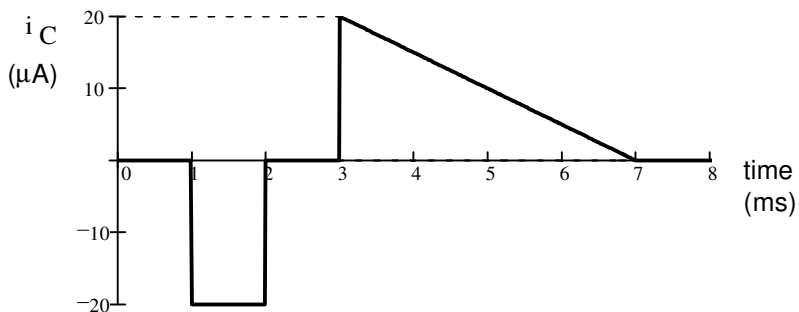

label this axis with numbers & units

Start at this line ----->  
You tell me what value it is by your scale

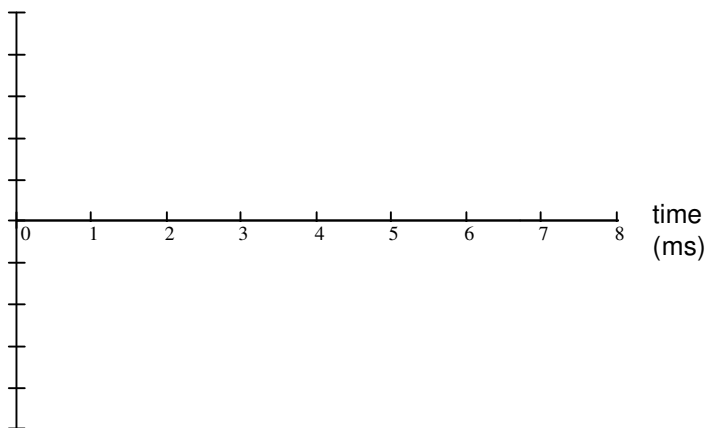

3. (25 pts) The switch has been closed (making contact) for a long time and is switched open (as shown) at time  $t = 0$ .

a) Find the complete expression for  $v_C(t)$ .

b) What is  $v_C$  when  $t = \tau$ ?  $v_C(\tau) = ?$

c) At time  $t = \tau$  the switch is closed again. Find the complete expression for  $v_C(t')$ , where  $t'$  starts at  $t = \tau$ . Be sure to clearly show the time constant.

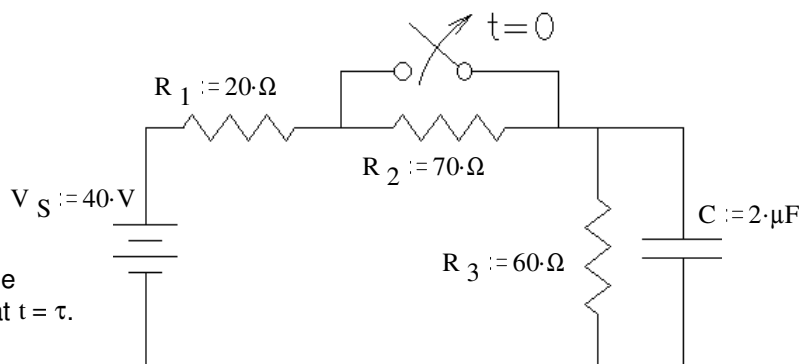

**ECE 2210/00 Exam 2 Fall 05 p2**

4. (24 pts)  $Z_{eq}$  is the total impedance between the two terminals.  
 Find  $Z_{eq}$  in simple polar form (give me numbers).  
 For partial credit, you must show work and/or intermediate results.  
 $f := 10\text{-kHz}$

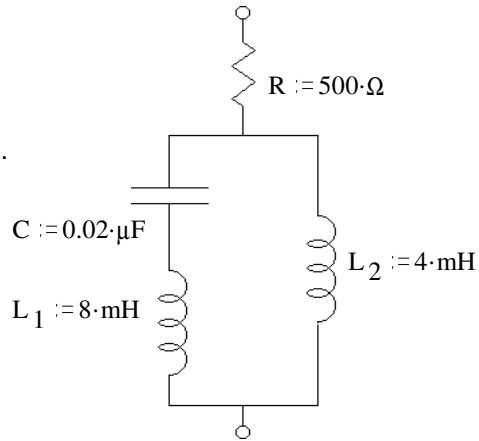

$Z_{eq} = \underline{\hspace{2cm}} / \underline{\hspace{2cm}}^\circ$   
 Polar Form

5. (22 pts) For partial credit, you must show work and/or intermediate results.  
 a) Find  $Z_1$

b) Find  $I_1$

c) Circle 1:

i)  $I_1$  leads  $I_2$

ii)  $I_1$  lags  $I_2$

$\underline{\hspace{2cm}} > \underline{\hspace{2cm}}$

$\underline{\hspace{2cm}} < \underline{\hspace{2cm}}$

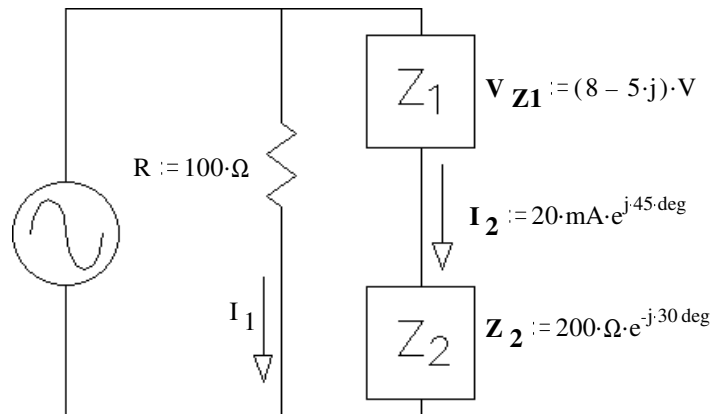

Why? Show numbers: Or explain by other means:

6. (7 pts)  $Z = 10 / 36^\circ \Omega$ , To make  $Z$  in the simplest way, what part(s) would you need?

Draw the parts and find the values.  $\omega := 50000 \cdot \frac{\text{rad}}{\text{sec}}$

**Answers**

1.  $I_L := 4.8 \cdot A$      $W_L := 69.1 \cdot \text{mJ}$      $V_C := 144 \cdot V$      $W_C := 145 \cdot \text{mJ}$

2. a)  $16 \cdot V + 14 \cdot V \cdot e^{-\frac{t}{72 \mu s}}$     b)  $21.15 \cdot V$     c)  $30 \cdot V - 8.85 \cdot V \cdot e^{-\frac{t}{30 \mu s}}$

3. Straight lines between the following points: (0ms,0.1A), (1ms,0.1A), (2ms,-0.3A), (3ms,-0.3A). Curves up, starting steep and ending flat at (7ms,0.5A), continues flat to (8ms, 0.5A). If you started with a different value than 0.1A then all other values would be correspondingly higher or lower.

4.  $Z_{eq} = 1832 \Omega / 74.2^\circ$

5. a)  $Z_1 = 472 / -77^\circ \Omega$     b)  $I_1 = 125 / -18.5^\circ \text{ mA}$

c) ii  $-18^\circ < 45^\circ$

6.  $8.09 \Omega$  resistor in series with  $0.118 \text{ mH}$  inductor.

ECE 2210/00 Exam 2

Name \_\_\_\_\_

Scores:

Page 1&2 \_\_\_\_\_ of a possible 32 pts

Page 3&4 \_\_\_\_\_ of a possible 39 pts

Page 5&6 \_\_\_\_\_ of a possible 29 pts

Total \_\_\_\_\_ of a possible 100 pts