

EE1050/60 Exam 2 given: Fall 01

(The space between problems has been removed.)

1. (16 pts) The following questions are similar to what you might see on the FE exam. You should be able to answer each of these in 2 minutes or less.

a) What is the resonant frequency of the circuit shown?

- (A) 450 Hz
- (B) 8 kHz
- (C) 50 kHz
- (D) 314 kHz
- (E) 2500 MHz

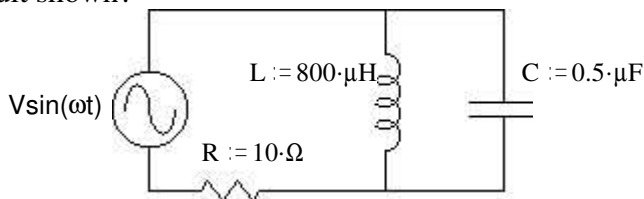

b) $\frac{2+j}{3-j4}$ is most nearly: (A) 0.45 $\angle 63^\circ$

- (B) 0.45 $\angle 80^\circ$
- (C) 2.24 $\angle -80^\circ$
- (D) 11.2 $\angle -27^\circ$
- (E) 12.2 $\angle 63^\circ$

c) Find I_2 in amps.

- (A) 3
- (B) 4.2
- (C) 12
- (D) 15
- (E) 21

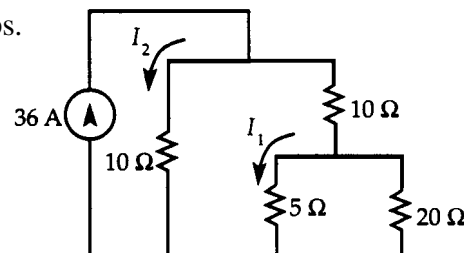

d) A voltage $v = 20 \cos 1500t$ volts is connected in series with a 40-ohm resistor and an RMS ammeter. The ammeter indication will be most nearly:

- (A) 0.27 A
- (B) 0.35 A
- (C) 0.5 A
- (D) 1.4 A
- (E) 566 A

2. (12 pts) The following circuit has been connected as shown for a long time.

Find the energy stored in the capacitor and the inductor.

Also show the values of the voltage(s) and current(s) necessary to answer this question.

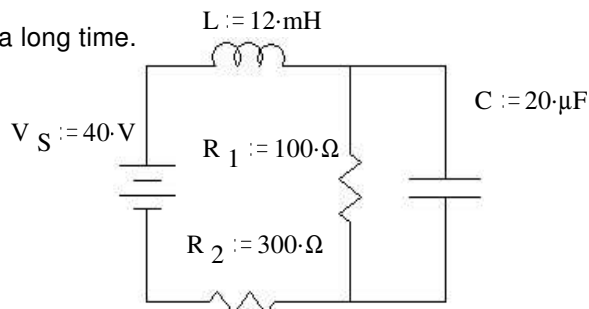

3. (18 pts) The voltage across a 6 μ F capacitor is shown below.

Make an accurate drawing of the capacitor current. Make reasonable assumptions where necessary. Label your graph.

Note: You will be graded on the accuracy of your plot at 0, 3, 6, 9, and 10 ms, so calculate those values and plot them carefully.

Between those points your plot must simply be the correct shape.

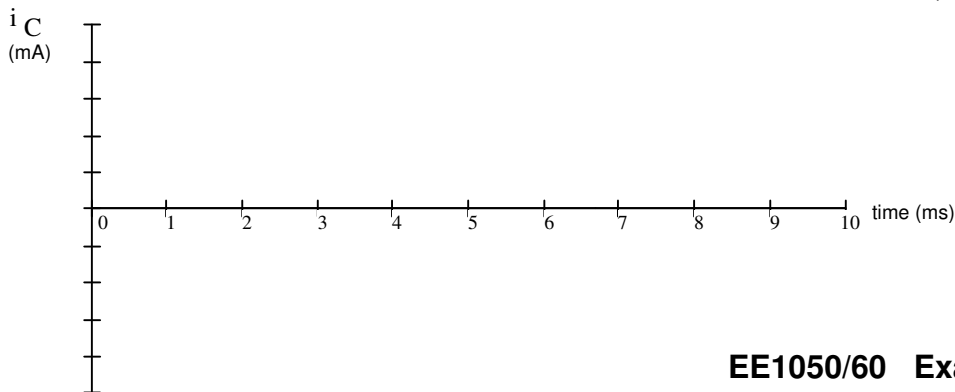
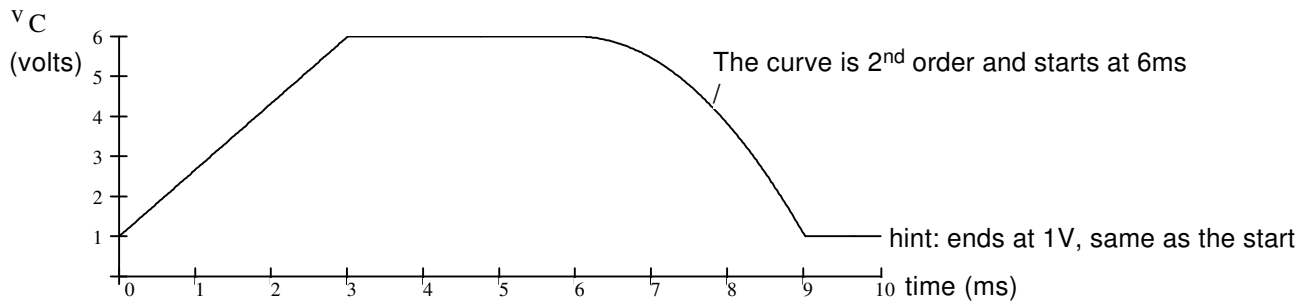

EE1050/60 Exam 2 given: Fall 01 p.2

4. (20 pts) The switch has been in the upper position for a long time and is switched down at time $t = 0$.
At what time is $v_C = 14$ V?

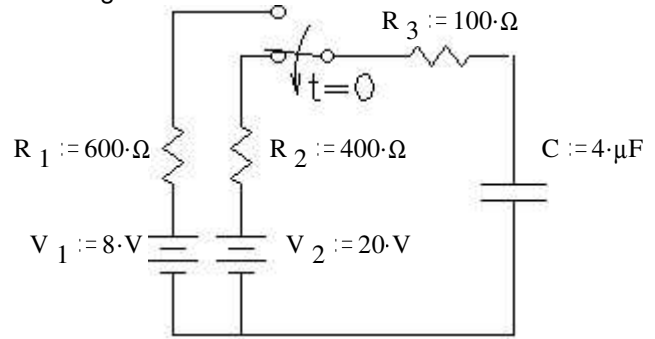

5. (20 pts) a) Find Z . Hint: Find the total impedance ($R+Z$) first.

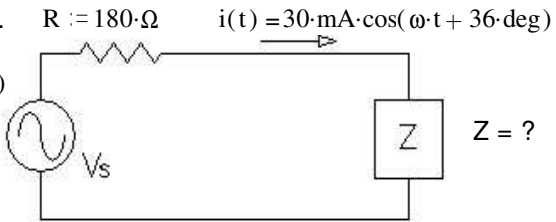

- b) Circle 1:
 i) The current leads the voltage
 ii) The voltage leads the current
 c) By how much? I.E. what is the phase angle between the voltage and current?

6. (14 pts) The two phasors shown represent two voltages, v_1 and v_2 .
 a) Draw the phasor representation for $v_3 = v_1 - v_2$ right on the figure. Note the **minus** sign.
 b) Find the magnitude of v_3 .
 c) Find the phase angle of v_3 .

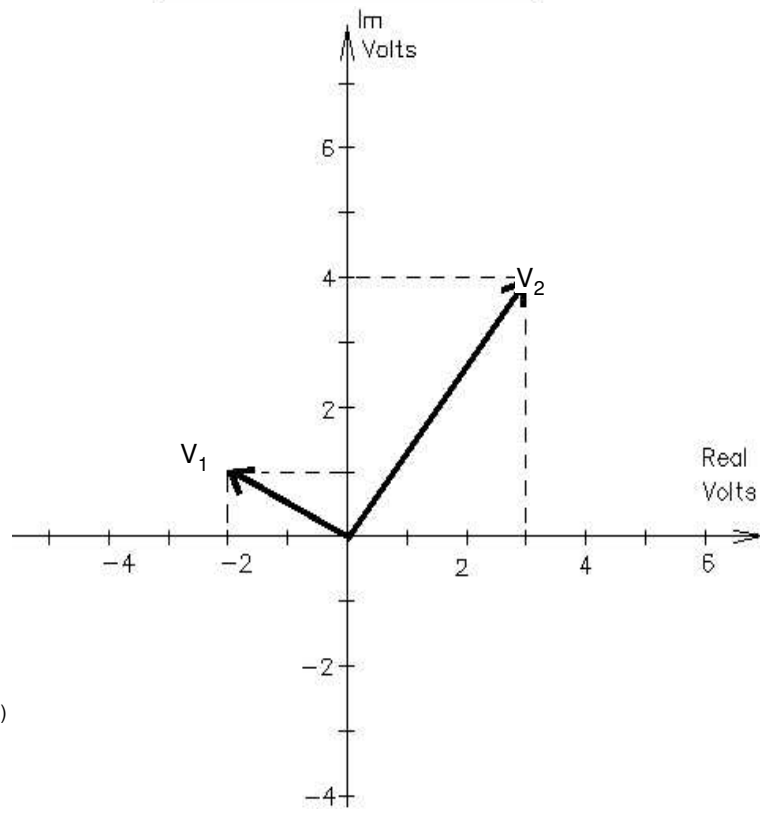

Answers

1. a) B b) B c) E d) B
 2. $I_L = 0.1A$ $W_L = 0.06mJ$ $V_C = 10V$ $W_C = 1mJ$

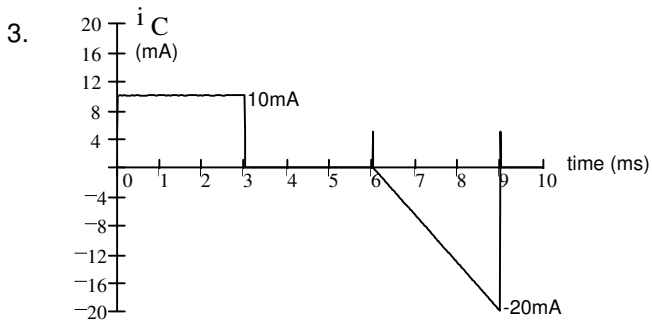

4. 1.39ms 5. a) $259 - 160j \Omega$ b) i c) 20°

5. a)
 b) 5.83V
 c) 211°

