

**ECE 2210/00 Exam 1 given: Spring 16** (The space between problems has been removed.)

Closed Book, Closed notes, Calculators OK, Show all work to receive credit

Circle answers, show units, and round off reasonably

To get the most possible partial credit, always show all the intermediate values that you can calculate. If further calculations depend on a value that you can't figure out, just use a letter (like  $I_{R1}$ ) or a guessed value and proceed.

1. (26 pts) Find the values below. Show your work. Feel free to show answers & work right on the schematic.

- a)  $R_3 = ?$
- b)  $R_4 = ?$
- c)  $V_S = ?$
- d)  $P_S = ?$

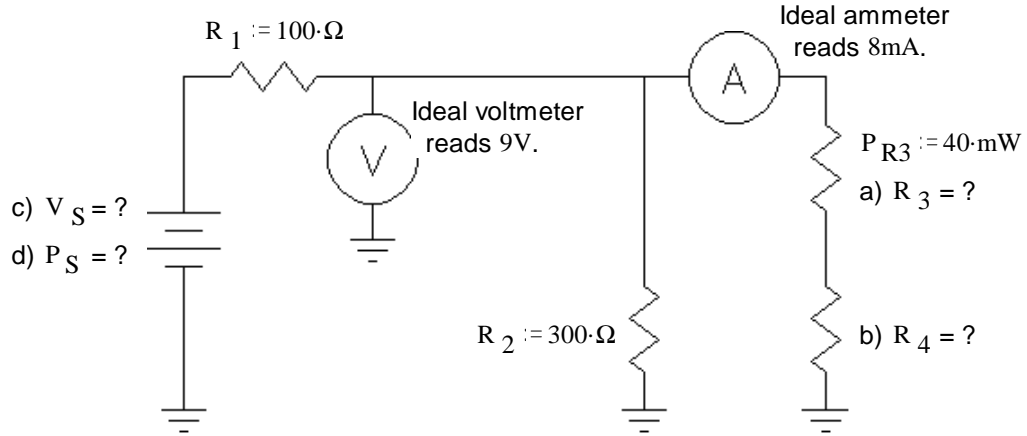

2. (25 pts) Use the method of superposition to find the current through  $R_1$  ( $I_{R1}$ ) and the voltage across  $R_3$  ( $V_{R3}$ ). Be sure to clearly show and **circle** your intermediate results.

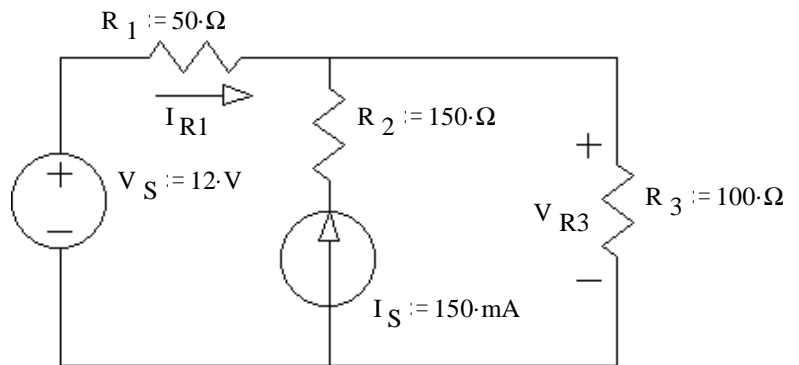

ECE 2210/00 Exam 1 Spring 16 p2

3. (25 pts) a) Find and draw the Thévenin equivalent of the circuit shown. The load resistor is  $R_L$ .

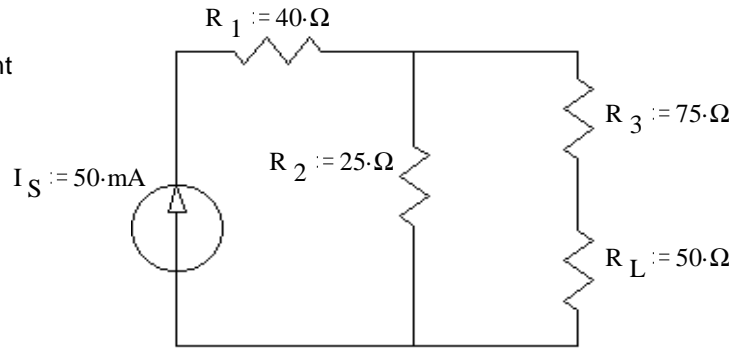

b) Find and draw the Norton equivalent of the same circuit.

c) Find the load voltage using your Thévenin equivalent circuit.

d) Choose a different value of  $R_L$  so as to maximize the power dissipated in  $R_L$ . Find that maximum power,  $P_L$ .

4. (25 pts) a) Use nodal analysis to find the voltage across  $R_2$  ( $V_{R2}$ ).

You **MUST** show all the steps of nodal analysis work to get credit, including drawing appropriate symbols and labels on the circuit shown.

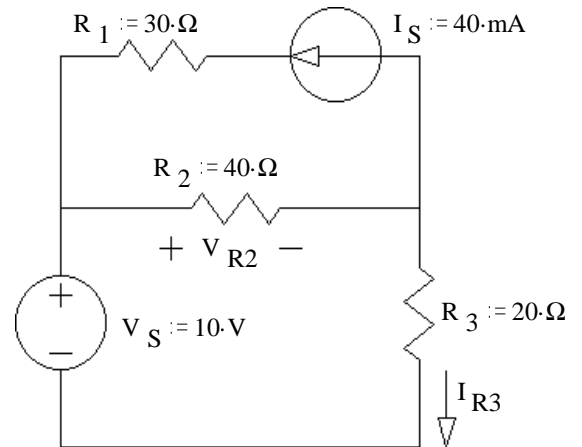

b) Find the current through  $R_3$  ( $I_{R3}$ ).

Folder Number \_\_\_\_\_

**Answers**

1. a)  $625 \cdot \Omega$     b)  $500 \cdot \Omega$     c)  $12.8 \cdot V$     d)  $486 \cdot mW$

2.  $-20 \cdot mA$      $13 \cdot V$

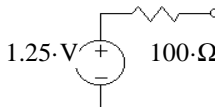
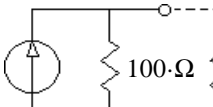
3. a)     b)     c)  $0.417 \cdot V$     b)  $3.9 \cdot mA$

4. a)  $7.2 \cdot V$     b)  $140 \cdot mA$