

# ECE 2210/00 Exam 1 given: Spring 09 (The space between problems has been removed.)

To get the most possible partial credit, always show all the intermediate values that you can calculate. If further calculations depend on a value that you can't figure out, just use a letter (like  $I_{R1}$ ) or a guessed value and proceed.

**Suggestion:** Do the last problem first. It's easy points.

1. (20 pts) Find the values below. Show your work

Note: feel free to show answers & work right on the schematic

- a)  $R_4 = ?$
- b)  $V_S = ?$
- c)  $P_S = ?$

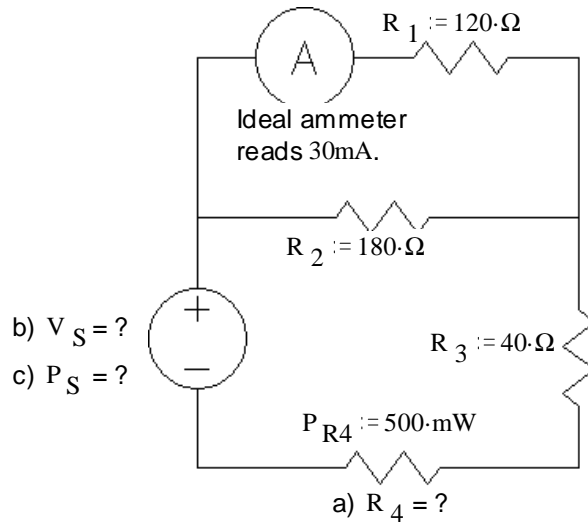

2. (20 pts) Use the method of superposition to find the voltage across  $R_1$  ( $V_{R1}$ ) and the current through  $R_3$  ( $I_{R3}$ ). Be sure to clearly show and **circle** your intermediate results.

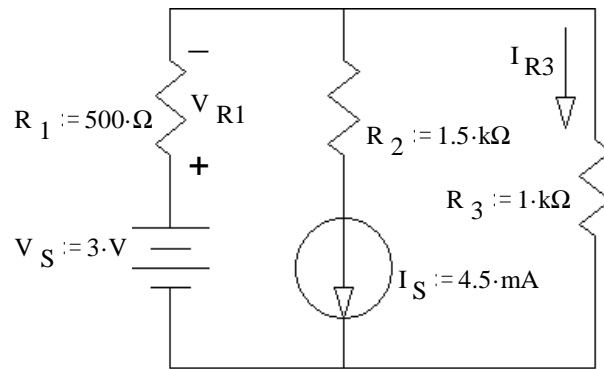

3. (22 pts) a) Find and draw the Thévenin equivalent of the circuit shown. The load resistor is  $R_L$ .

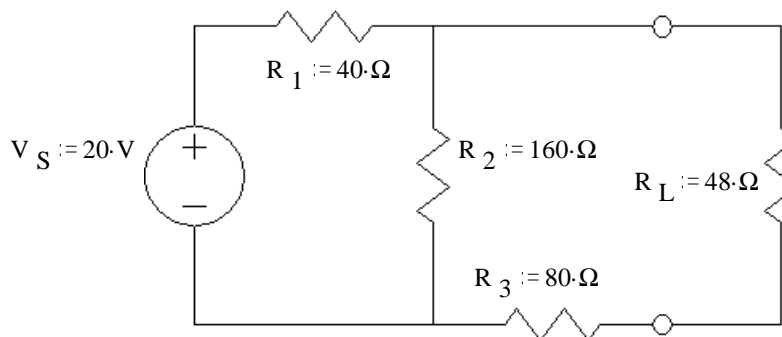

b) Find and draw the Norton equivalent of the same circuit.

c) Find the power dissipated in the load using your Thévenin equivalent circuit.  $P_{RL} = ?$

4. (20 pts) a) Use nodal analysis to find the voltage across  $R_2$  ( $V_{R2}$ ).

You **MUST** show all the steps of nodal analysis work to get credit, including drawing appropriate symbols and labels on the circuit shown.

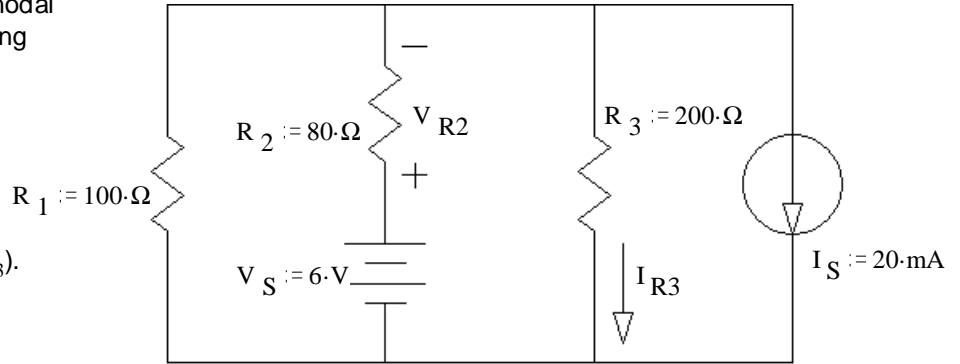

b) Find the current through  $R_3$  ( $I_{R3}$ ).

$I_{R3} = ?$

5. (18 pts) For the waveform shown, find:

- a) peak-to-peak voltage,  $V_{pp}$
- b) amplitude, A
- c) period, T
- d) frequency  $f$  in cycles/sec or Hz
- e) frequency  $\omega$  in radians/sec
- f) the phase angle in degrees
- g) a complete expression for  $v(t)$ , include numbers and units

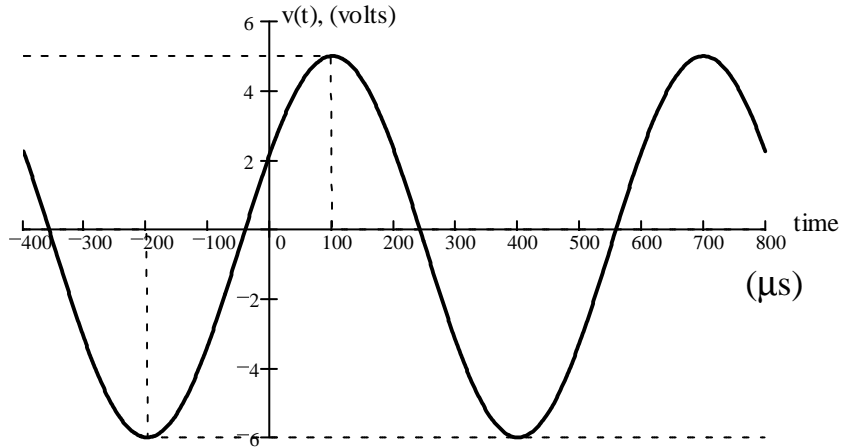

**Answers**

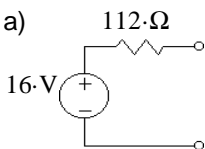
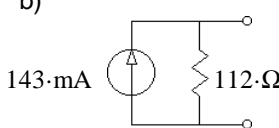
- 1. a)  $200\text{-}\Omega$       b)  $15.6\text{-V}$       c)  $780\text{-mW}$       2.  $0.5\text{-mA}$        $2.5\text{-V}$
- 3. a)       b)       c)  $480\text{-mW}$

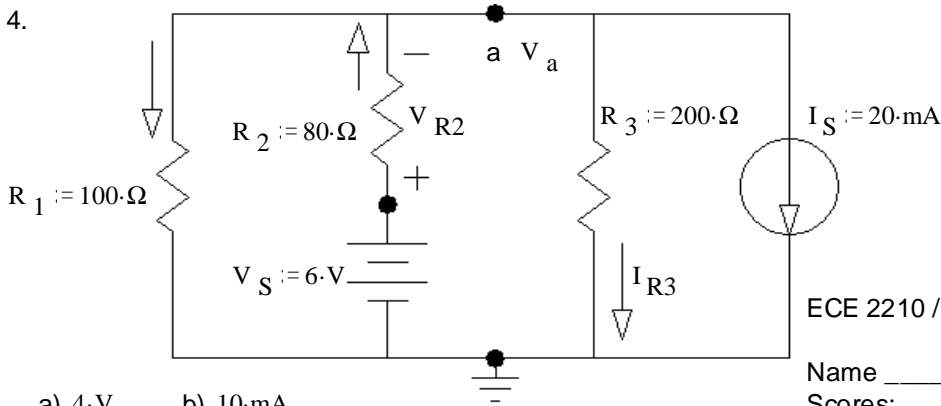

- a)  $4\text{-V}$       b)  $10\text{-mA}$

- 5 a)  $11\text{-V}$     b)  $5.5\text{-V}$     c)  $600\text{-}\mu\text{s}$     d)  $1.67\text{-kHz}$     e)  $10472\text{-}\frac{\text{rad}}{\text{sec}}$
- f)  $-60^\circ$       g)  $5.5\text{-V}\cdot\cos\left(10472\text{-}\frac{\text{rad}}{\text{sec}}\cdot t - 60\text{-deg}\right) - 0.5\text{-V}$

ECE 2210 / 00 Midterm #1 Arn Stolp

Name \_\_\_\_\_

Scores:

Pages 1&2 \_\_\_\_\_ of a possible 40 pts

Pages 3&4 \_\_\_\_\_ of a possible 42 pts

Page 5 \_\_\_\_\_ of a possible 18 pts

Total \_\_\_\_\_ of a possible 100 pts