

Complex Numbers

ECE 2210 / 00

A.Stolp
10/18/00
1/12/06

$j = \sqrt{-1}$ the imaginary number

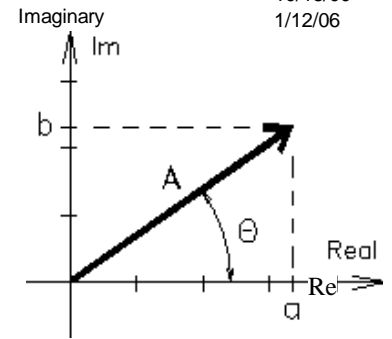

Rectangular Form $A = a + b \cdot j$

$$\text{Re}(A) = a \quad \text{Im}(A) = b$$

Polar Form $A = A \cdot e^{j\theta}$

$$\text{Re}(A) = A \cdot \cos(\theta) \quad \text{Im}(A) = A \cdot \sin(\theta)$$

Conversions $A = |A| = \sqrt{a^2 + b^2} \quad \theta = \arg(A) = \text{atan}\left(\frac{b}{a}\right)$

$$a = A \cdot \cos(\theta) \quad b = A \cdot \sin(\theta)$$

$$A = A \cdot e^{j\theta} = A \cdot \cos(\theta) + A \cdot \sin(\theta) \cdot j \quad A = a + b \cdot j = \left(\sqrt{a^2 + b^2}\right) \cdot e^{j \cdot \text{atan}\left(\frac{b}{a}\right)}$$

Special Cases $j := \sqrt{-1} = e^{j \cdot 90\text{-deg}} \quad \frac{1}{j} = -j = e^{-j \cdot 90\text{-deg}} \quad e^{j \cdot 0\text{-deg}} = 1 \quad e^{-j \cdot 180\text{-deg}} = e^{-j \cdot 180\text{-deg}} = -1$
 $j \cdot e^{j\theta} = e^{j(\theta + 90\text{-deg})}$

Define a 2nd number: rect: $D = c + d \cdot j$ polar: $D = D \cdot e^{j\phi}$

Equality $A = D$ if and only if $a = c$ and $b = d$ OR $A = D$ and $\theta = \phi$

Addition and Subtraction $A + D = (a + b \cdot j) + (c + d \cdot j) = (a + c) + (b + d) \cdot j$ Convert polars to rectangular form first
 $A - D = (a + b \cdot j) - (c + d \cdot j) = (a - c) + (b - d) \cdot j$

Multiplication and Division $A \cdot D = (a + b \cdot j) \cdot (c + d \cdot j) = (a \cdot c - b \cdot d) + (b \cdot c + a \cdot d) \cdot j$

$$\text{Rectangular: } \frac{A}{D} = \frac{a + b \cdot j}{c + d \cdot j} = \frac{a + b \cdot j \cdot c - d \cdot j}{c + d \cdot j \cdot c - d \cdot j} = \frac{a \cdot c + b \cdot d}{c^2 + d^2} + \frac{b \cdot c - a \cdot d}{c^2 + d^2} \cdot j$$

$$\text{Polar: } A \cdot D = A \cdot e^{j\theta} \cdot D \cdot e^{j\phi} = A \cdot D \cdot e^{j(\theta + \phi)}$$

$$\frac{A}{D} = \frac{A \cdot e^{j\theta}}{D \cdot e^{j\phi}} = \frac{A}{D} \cdot e^{j(\theta - \phi)}$$

Powers $A^n = A^n \cdot e^{j \cdot n \cdot \theta} = A^n \cdot \cos(n \cdot \theta) + A^n \cdot \sin(n \cdot \theta) \cdot j$ Convert rectangulars first, usually

Conjugates complex number $A = a + b \cdot j$ Conjugate $\overline{A} = a - b \cdot j$ $\overline{\overline{A}} = A$

$$A = A \cdot e^{j\theta} \quad \overline{A} = A \cdot e^{-j\theta}$$

$$F = \frac{3 + 5 \cdot j}{(2 - 6 \cdot j) \cdot e^{j \cdot 40\text{-deg}}} \quad \overline{F} = \frac{3 - 5 \cdot j}{(2 + 6 \cdot j) \cdot e^{-j \cdot 40\text{-deg}}}$$

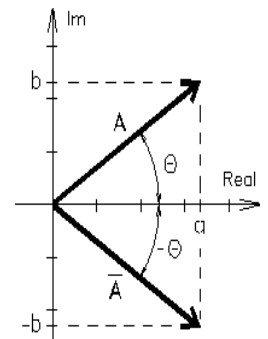

Euler's equation $e^{j\alpha} = \cos(\alpha) + j \cdot \sin(\alpha)$ OR: $\cos(\alpha) = \frac{e^{j\alpha} + e^{-j\alpha}}{2}$ $\sin(\alpha) = \frac{e^{j\alpha} - e^{-j\alpha}}{2 \cdot j}$

$$e^{j(\omega \cdot t + \theta)} = \cos(\omega \cdot t + \theta) + j \cdot \sin(\omega \cdot t + \theta)$$

$$\text{Re}\left[e^{j(\omega \cdot t + \theta)}\right] = \cos(\omega \cdot t + \theta)$$

If we freeze this at time $t=0$, then we can represent $\cos(\omega \cdot t + \theta)$ by $e^{j\theta}$

Calculus Remember, when we write $e^{j\theta}$, we really mean $e^{j(\omega \cdot t + \theta)}$

$$\frac{d}{dt} A = \frac{d}{dt} (A \cdot e^{j\theta}) = j \cdot \omega \cdot A \cdot e^{j\theta} = \omega \cdot A \cdot e^{j(\theta + 90\text{-deg})}$$

$$\int A dt = \int A \cdot e^{j\theta} dt = \frac{1}{j \cdot \omega} \cdot A \cdot e^{j\theta} = \frac{1}{\omega} \cdot A \cdot e^{j(\theta - 90\text{-deg})}$$

Phasor analysis with impedances, For steady-state sinusoidal response ONLY

Sinusoidal AC

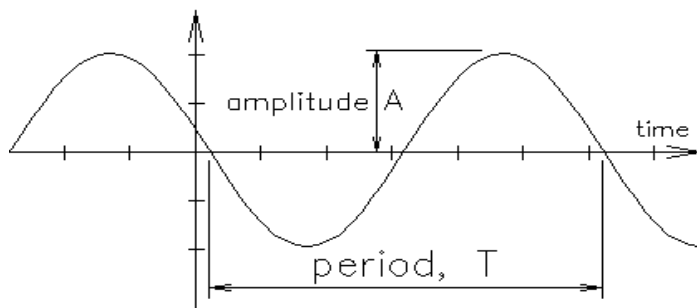

T = Period = repeat time

f = frequency, cycles / second $f = \frac{1}{T} = \frac{\omega}{2\pi}$

ω = radian frequency, radians/sec $\omega = 2\pi \cdot f$

A = amplitude

Phase: $\phi = -\frac{\Delta t}{T} \cdot 360\text{-deg}$

or: $\phi = -\frac{\Delta t}{T} \cdot 2\pi\text{-rad}$

$y(t) = A \cdot \cos(\omega \cdot t + \theta)$

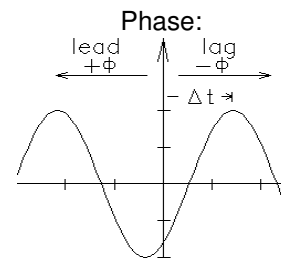

Phasor analysis The math is all based on the Euler's equation

Euler's equation $e^{j\alpha} = \cos(\alpha) + j \cdot \sin(\alpha)$

$\cos(\alpha) = \frac{e^{j\alpha} + e^{-j\alpha}}{2}$

OR:

$\sin(\theta) = \frac{e^{j\alpha} - e^{-j\alpha}}{2j}$

$e^{j(\omega t + \theta)} = \cos(\omega \cdot t + \theta) + j \cdot \sin(\omega \cdot t + \theta)$

$\text{Re}[e^{j(\omega t + \theta)}] = \cos(\omega \cdot t + \theta)$

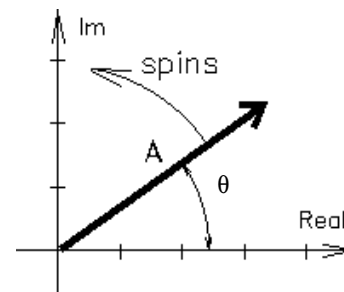

If we freeze this at time $t=0$, then we can represent $\cos(\omega \cdot t + \theta)$ by $e^{j\theta}$ That's the phasor

Phasor

voltage: $v(t) = V_p \cdot \cos(\omega \cdot t + \phi)$ $V(\omega) = V_p \cdot e^{j\phi}$

current: $i(t) = I_p \cdot \cos(\omega \cdot t + \phi)$ $I(\omega) = I_p \cdot e^{j\phi}$

Phasors are drawn on a complex plane.

Phasors are used for adding and subtracting sinusoidal waveforms.

Ex1. Add the sinusoidal voltages $v_1(t) = 4.5 \cdot V \cdot \cos(\omega \cdot t - 30\text{-deg})$
and $v_2(t) = 3.2 \cdot V \cdot \cos(\omega \cdot t + 15\text{-deg})$

using phasor notation, draw a phasor diagram of the three phasors, then convert back to time domain form.

$v_1(t) = 4.5 \cdot V \cdot \cos(\omega \cdot t - 30\text{-deg})$

$V_1(\omega) = 4.5V \angle -30^\circ$ or: $V_1(\omega) = 4.5 \cdot V \cdot e^{-j30\text{deg}}$

and

$v_2(t) = 3.2 \cdot V \cdot \cos(\omega \cdot t + 15\text{-deg})$

$V_2(\omega) = 3.2V \angle 15^\circ$ or: $V_2(\omega) = 3.2 \cdot V \cdot e^{j15\text{deg}}$

I'm going to drop the (ω) notation from the phasor notation, it gets cumbersome, but remember that phasors are in the frequency domain..

$V_1 = 4.5V \angle -30^\circ$ or: $V_1 := 4.5 \cdot V \cdot e^{-j30\text{deg}}$

$V_2 = 3.2V \angle 15^\circ$ or: $V_2 := 3.2 \cdot V \cdot e^{j15\text{deg}}$

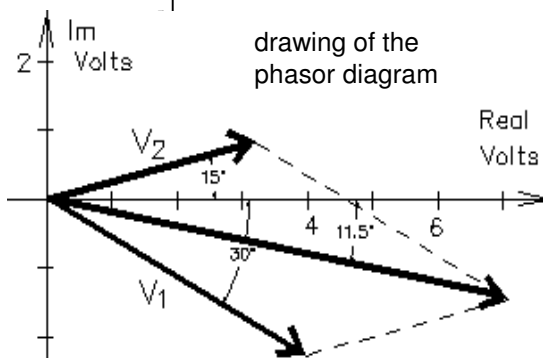
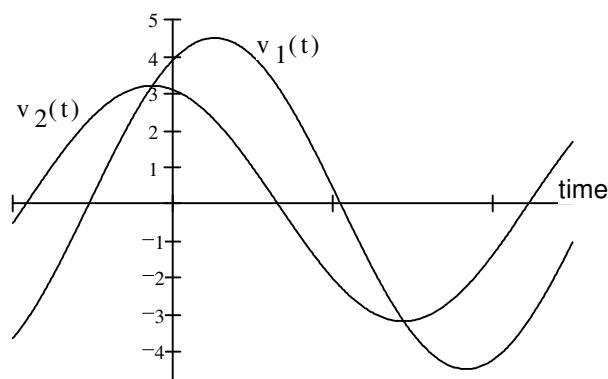

ECE 2210 / 00 Intro to Phasors p2

Add like vectors, first change to the rectangular form

$$\begin{array}{llll}
 \mathbf{V}_1 = 4.5\text{V} \angle -30^\circ & 4.5 \cdot \text{V} \cdot \cos(-30 \cdot \text{deg}) = 3.897 \cdot \text{V} & 4.5 \cdot \text{V} \cdot \sin(-30 \cdot \text{deg}) = -2.25 \cdot \text{V} & \mathbf{V}_1 = 3.897 - 2.25j \cdot \text{V} \\
 \mathbf{V}_2 = 3.2\text{V} \angle 15^\circ & 3.2 \cdot \text{V} \cdot \cos(15 \cdot \text{deg}) = 3.091 \cdot \text{V} & 3.2 \cdot \text{V} \cdot \sin(15 \cdot \text{deg}) = 0.828 \cdot \text{V} & \mathbf{V}_2 = 3.091 + 0.828j \cdot \text{V} \\
 & \text{Add real parts:} & 3.897 + 3.091 = 6.988 & \mathbf{V}_3 := \mathbf{V}_1 + \mathbf{V}_2 \\
 & \text{Add imaginary parts:} & -2.25 + 0.828 = -1.422 & \mathbf{V}_3 = 6.988 - 1.422j \cdot \text{V} \quad \text{sum}
 \end{array}$$

Change \mathbf{V}_3 back to polar coordinates:

$$\sqrt{6.988^2 + 1.422^2} = 7.131 \quad \text{atan}\left(\frac{-1.422}{6.988}\right) = -11.502 \cdot \text{deg}$$

OR, in Mathcad notation (you'll see these in future solutions):

$$|\mathbf{V}_3| = 7.131 \cdot \text{V} \quad \arg(\mathbf{V}_3) = -11.5 \cdot \text{deg}$$

Change \mathbf{V}_3 back to the time domain:

$$v_3(t) = v_1(t) + v_2(t) = 7.13 \cdot \cos(\omega t - 11.5 \cdot \text{deg}) \cdot \text{V}$$

Ex 2. Two sinusoidal voltages: $v_1(t) = 5 \cdot \text{V} \cdot \cos(\omega t + 36.87 \cdot \text{deg})$ and $v_2(t) = 3.162 \cdot \text{V} \cdot \cos(\omega t - 18.44 \cdot \text{deg})$

a) using phasor notation, find $v_3 = v_1 - v_2$

$$\mathbf{V}_1 := 5 \cdot \text{V} \cdot e^{j(36.87 \cdot \text{deg})} \quad \begin{array}{l} 5 \cdot \text{V} \cdot \cos(36.87 \cdot \text{deg}) = 4 \cdot \text{V} \\ 5 \cdot \text{V} \cdot \sin(36.87 \cdot \text{deg}) = 3 \cdot \text{V} \end{array}$$

$$\mathbf{V}_1 = 4 + 3j \cdot \text{V}$$

$$\mathbf{V}_2 := 3.162 \cdot \text{V} \cdot e^{j(-18.44 \cdot \text{deg})} \quad \begin{array}{l} 3.162 \cdot \text{V} \cdot \cos(-18.44 \cdot \text{deg}) = 3 \cdot \text{V} \\ 3.162 \cdot \text{V} \cdot \sin(-18.44 \cdot \text{deg}) = -1 \cdot \text{V} \end{array}$$

$$\mathbf{V}_2 = 3 - j \cdot \text{V}$$

Subtract real parts: $4 \cdot \text{V} - 3 \cdot \text{V} = 1 \cdot \text{V}$

Subtract imaginary parts: $3 \cdot \text{V} - (-1 \cdot \text{V}) = 4 \cdot \text{V}$

$$\mathbf{V}_3 := \mathbf{V}_1 - \mathbf{V}_2 \quad \mathbf{V}_3 = 1 + 4j \cdot \text{V}$$

$$\text{Magnitude: } \sqrt{(1 \cdot \text{V})^2 + (4 \cdot \text{V})^2} = 4.123 \cdot \text{V}$$

$$\text{Angle: } \text{atan}\left(\frac{4 \cdot \text{V}}{1 \cdot \text{V}}\right) = 75.96 \cdot \text{deg}$$

$$\text{So: } v_3(t) = v_1(t) - v_2(t) = 4.123 \cdot \text{V} \cdot \cos(\omega t + 75.96 \cdot \text{deg}) \cdot \text{V}$$

OR:

$$|\mathbf{V}_3| = 4.123 \cdot \text{V}$$

$$\arg(\mathbf{V}_3) = 75.96 \cdot \text{deg}$$

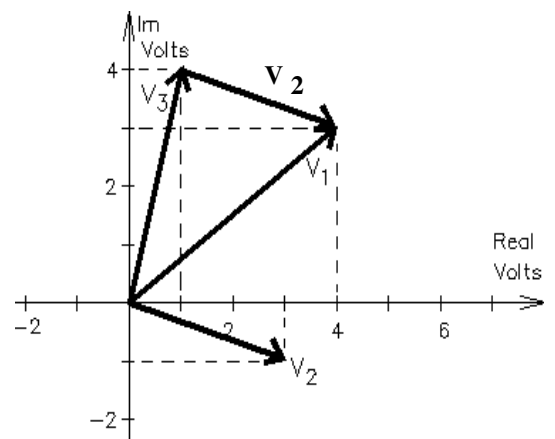
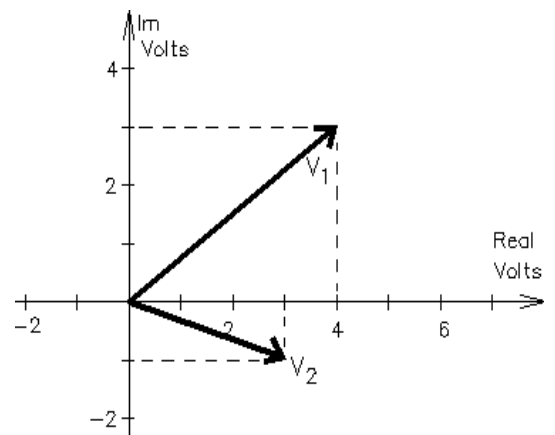

What about Capacitors and Inductors?

Capacitors and Inductors in AC circuits cause 90° phase shifts between voltages and currents because they integrate and differentiate. But... integration and differentiation is a piece-of-cake in phasors.

ECE 2210 / 00 Intro to Phasors p3

Calculus

$$\frac{d}{dt} [A \cdot e^{j(\omega t + \theta)}] = j \cdot \omega \cdot A \cdot e^{j(\omega t + \theta)} = \omega \cdot A \cdot e^{j(\omega t + \theta + 90 \text{ deg})} = \omega \cdot A \cdot e^{j(\theta + 90 \text{ deg})}$$

Drop the ωt ($t=0$) to get:

$$\int A \cdot e^{j(\omega t + \theta)} dt = \frac{1}{j \cdot \omega} \cdot A \cdot e^{j(\omega t + \theta)} = \frac{1}{\omega} \cdot A \cdot e^{j(\omega t + \theta - 90 \text{ deg})} = \frac{1}{\omega} \cdot A \cdot e^{j(\theta - 90 \text{ deg})}$$

Impedance (like resistance)

Inductor

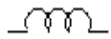

$$v_L = L \cdot \frac{d}{dt} i_L = L \cdot \frac{d}{dt} I_p \cdot e^{j(\omega t + \theta)} = j \cdot \omega \cdot L \cdot [I_p \cdot e^{j(\omega t + \theta)}]$$

in phasor notation ----> $V_L(\omega) = j \cdot \omega \cdot L \cdot I(\omega)$

AC impedance

$$Z_L = j \cdot \omega \cdot L$$

Capacitor

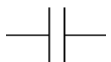

$$i_C = C \cdot \frac{d}{dt} v_C = C \cdot \frac{d}{dt} V_p \cdot e^{j(\omega t + \theta)} = j \cdot \omega \cdot C \cdot [V_p \cdot e^{j(\omega t + \theta)}]$$

in phasor notation ----> $I_C(\omega) = j \cdot \omega \cdot C \cdot V(\omega)$

$$V_C(\omega) = \frac{1}{j \cdot \omega \cdot C} \cdot I(\omega)$$

$$Z_C = \frac{1}{j \cdot \omega \cdot C} = \frac{-j}{\omega \cdot C}$$

Resistor



$$v_R = i_R \cdot R$$

$$V_R(\omega) = R \cdot I(\omega)$$

$$Z_R = R$$

You can use impedances just like resistances as long as you deal with the complex arithmetic. ALL the DC circuit analysis techniques will work with AC.

series:

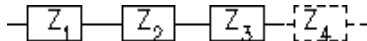

$$Z_{eq} = Z_1 + Z_2 + Z_3 + \dots$$

Example:

$$f := 500 \text{ Hz}$$

$$\omega := 2 \cdot \pi \cdot f = \omega = 3141.6 \cdot \frac{\text{rad}}{\text{sec}}$$

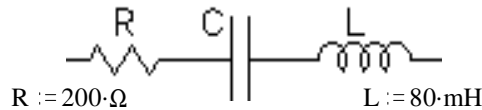

$$R := 200 \cdot \Omega$$

$$C := 0.6 \cdot \mu\text{F}$$

$$L := 80 \text{ mH}$$

$$j \cdot \omega \cdot L = 251.327j \cdot \Omega$$

$$\frac{1}{j \cdot \omega \cdot C} = -530.516j \cdot \Omega$$

$$Z_{eq} := R + \frac{1}{j \cdot \omega \cdot C} + j \cdot \omega \cdot L = 200 \cdot \Omega - 530.5j \cdot \Omega + 251.3j \cdot \Omega = 200 - 279.2j \cdot \Omega \quad \text{rectangular form}$$

$$\sqrt{(200 \cdot \Omega)^2 + (279.2 \cdot \Omega)^2} = 343.4 \cdot \Omega \quad \text{atan}\left(\frac{-279.2 \cdot \Omega}{200 \cdot \Omega}\right) = -54.38 \cdot \text{deg}$$

$$Z_{eq} = 343.4 \Omega \angle -54.4^\circ \quad \text{polar form}$$

If: $V := 12 \cdot V \cdot e^{j0 \text{ deg}}$

$$I := \frac{V}{Z_{eq}} = \frac{12 \cdot V}{343.4 \cdot \Omega} = 34.945 \cdot \text{mA} \quad \angle 0 - -54.4 = 54.4 \text{ deg}$$

$$I = 34.95 \text{ mA} \angle 54.4^\circ = I = 20.348 + 28.405j \cdot \text{mA}$$

Voltage divider:

$$V_{Zn} = V_{total} \cdot \frac{Z_n}{Z_1 + Z_2 + Z_3} + \dots$$

Note: $\frac{1}{j} = -j = 1 \angle -90^\circ$

Eg: $V_C := V \cdot \frac{1}{Z_{eq}} = 12 \cdot V \cdot e^{j0 \text{ deg}} \cdot \frac{530.516 \cdot e^{-j90 \text{ deg}} \cdot \Omega}{343.4 \cdot e^{-j54.38 \text{ deg}} \cdot \Omega}$

$$12 \cdot V \cdot \frac{530.516 \cdot \Omega}{343.4 \cdot \Omega} = 18.539 \cdot V \quad \angle 0 + -90 - -54.4 = -35.6 \text{ deg}$$

ECE 2210 / 00 Intro to Phasors p3

$$V_C = 18.54 \text{ V} \angle -35.6^\circ = V_C = 15.069 - 10.795j \cdot V$$

parallel:

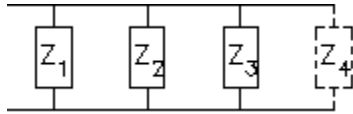

$$Z_{eq} = \frac{1}{\frac{1}{Z_1} + \frac{1}{Z_2} + \frac{1}{Z_3} + \dots}$$

Example:

$f := 500\text{-Hz}$ $\omega := 2 \cdot \pi \cdot f$ $\omega = 3141.6 \frac{\text{rad}}{\text{sec}}$

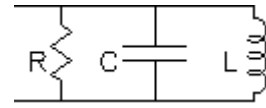

$R := 200\text{-}\Omega$ $C := 0.6\text{-}\mu\text{F}$ $L := 80\text{-mH}$
 $\frac{1}{\omega \cdot L} = 3.979 \cdot 10^{-3} \frac{1}{\Omega}$

$\frac{1}{j \cdot \omega \cdot C} = -530.516j \cdot \Omega$

$\omega \cdot C = 1.885 \cdot 10^{-3} \frac{1}{\Omega}$

$$Z_{eq} := \frac{1}{\frac{1}{R} + \frac{1}{\left(\frac{1}{j \cdot \omega \cdot C}\right)} + \frac{1}{j \cdot \omega \cdot L}} = \frac{1}{\frac{1}{R} + j \cdot \omega \cdot C - \frac{j}{\omega \cdot L}} = \frac{1}{\frac{1}{200\text{-}\Omega} + 1.885 \cdot 10^{-3} j \cdot \frac{1}{\Omega} - 3.979 \cdot 10^{-3} j \cdot \frac{1}{\Omega}}$$

$$= \frac{1}{\left(5 \cdot 10^{-3} - 2.094 \cdot 10^{-3} j\right) \cdot \frac{1}{\Omega}} = \frac{5 \cdot 10^{-3} + 2.094 \cdot 10^{-3} j}{\left(5 \cdot 10^{-3} - 2.094 \cdot 10^{-3} j\right) \cdot \frac{1}{\Omega}} = 170.156 + 71.261j \cdot \Omega$$

$$= \frac{1}{2.93848 \cdot 10^{-5}}$$

If you want the answer in polar form, it's easier to convert the denominator first.

$$\sqrt{\left(5 \cdot 10^{-3} \cdot \frac{1}{\Omega}\right)^2 + \left(2.094 \cdot 10^{-3} \cdot \frac{1}{\Omega}\right)^2} = 5.4 \cdot 10^{-3} \cdot \frac{1}{\Omega} \quad \text{atan}\left(\frac{-2.094 \cdot 10^{-3} \cdot \Omega}{5 \cdot 10^{-3} \cdot \Omega}\right) = -22.72 \cdot \text{deg}$$

$$\frac{1}{5.4 \cdot 10^{-3} \cdot \frac{1}{\Omega}} = 185.185 \cdot \Omega$$

$Z_{eq} = 185.2 \angle 22.7^\circ$

If: $V := 12 \cdot V \cdot e^{j \cdot 0 \cdot \text{deg}}$ $I := \frac{V}{Z_{eq}} = \frac{12 \cdot V}{185.2 \cdot \Omega} = 64.795 \cdot \text{mA} \angle 0 - 22.7 = -22.7 \text{ deg}$

$I = 60 - 25.127j \cdot \text{mA}$

Current divider:

$$I_{Zn} = I_{total} \cdot \frac{\frac{1}{Z_n}}{\frac{1}{Z_1} + \frac{1}{Z_2} + \frac{1}{Z_3} + \dots}$$

Eg: $I_L := I \cdot \frac{\frac{1}{j \cdot \omega \cdot L}}{\frac{1}{R} + j \cdot \omega \cdot C + \frac{1}{j \cdot \omega \cdot L}} = I \cdot \frac{Z_{eq}}{j \cdot \omega \cdot L}$

$$= 64.795 \cdot \text{mA} \cdot e^{j \cdot 22.7 \cdot \text{deg}} \cdot \frac{185.2 \cdot e^{-j \cdot 22.7 \cdot \text{deg}} \cdot \Omega}{251.327 \cdot e^{j \cdot 90 \cdot \text{deg}} \cdot \Omega}$$

$$= 64.795 \cdot \text{mA} \cdot \frac{185.2 \cdot \Omega}{251.327 \cdot \Omega} = 47.747 \cdot \text{mA} \angle 22.7 + -22.7 - 90 = -90 \text{ deg} \quad I_L = -47.746j \cdot \text{mA}$$

ECE 2210 / 00 Phasor Examples

Ex 1. Find V_R , V_L , and V_C in polar phasor form. $f := 2\text{-kHz}$

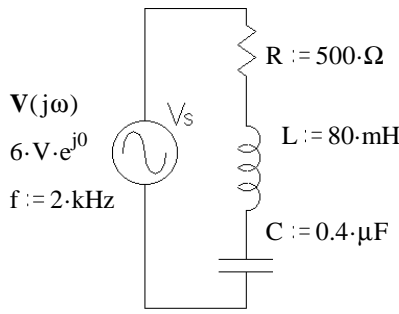

$$\omega := 2 \cdot \pi \cdot f \quad \omega = 1.257 \cdot 10^4 \frac{\text{rad}}{\text{sec}}$$

$$Z_L := j \cdot \omega \cdot L \quad Z_L = 1.005j \cdot \text{k}\Omega$$

$$Z_C := \frac{1}{j \cdot \omega \cdot C} \quad Z_C = -0.199j \cdot \text{k}\Omega$$

$$Z_{eq} := R + j \cdot \omega \cdot L + \frac{1}{j \cdot \omega \cdot C} \quad Z_{eq} = 500 + 806.366j \cdot \Omega$$

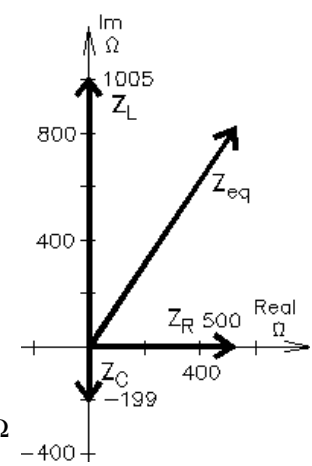

$$\sqrt{500^2 + 806^2} = 948.491 \quad \text{atan}\left(\frac{806}{500}\right) = 58.187 \cdot \text{deg} \quad Z_{eq} = 948.5 \Omega / 58.2^\circ$$

find the current: $I := \frac{6 \cdot V \cdot e^{j0}}{Z_{eq}}$ magnitude: $\frac{6 \cdot V}{948.5 \Omega} = 6.326 \cdot \text{mA}$ angle: $0 \cdot \text{deg} - 58.2 \cdot \text{deg} = -58.2 \cdot \text{deg}$

$I = 6.326 \text{mA} / -58.2^\circ$

find the magnitude find the angle

$V_R := I \cdot R$	$6.326 \cdot \text{mA} \cdot 500 \cdot \Omega = 3.163 \cdot V$	$-58.2 \cdot \text{deg} + 0 \cdot \text{deg} = -58.2 \cdot \text{deg}$	$V_R = 3.163V / -58.2^\circ$
$V_L := I \cdot Z_L$	$6.326 \cdot \text{mA} \cdot 1005 \cdot \Omega = 6.358 \cdot V$	$-58.2 \cdot \text{deg} + 90 \cdot \text{deg} = 31.8 \cdot \text{deg}$	$V_L = 6.358V / 31.8^\circ$
$V_C := I \cdot Z_C$	$6.326 \cdot \text{mA} \cdot (-199) \cdot \Omega = -1.259 \cdot V$	$-58.2 \cdot \text{deg} + (90) \cdot \text{deg} = 31.8 \cdot \text{deg}$	$V_C = -1.259V / 31.8^\circ$
OR:	$6.326 \cdot \text{mA} \cdot (199) \cdot \Omega = 1.259 \cdot V$	$-58.2 \cdot \text{deg} + (-90) \cdot \text{deg} = -148.2 \cdot \text{deg}$	$V_C = 1.259V / -148.2^\circ$

OR, you can also find these voltages directly, using a voltage divider. I.E. to find V_C directly:

$$V_C := \frac{\frac{1}{j \cdot \omega \cdot C}}{R + j \cdot \omega \cdot L + \frac{1}{j \cdot \omega \cdot C}} \cdot 6 \cdot V = \frac{1}{R \cdot (j \cdot \omega \cdot C) + j \cdot \omega \cdot L \cdot (j \cdot \omega \cdot C) + 1} \cdot 6 \cdot V = \frac{1}{R \cdot (j \cdot \omega \cdot C) - \omega^2 \cdot L \cdot C + 1} \cdot 6 \cdot V$$

$$= \frac{1}{(1 - \omega^2 \cdot L \cdot C) + j \cdot \omega \cdot R \cdot C} \cdot 6 \cdot V \quad (1 - \omega^2 \cdot L \cdot C) = -4.053 \quad j \cdot \omega \cdot R \cdot C = 2.513j$$

$$= \frac{6 \cdot V}{-4.053 + 2.513j} \cdot \frac{(-4.053 - 2.513j)}{(-4.053 - 2.513j)} = \frac{6 \cdot V \cdot (-4.053 - 2.513j)}{(-4.053)^2 + 2.513^2}$$

$$6 \cdot V \cdot (-4.053 - 2.513j) = -24.318 - 15.078j \cdot V$$

$$(-4.053)^2 + 2.513^2 = 22.742$$

$$= \left(\frac{-24.318}{22.742} - \frac{15.078j}{22.742} \right) \cdot V = -1.069 - 0.663j \cdot V$$

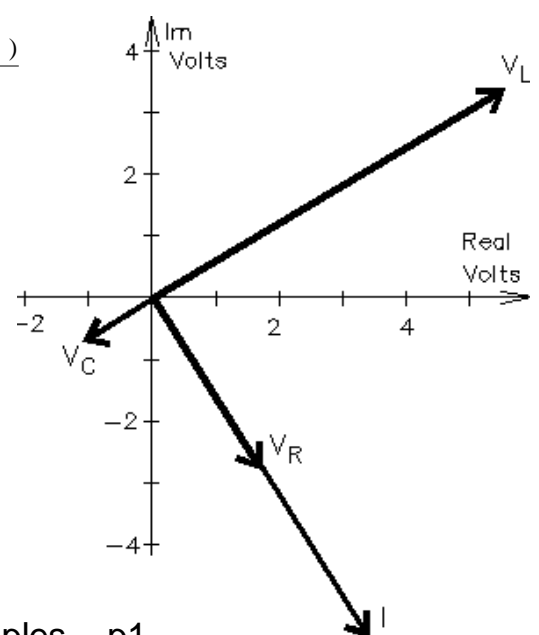

magnitude: $\sqrt{1.069^2 + 0.663^2} = 1.258$

angle: $\text{atan}\left(\frac{-0.663}{-1.069}\right) = 31.81 \cdot \text{deg}$

but this is actually in the third quadrant, so modify your calculator's results:

$$31.81 \cdot \text{deg} - 180 \cdot \text{deg} = -148.19 \cdot \text{deg}$$

$$= 1.258V / -148.2^\circ$$

ECE 2210 / 00 Phasor Examples p2

Ex 2. a) Find Z_{eq} . $f := 2.5 \cdot \text{kHz}$ $\omega := 2 \cdot \pi \cdot f$ $\omega = 1.571 \cdot 10^4 \frac{\text{rad}}{\text{sec}}$

$$Z_{eq} = j \cdot \omega \cdot L_1 + \frac{1}{\left(\frac{1}{j \cdot \omega \cdot C}\right) + \frac{1}{R + j \cdot \omega \cdot L_2}}$$

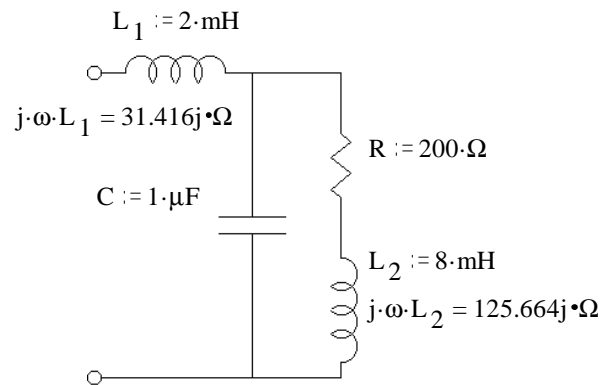

But it's easier to split the problem up

Left branch

$$Z_1 := \frac{1}{j \cdot \omega \cdot C} \quad Z_1 = -63.662j \cdot \Omega$$

$$\left(\frac{1}{j \cdot \omega \cdot C}\right) = j \cdot \omega \cdot C = 0.01571i \cdot \frac{1}{\Omega}$$

Right branch

$$Z_R := j \cdot \omega \cdot L_2 + R \quad Z_R = 200 + 125.664j \cdot \Omega$$

$$\frac{1}{200 + 125.664j} = 3.585 \cdot 10^{-3} - 2.252 \cdot 10^{-3}j$$

denominator: $j \cdot \omega \cdot C + \frac{1}{R + j \cdot \omega \cdot L_2} = 0.01571j + (3.585 \cdot 10^{-3} - 2.252 \cdot 10^{-3}j) = 3.585 \cdot 10^{-3} + 1.346 \cdot 10^{-2}i \frac{1}{\Omega}$

rectangular division:

$$\frac{1}{(3.585 \cdot 10^{-3} + 1.346 \cdot 10^{-2}j)} \cdot \frac{(3.585 \cdot 10^{-3} - 1.346 \cdot 10^{-2}j)}{(3.585 \cdot 10^{-3} - 1.346 \cdot 10^{-2}j)} = \frac{3.585 \cdot 10^{-3} - 1.346 \cdot 10^{-2}j}{1.94 \cdot 10^{-4}} = 18.479 - 69.381j \quad \Omega$$

$$(3.585 \cdot 10^{-3})^2 + (1.346 \cdot 10^{-2})^2 = 1.94 \cdot 10^{-4}$$

add: $j \cdot \omega \cdot L_1 = 31.416j \cdot \Omega$ $31.416j + (18.479 - 69.381j) = 18.479 - 37.965j \quad \Omega$

convert to polar (if needed): $\sqrt{18.48^2 + 37.97^2} = 42.228$ $\text{atan}\left(\frac{-37.97}{18.48}\right) = -64.048 \cdot \text{deg}$ $Z_{eq} = 42.23\Omega \angle -64.05^\circ$

Another Way

Sometimes you might simplify a little before putting in numbers.

$$Z_{eq} := j \cdot \omega \cdot L_1 + \frac{1}{\frac{1}{R + j \cdot \omega \cdot L_2} + \frac{1}{j \cdot \omega \cdot C}} = j \cdot \omega \cdot L_1 + \frac{1}{\frac{1}{R + j \cdot \omega \cdot L_2} + j \cdot \omega \cdot C} = j \cdot \omega \cdot L_1 + \frac{R + j \cdot \omega \cdot L_2}{1 + j \cdot \omega \cdot C \cdot (R + j \cdot \omega \cdot L_2)}$$

$$= j \cdot \omega \cdot L_1 + \frac{R + j \cdot \omega \cdot L_2}{1 - \omega^2 \cdot C \cdot L_2 + j \cdot \omega \cdot C \cdot R}$$

$$Z_{eq} = 31.416j \cdot \Omega + \frac{(200 + 125.664j) \cdot \Omega}{-0.974 + 3.142j} \cdot \frac{(-0.974 - 3.142j)}{(-0.974 - 3.142j)} = 31.416j \cdot \Omega + \frac{(200 + 125.664j) \cdot (-0.974 - 3.142j)}{0.974^2 + 3.142^2}$$

$$= 31.416j \cdot \Omega + \frac{((200 \cdot (-0.974) - 125.664 \cdot (-3.142)) + (125.664 \cdot (-0.974) - 200 \cdot 3.142)j) \cdot \Omega}{0.974^2 + 3.142^2}$$

$$= 31.416j \cdot \Omega + \frac{(200.036288 - 750.796736j) \cdot \Omega}{10.82084} = 31.416j \cdot \Omega + 18.486 \cdot \Omega - 69.384j \cdot \Omega = 18.486 - 37.968j \quad \Omega$$

$$\sqrt{18.49^2 + 37.97^2} = 42.233 \quad \text{atan}\left(\frac{-37.97}{18.49}\right) = -64.036 \cdot \text{deg} \quad Z_{eq} = 42.23\Omega \angle -64.04^\circ$$

b) $V_{in} := 12 \cdot V \cdot e^{j \cdot 20 \cdot \text{deg}}$ Find I_{L1} , V_C $I_{L1} := \frac{V_{in}}{Z_{eq}} = \frac{12 \cdot V}{42.23 \cdot \Omega} = 284.16 \cdot \text{mA}$ $20 \cdot \text{deg} - (-64.04) \cdot \text{deg} = 84.04 \cdot \text{deg}$

$I_{L1} = 284 \text{mA} / 84.04^\circ$

$V_C := I_{L1} \cdot (18.479 - 69.381 \cdot j) \cdot \Omega = 284 \cdot \text{mA} \cdot \sqrt{18.479^2 + 69.381^2} \cdot \Omega = 20.391 \cdot V$

$84.04 \cdot \text{deg} + \text{atan}\left(\frac{-69.381}{18.479}\right) = 8.954 \cdot \text{deg}$

$V_C = 20.4 \text{V} / 8.95^\circ$

You could then use another voltage divider to find V_R or V_{L2} .

convert to rectangular (if needed): $20.391 \cdot V \cdot \cos(8.954 \cdot \text{deg}) = 20.143 \cdot V$

$20.391 \cdot V \cdot \sin(8.954 \cdot \text{deg}) = 3.174 \cdot V$

$V_C = 20.14 + 3.174 \cdot j \text{ V}$

Another Way

To find V_C

directly:

$$V_C := \frac{\frac{1}{R + j \cdot \omega \cdot L_2}}{j \cdot \omega \cdot L_1 + \frac{1}{R + j \cdot \omega \cdot L_2}} \cdot V_{in}$$

--> math --> $V_C = 20.153 + 3.178j \text{ V}$ Same but for a little roundoff difference

c) Let's find I_{L2} . $Z_r = 200 + 125.664j \cdot \Omega$ $\sqrt{200^2 + 125.664^2} = 236.202$ $\text{atan}\left(\frac{125.664}{200}\right) = 32.142 \cdot \text{deg}$

$I_{L2} := \frac{V_C}{Z_r} = \frac{20.4 \cdot V \cdot e^{j \cdot 8.95 \cdot \text{deg}}}{236.202 \cdot \Omega \cdot e^{j \cdot 32.142 \cdot \text{deg}}} = \frac{20.4 \cdot V}{236.202 \cdot \Omega} / 8.95 - 32.142^\circ = 86.4 \text{mA} / -23.19^\circ$

Another Way

Directly by Current divider:

$$I_{L2} := \frac{\frac{1}{R + j \cdot \omega \cdot L_2}}{j \cdot \omega \cdot C + \frac{1}{R + j \cdot \omega \cdot L_2}} \cdot I_{L1} = \frac{1}{j \cdot \omega \cdot C \cdot (R + j \cdot \omega \cdot L_2) + 1} \cdot I_{L1} = \frac{I_{L1}}{1 - \omega^2 \cdot C \cdot L_2 + j \cdot \omega \cdot C \cdot R}$$

real part is negative

denominator: $\sqrt{(1 - \omega^2 \cdot C \cdot L_2)^2 + (\omega \cdot C \cdot R)^2} = 3.289$ $\text{atan}\left(\frac{\omega \cdot C \cdot R}{1 - \omega^2 \cdot C \cdot L_2}\right) + 180 \cdot \text{deg} = 107.224 \cdot \text{deg}$

$I_{L2} = \frac{284 \cdot \text{mA} \cdot e^{j \cdot 84.04 \cdot \text{deg}}}{3.289 \cdot e^{j \cdot 107.224 \cdot \text{deg}}} = \frac{284 \cdot \text{mA}}{3.289} / 84.04 - 107.224^\circ = 86.4 \text{mA} / -23.18^\circ$

d) How about I_C ? $I_C := \frac{V_C}{\left(\frac{1}{j \cdot \omega \cdot C}\right)} = V_C \cdot j \cdot \omega \cdot C = 20.4 \text{V} / 8.95^\circ \cdot 0.015708 / 90^\circ \cdot \frac{1}{\Omega} = 320 \text{mA} / 98.95^\circ$

Another Way Could also be found directly by current divider: $I_C := \frac{j \cdot \omega \cdot C}{j \cdot \omega \cdot C + \frac{1}{R + j \cdot \omega \cdot L_2}} \cdot I_{L1} = 320 \text{mA} / 98.95^\circ$

Something Weird

I_C is greater than the input current (I_{L1}). What's going on?

The angle between I_C & I_{L2} is big enough that they somewhat cancel each other out (partially resonate).

Check Kirchoff's Current Law: $I_C + I_{L2} = 29.485 + 282.569j \text{ mA} = I_{L1} = 29.485 + 282.569j \text{ mA}$
?
yes

ECE 2210 / 00 Phasor Examples p4

Ex 3. a) Find Z_2 .

$$I := 25 \cdot \text{mA} \cdot e^{j \cdot 10 \cdot \text{deg}}$$

$$V_{in} := 10 \cdot \text{V} \cdot e^{-j \cdot 20 \cdot \text{deg}}$$

$$Z_T := \frac{V_{in}}{I} = \frac{10 \cdot \text{V}}{25 \cdot \text{mA}} \angle_{-20 - 10} = 400 \Omega \angle_{-30}$$

$$Z_T = 346.41 - 200j \cdot \Omega$$

$$Z_2 := Z_T - R - Z_1 = (346.41 - 200j) \cdot \Omega - 50 \cdot \Omega - (120 - 60j) \cdot \Omega = 176.41 - 140j \cdot \Omega$$

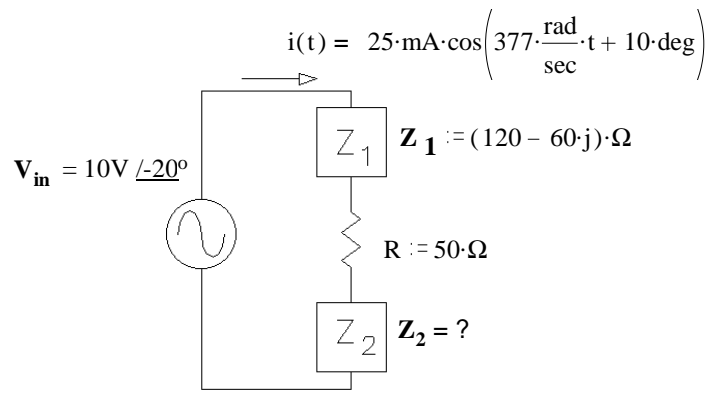

- b) Circle 1: i) The source current leads the source voltage <--- answer, because $10^\circ > -20^\circ$
 ii) The source voltage leads the source current

Ex 4. a) Find V_{in} in polar form.

$$I_Z := 100 \cdot \text{mA} \quad Z := (80 - 60j) \cdot \Omega$$

$$V_{in} := I_Z \cdot Z \quad V_{in} = 8 - 6j \cdot \text{V}$$

$$\sqrt{8^2 + 6^2} = 10 \quad \text{atan}\left(\frac{-6}{8}\right) = -36.87 \cdot \text{deg}$$

$$V_{in} = 10 \text{V} \angle_{-36.9}$$

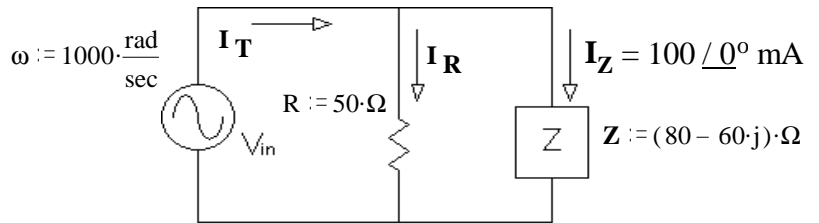

- b) Find I_T in polar form. $I_R := \frac{V_{in}}{R} = \frac{10 \cdot \text{V}}{50 \cdot \Omega} \angle_{-36.9} = \frac{10 \cdot \text{V}}{50 \cdot \Omega} \cdot \cos(-36.9 \cdot \text{deg}) + j \cdot \frac{10 \cdot \text{V}}{50 \cdot \Omega} \cdot \sin(-36.9 \cdot \text{deg}) = 160 - 120i \cdot \text{mA}$

$$I_T := I_R + I_Z = (160 - 120j) \cdot \text{mA} + 100 \cdot \text{mA} = 260 - 120j \cdot \text{mA}$$

$$\sqrt{260^2 + 120^2} = 286.356 \quad \text{atan}\left(\frac{-120}{260}\right) = -24.78 \cdot \text{deg} \quad I_T = 286 \text{mA} \angle_{-24.8}$$

- c) Circle 1: i) The source current leads the source voltage answer i), $-24.8^\circ > -36.9^\circ$
 ii) The source voltage leads the source current

d) The impedance Z (above) is made of two components in series. What are they and what are their values?

$$Z = 80 - 60j \cdot \Omega$$

Must have a resistor because there is a real part.

$$R := \text{Re}(Z)$$

$$R = 80 \cdot \Omega$$

Must have a capacitor because the imaginary part is negative.

$$\text{Im}(Z) = -60 \cdot \Omega = \frac{-1}{\omega \cdot C} \quad C := \frac{-1}{\omega \cdot \text{Im}(Z)}$$

$$C = 16.667 \cdot \mu\text{F}$$

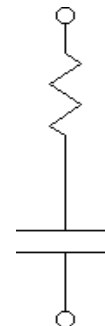

ECE 2210 / 00 Phasor Examples p5

Ex 5. The impedance $Z = 80 - 60j \cdot \Omega$ is made of two components in parallel. What are they and what are their values?

Must have a resistor because there is a real part.

Must have a capacitor because the imaginary part is negative.

$$Z = \frac{1}{\frac{1}{R} + j \cdot \omega \cdot C} \quad \frac{1}{Z} = \frac{1}{(80 - 60j) \cdot \Omega} \cdot \frac{(80 + 60j)}{(80 + 60j)} = \frac{80 + 60j}{80^2 + 60^2} = \frac{80 + 60j}{10,000} \cdot \frac{1}{\Omega}$$

$$\frac{1}{Z} = 0.008 + 0.006j \cdot \Omega^{-1} = \frac{1}{R} + j \cdot \omega \cdot C$$

$$\frac{1}{R} = .008 \cdot \frac{1}{\Omega}$$

$$R := \frac{1}{.008 \cdot \Omega^{-1}}$$

$$R = 125 \cdot \Omega$$

$$\omega \cdot C = .006 \cdot \frac{1}{\Omega}$$

$$C := \frac{.006 \cdot \Omega^{-1}}{\omega}$$

$$C = 6 \cdot \mu\text{F}$$

$$R = 125 \cdot \Omega$$

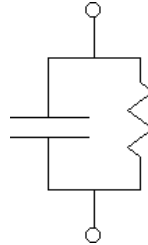

Positive imaginary parts would require inductors

Ex 6. a) Find I_1

$$\omega := 20000 \cdot \frac{\text{rad}}{\text{sec}}$$

$$V_{in} := 20 \cdot \text{V} \cdot e^{j \cdot 30 \cdot \text{deg}}$$

$$I_1 := \frac{V_{in}}{R} = \frac{20 \cdot \text{V}}{250 \cdot \Omega} \cdot e^{j \cdot 30 \cdot \text{deg}} = 80 \cdot \text{mA} \cdot e^{j \cdot 30 \cdot \text{deg}}$$

polar division

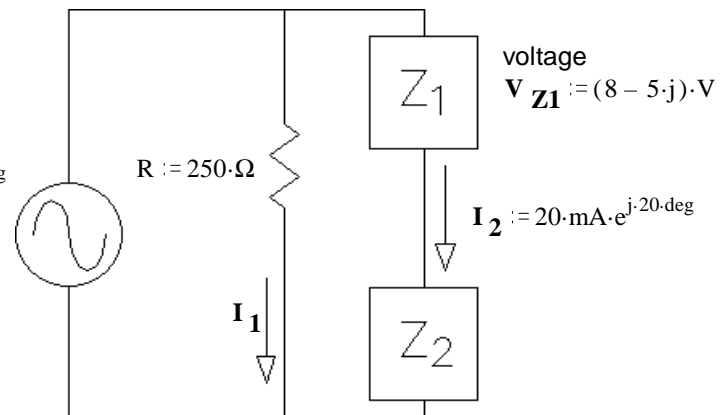

$$\text{voltage } V_{Z1} := (8 - 5j) \cdot \text{V}$$

$$I_2 := 20 \cdot \text{mA} \cdot e^{j \cdot 20 \cdot \text{deg}}$$

b) Circle 1:

i) V_{in} leads I_2

ii) V_{in} lags I_2

Why? Show numbers:

$$\underline{30} > \underline{20}$$

$$\underline{\quad} < \underline{\quad}$$

c) Find Z_2 in polar form

Convert V_{in} to rectangular coordinates

$$20 \cdot \text{V} \cdot \cos(30 \cdot \text{deg}) = 17.321 \cdot \text{V}$$

$$20 \cdot \text{V} \cdot \sin(30 \cdot \text{deg}) = 10 \cdot \text{V}$$

pol to rect

$$V_{in} = 17.321 + 10j \cdot \text{V}$$

$$V_{Z2} := V_{in} - V_{Z1}$$

$$V_{Z2} = 9.321 + 15j \cdot \text{V}$$

subtract

$$\text{rect to pol} \quad \sqrt{9.321^2 + 15^2} = |V_{Z2}| = 17.66 \cdot \text{V}$$

$$\text{atan}\left(\frac{15}{9.321}\right) = \arg(V_{Z2}) = 58.145 \cdot \text{deg}$$

$$\text{div } Z_2 := \frac{V_{Z2}}{I_2} = \frac{17.66 \cdot \text{V}}{20 \cdot \text{mA}} = 883 \cdot \Omega$$

$$\underline{\quad} \cdot 58.145 \cdot \text{deg} - 20 \cdot \text{deg} = 38.145 \cdot \text{deg}$$

$$Z_2 = 883 / 38.15^\circ \Omega$$

$$Z_2 = 694.436 + 545.379j \cdot \Omega$$

Ex 7. You need to design a circuit in which the "output" voltage leads the input voltage ($v_S(t)$) by 40° of phase.

a) What should go in the box: R, L, C?

$$V_o = \frac{Z_{\text{box}}}{R + Z_{\text{box}}} \cdot V_S$$

angle of $\frac{Z_{\text{box}}}{R + Z_{\text{box}}}$ is 40° .

This can only happen if the angle of Z_{box} is positive, so Z_{box} is an inductor

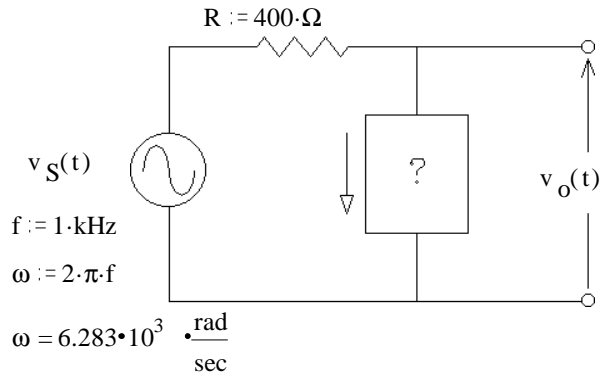

b) Find its value. $V_o = \frac{j \cdot \omega \cdot L}{R + j \cdot \omega \cdot L} \cdot V_S$ angle $\frac{j \cdot \omega \cdot L}{R + j \cdot \omega \cdot L}$ is $90 - \text{atan}\left(\frac{\omega \cdot L}{R}\right) = 40^\circ$.

So: $\text{atan}\left(\frac{\omega \cdot L}{R}\right) = 50^\circ$ $\frac{\omega \cdot L}{R} = \tan(50 \cdot \text{deg}) = 1.192$ $L = \frac{R \cdot 1.192}{\omega} = 75.9 \cdot \text{mH}$

c) Repeat if the "output" voltage should lag the input voltage ($v_S(t)$) by 20° of phase.

angle of $\frac{Z_{\text{box}}}{R + Z_{\text{box}}}$ is -20° . This can only happen if the angle of Z_{box} is negative, so Z_{box} is a capacitor

$$V_o = \frac{1}{R + \frac{1}{j \cdot \omega \cdot C}} \cdot V_S \quad \text{angle} \quad \frac{1}{R + \frac{1}{j \cdot \omega \cdot C}} \quad \text{is} \quad -90 - \text{atan}\left(\frac{1}{\omega \cdot C \cdot R}\right) = -90 - \text{atan}\left(-\frac{1}{\omega \cdot C \cdot R}\right)$$

$\text{atan}\left(-\frac{1}{\omega \cdot C \cdot R}\right) = -70^\circ$ $-\frac{1}{\omega \cdot C \cdot R} = \tan(-70 \cdot \text{deg}) = -2.747$ $C = \frac{1}{\omega \cdot R \cdot 2.747} = 0.145 \cdot \mu\text{F}$

Ex 8. Find V_o in the circuit shown. Express it as a magnitude and phase angle (polar).

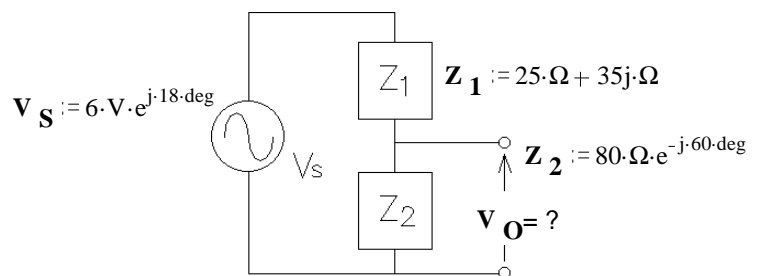

$V_o := \frac{Z_2}{Z_1 + Z_2} \cdot V_S$ Simple voltage divider

$|Z_2| \cdot \cos(-60 \cdot \text{deg}) = 40 \cdot \Omega$ $|Z_2| \cdot \sin(-60 \cdot \text{deg}) = -69.282 \cdot \Omega$ $Z_2 = 40 - 69.282j \cdot \Omega$

$Z_1 + Z_2 = 25 \cdot \Omega + 35j \cdot \Omega + 40 \cdot \Omega - 69.282j \cdot \Omega = 65 - 34.282j \cdot \Omega = 73.486 \cdot \Omega \cdot e^{-j \cdot 27.81 \cdot \text{deg}}$

$V_o := \frac{Z_2}{Z_1 + Z_2} \cdot V_S = \frac{80 \cdot \Omega \cdot e^{-j \cdot 60 \cdot \text{deg}}}{73.486 \cdot \Omega \cdot e^{-j \cdot 27.81 \cdot \text{deg}}} \cdot (6 \cdot \text{V} \cdot e^{j \cdot 18 \cdot \text{deg}}) = \frac{80 \cdot \Omega}{73.486 \cdot \Omega} \cdot 6 \cdot \text{V} \cdot e^{j \cdot (-60 - (-27.81) + 18) \cdot \text{deg}} = 6.53 \cdot \text{V} \cdot e^{-j \cdot 14.2 \cdot \text{deg}}$

Read about complex numbers and phasors in your textbook (sections 2.26 & 2.27, starting on p.159).

1. For the complex numbers $z_1 := -4 + 5j$ and $z_2 := 2 + 4j$ Determine the following

a) Does $|z_1 \cdot z_2|$ equal $|z_1| \cdot |z_2|$?

b) Does $\left| \frac{z_1}{z_2} \right|$ equal $\frac{|z_1|}{|z_2|}$?

c) Does $|z_1 + z_2|$ equal $|z_1| + |z_2|$?

2. a) Find the phasor for $v(t) = 8.4 \cdot \cos(100t - 90\text{-deg})$ Express in both forms, polar and rectangular.

b) The phasor representation of a current is $I := (5 + j \cdot 12) \cdot \mu\text{A}$ Find the time-domain representation, $i(t)$. $f := 600\text{-Hz}$

3. Add or subtract the sinusoidal voltages using phasors. Draw a phasor diagram which shows all 3 phasors, and give your final answer in time domain form.

a) $v_1(t) = 1.5 \cdot V \cdot \cos(\omega t + 10\text{-deg})$ $v_2(t) = 3.2 \cdot V \cdot \cos(\omega t + 25\text{-deg})$ Find $v_3(t) = v_1(t) + v_2(t)$

b) $v_1(t) = 1.5 \cdot V \cdot \cos(\omega t + 10\text{-deg})$ $v_2(t) = 3.2 \cdot V \cdot \cos(\omega t + 25\text{-deg})$ Find $v_4(t) = v_1(t) - v_2(t)$

you may add V_4 to the phasor diagram you've already drawn for part a).

c) $v_1(t) = 50 \cdot V \cdot \cos(\omega t - 60\text{-deg})$ $v_2(t) = 24 \cdot V \cdot \cos(\omega t + 15\text{-deg})$ Find $v_3(t) = v_1(t) + v_2(t)$

d) $v_1(t) = 0.9 \cdot V \cdot \cos(\omega t + 72\text{-deg})$ $v_2(t) = 1.2 \cdot V \cdot \cos(\omega t - 20\text{-deg})$ Find $v_3(t) = v_1(t) + v_2(t)$

e) $v_1(t) = 0.9 \cdot V \cdot \cos(\omega t + 72\text{-deg})$ $v_2(t) = 1.2 \cdot V \cdot \cos(\omega t - 20\text{-deg})$ Find $v_4(t) = v_2(t) - v_1(t)$

you may add V_4 to the phasor diagram you've already drawn for part d).

4. Express the impedance of a 5.2mH inductor at 60 Hz in polar form.

5. a) A capacitor impedance has a magnitude of 240Ω at a frequency of 1.8kHz. What is the value of capacitor?

b) What value inductor has the same impedance magnitude at the same frequency?

c) Find the reactance (magnitude of the impedance with + or - sign) of this capacitor and this inductor at 3.6kHz?

d) What would be the total impedance of this inductance and this capacitance connected in series at 2.7kHz?

6. Find Z_{eq} in each case.

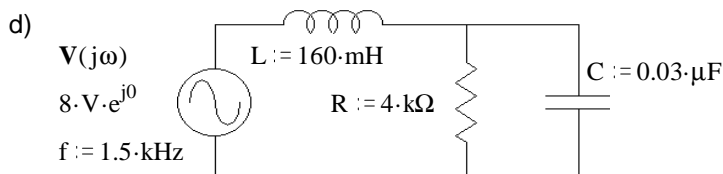
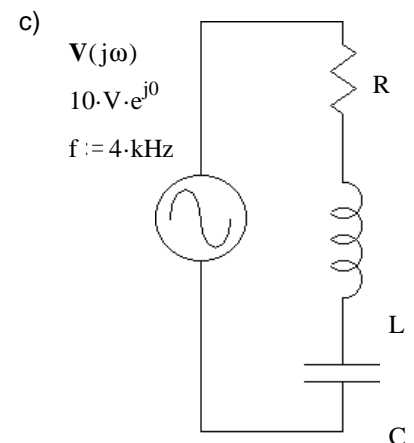
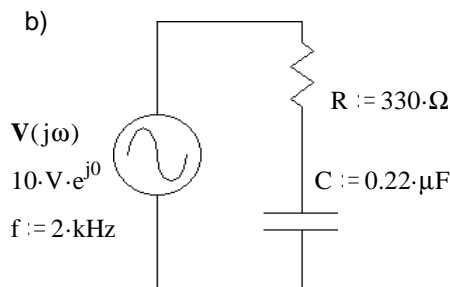
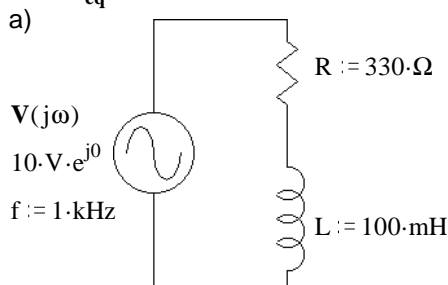

7. Find the current $I(j\omega)$ in each case above.

8. a) Find Z . Hint: Find the total impedance ($R+Z$) first.

b) Which leads, current or voltage?

c) By how much?

I.E. what is the phase angle between the voltage and current?

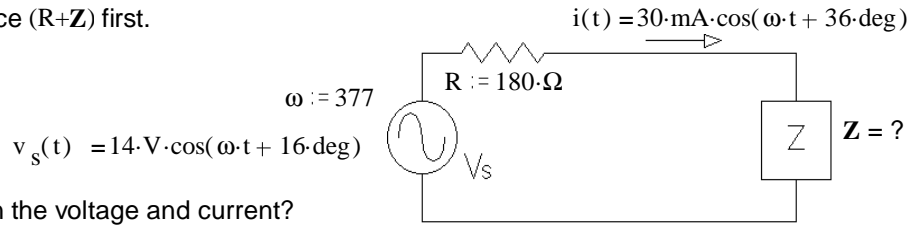

9. a) A resistor and a capacitor are connected in series to create an impedance of $Z := 50 \cdot \Omega \cdot e^{-j \cdot 66 \cdot \text{deg}} = 50 \Omega / -66^\circ$ at a frequency $f := 3 \cdot \text{kHz}$. Find R and C.

b) A resistor and a capacitor are connected in parallel to create an impedance of $Z := 50 \cdot \Omega \cdot e^{-j \cdot 66 \cdot \text{deg}} = 50 \Omega / -66^\circ$ at a frequency $f := 3 \cdot \text{kHz}$. Find R and C.

Hint: invert Z_{eq} , Instead of solving this: $50 / -66 \text{deg} = \frac{1}{\frac{1}{R} + j \cdot \omega \cdot C}$

solve this: $\frac{1}{Z_{eq}} = 0.02 / 66 \text{deg} = \frac{1}{R} + j \cdot \omega \cdot C$

10. The phasor diagram at right shows the voltage and current in the circuit below

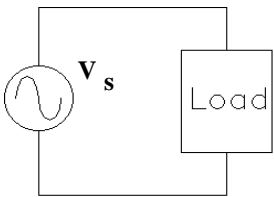

Assume the load consists of a resistor in series with a reactive component and the frequency is 60 Hz.

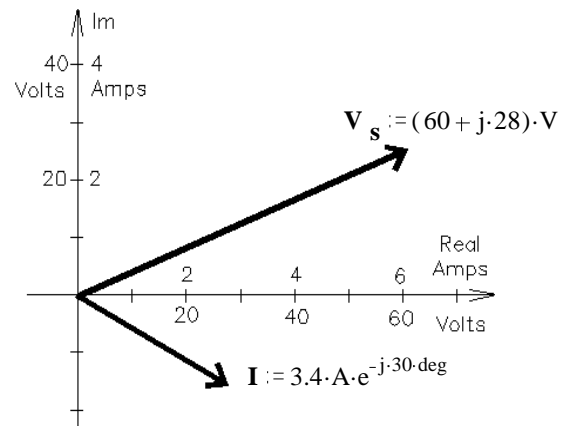

a) What is the magnitude of the impedance?

b) What is the value of the resistor?

c) What is the reactive component (type and value)?

11. For the circuit shown, draw a phasor diagram showing V_S , I , V_R , and V_C . Draw the voltages to scale so that you can show that they obey KVL.

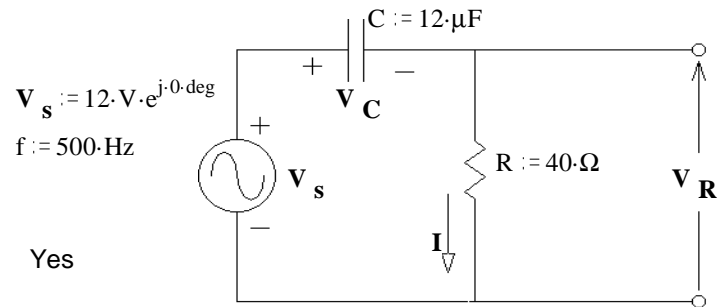

Answers

1. a) $28.636 = 28.636$ Yes b) $1.432 = 1.432$ Yes
c) $9.22 \text{ not} = 10.875$ No

2. a) $8.4 / -90^\circ = 8.4 \cdot e^{-j \cdot 90 \cdot \text{deg}} = -8.4j$ b) $13 \cdot \mu\text{A} \cdot \cos(3770 \cdot t + 67.4 \cdot \text{deg})$

3. a) $v_1(t) + v_2(t) = 4.67 \cdot \cos(\omega \cdot t + 20.2 \cdot \text{deg}) \cdot \text{V}$

b) $v_1(t) - v_2(t) = 1.794 \cdot \cos(\omega \cdot t - 142.5 \cdot \text{deg}) \cdot \text{V}$

d) $v_1(t) + v_2(t) = 1.48 \cdot \cos(\omega \cdot t + 17.6 \cdot \text{deg}) \cdot \text{V}$

c) $v_1(t) + v_2(t) = 60.8 \cdot \cos(\omega \cdot t - 37.6 \cdot \text{deg}) \cdot \text{V}$

e) $v_2(t) - v_1(t) = 1.525 \cdot \cos(\omega \cdot t - 56.15 \cdot \text{deg}) \cdot \text{V}$

4. $1.96 \Omega / 90^\circ$ 5. a) $0.368 \cdot \mu\text{F}$ b) $21.2 \cdot \text{mH}$

c) $-120 \cdot \Omega$ $480 \cdot \Omega$ d) $200 \cdot j \cdot \Omega$

6. a) $(330 + 628.3 \cdot j) \cdot \Omega = 709.7 \Omega / 62.29^\circ$

b) $(330 - 361.7 \cdot j) \cdot \Omega = 489.6 \Omega / -47.63^\circ$

7. a) $(6.6 - 12.5 \cdot j) \cdot \text{mA} = 14.1 \text{mA} / -62.29^\circ$

b) $(13.8 + 15.1 \cdot j) \cdot \text{mA} = 20.4 \text{mA} / 47.63^\circ$

d) $4.4 \text{mA} / 15.2^\circ$

c) $R + \left(\omega \cdot L - \frac{1}{\omega \cdot C} \right) \cdot j$

d) $1.82 \text{k}\Omega / -15.2^\circ$

c) $\frac{10 \cdot \text{V}}{\sqrt{R^2 + \left(\omega \cdot L - \frac{1}{\omega \cdot C} \right)^2}}$

8. a) $259 - 160 \cdot j$ b) The current leads the voltage c) 20°

9. a) $20.34 \cdot \Omega$ $1.16 \cdot \mu\text{F}$ b) $123 \cdot \Omega$ $0.969 \cdot \mu\text{F}$

10. a) $19.5 \cdot \Omega$ b) $11.2 \cdot \Omega$ c) inductor $42.3 \cdot \text{mH}$

ECE 2210/00 homework # 12 p.2

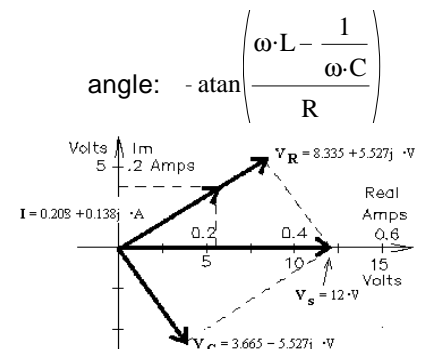

11.

The 2nd exam will include this material

Warning: This homework is longer than normal -- DO NOT put it off until the last minute.

1. For the circuit shown, find the following:

- a) At what frequency would the magnitude of the total impedance be 240Ω ?
- b) At this frequency, what is the phase angle of the impedance?
- c) At this frequency, you want to add a capacitor in series to make the circuit appear purely resistive (the impedance has no imaginary component). Find the value of the capacitor.

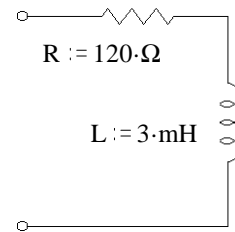

2. You need to design a circuit in which the current $i(t)$ leads the voltage $v_S(t)$ by 36° of phase.

- a) What should go in the box: R, L, C?
- b) Find its value.

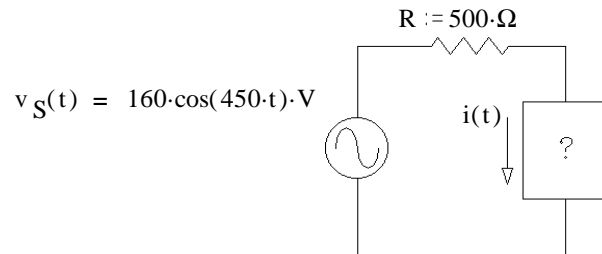

3. The phasor diagram at right shows the source voltage and two branch currents of a parallel circuit. Find the impedance of each of the two branches.

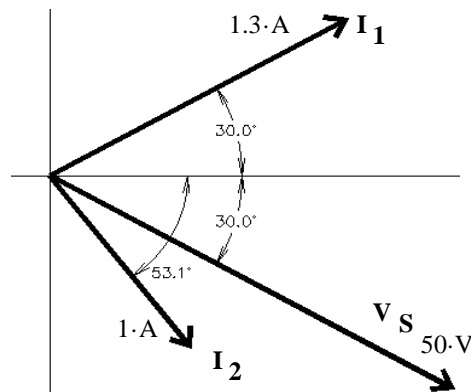
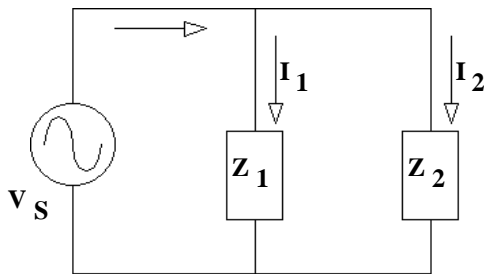

4. a) Find all the currents, I_1 , I_2 , and I_T .

$v_S := 24 \text{ V} \cdot e^{j \cdot 45 \text{ deg}}$

b) Draw a phasor diagram showing I_1 , I_2 , and I_T to scale so that you can show that they obey KCL.

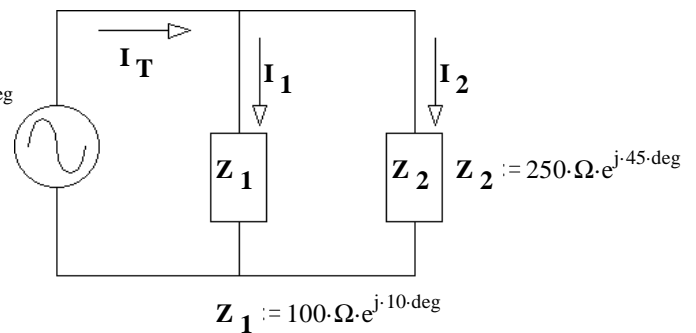

5. a) Find the AC current source, I_{in} in polar form.

b) Find V_T .

c) Choose one:

- i) The source current leads the source voltage.
- ii) The source current lags the source voltage.

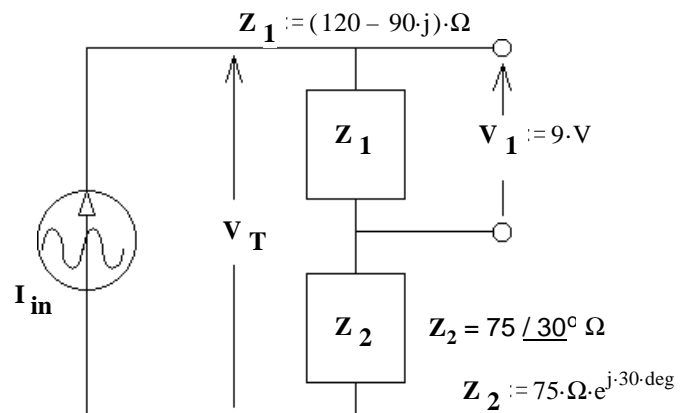

ECE 2210 homework # 13 p.2

6. a) Find Z_1 .

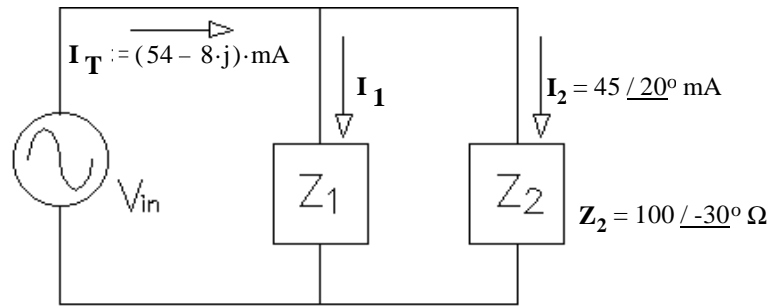

b) To make Z_1 in the simplest way, what part(s) would you need? Just determine the needed part(s) from the list below and state why you made that choice, don't find the values.

- | | | | | |
|-------------------|-------------------|-----------|--------------|----------------|
| resistor | capacitor | inductor | power supply | current source |
| Thevenin resistor | Ideal transformer | voltmeter | ammeter | scope |

- c) Choose one: i) I_2 leads the source voltage (V_{in}) ii) I_2 lags the source voltage (V_{in})
- d) Choose one: i) I_1 leads I_2 ii) I_1 lags I_2

7. Find Z .

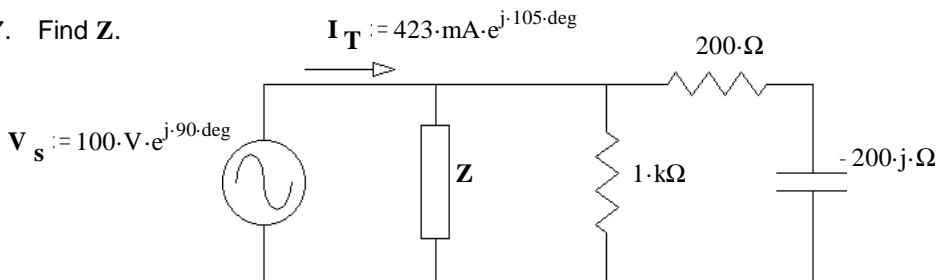

8. a) Find the total impedance of the circuit.

b) Find I_T .

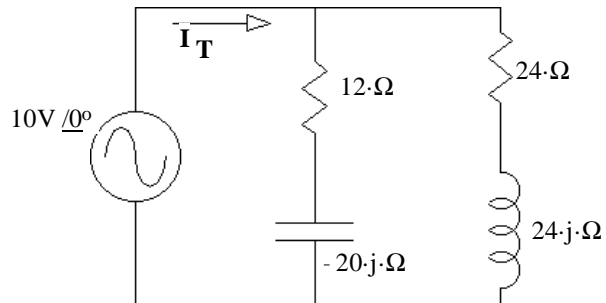

9. Find Z_{eq} in simple polar form.

$f := 8000\text{-Hz}$

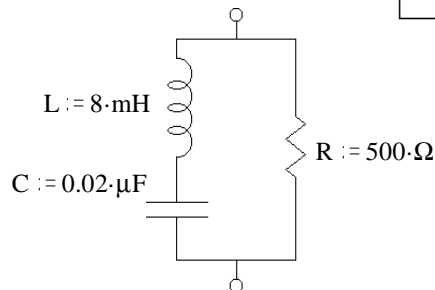

Answers

1. a) 11-kHz b) 60° c) 0.0694-μF
2. a) C b) 6.12-μF
3. $Z_1 = (19.2 - 33.3j) \cdot \Omega$ $Z_2 = (46.0 + 19.6j) \cdot \Omega$
4. a) $(0.197 + 0.138j) \cdot A + 0.096 \cdot A = 0.293 + 0.138j \cdot A$
5. a) $60 / 36.87^\circ \text{ mA}$ b) $11.54 / 21^\circ \text{ V}$ c) i)
6. a) $172 / 53.4^\circ \Omega$ b) phase angle > 0, resistor and inductor
- c) i) d) ii)
7. $657 \Omega / 67.4^\circ$ 8. a) $21.86 \Omega / -20.38^\circ$ b) $0.457 A / 20.38^\circ$
9. $382 \Omega / -40.2^\circ$

