

ECE 2200/10 Lecture 1 Introduction to Electrical Engineering for non-majors

A. Stolp
12/30/11
8/24/15

2200 = 1/2 semester (Mining, Mat. Sci.)

ECE 2200 Without the Physics is hard, Plan on it!

2200, Decide today when you want to take the **final**:
Final is day after official end of class unless you ask for
different accomodation today.

Make sure you are
registered for the right class
(2200 or 2210) and that you
have the right syllabus.

2210 = Full semester (Mechanical, Chemical, etc.)

2210 Final Monday, May 3, 8:00am

BOTH

Regularly check the calendar on for this class on Canvas. Watch your Canvas announcements.
Be prepared to download and watch videos and download and print homeworks.

Homeworks are due by 11:59 pm of the due date on Canvas.

Make sure you have a way to scan your paper or do your work on a tablet so that you will can submit a .pdf file

WARNING: HWs are often due on non-class days.

Labs start next week. May need a lab notebook and a U-card with \$20 for labs at some future time, NOT NOW.



How to survive

1. Easiest way to get through school is to actually learn and retain what you are asked to learn.
Even if you're too busy, don't lose your good study practices.
What you "just get by" on today will cost you later.

Don't fall for the "I'll never need to know this" trap. Sure, much of what you learn you may not use, but you will need some of it, some day, either in the current class, future classes, or maybe sometime in your career. Don't waste time second-guessing the curriculum, It'll still be easier to just do your best to learn and retain what is covered.

2. Don't fall for the "traps".
Homework answers, Problem session solutions, Posted solutions, Lecture notes.
3. KEEP UP! Use calendar.
4. Make "permanent notes" after you've finished a subject or section and feel that you know it.

Lecture

<u>Basic electrical quantities</u>	<u>Letter used</u>	<u>Units</u>	<u>Fluid Analogy</u>
Charge, actually moves	Q	Coulomb (C)	m^3
Current, like fluid flow	$I = \frac{Q}{\text{sec}}$	Amp (A, mA, μA ,...)	$\frac{m^3}{\text{sec}}$
Voltage, like pressure	V or E	volt (V, mV, kV,...)	$\text{Pa} = 1 \cdot \frac{N}{m^2}$
Resistance 	$R = \frac{V}{I}$	Ohm (Ω , k Ω , M Ω ,...)	
Conductance 	$G = \frac{1}{R}$	Siemens (S, also mho, old unit)	
Power = energy/time	$P = V \cdot I$	Watt (W, mW, kW, MW,...)	W

Symbols (ideal)

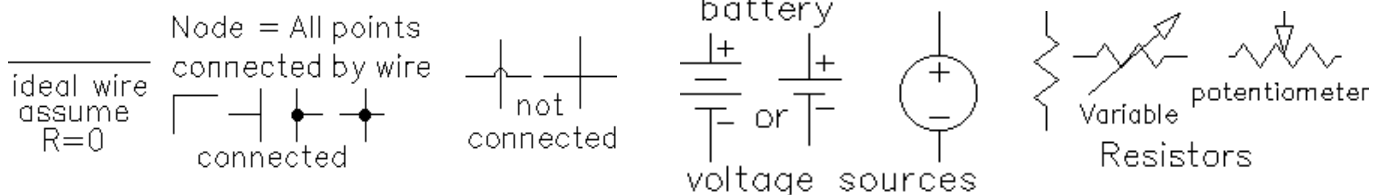

ECE 2210 Lecture 1 notes p2

KCL, Kirchhoff's Current Law

$I_{in} = I_{out}$ of any point, part, or section

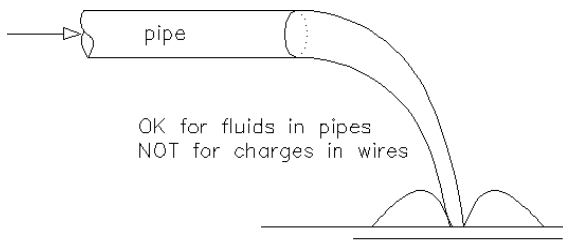
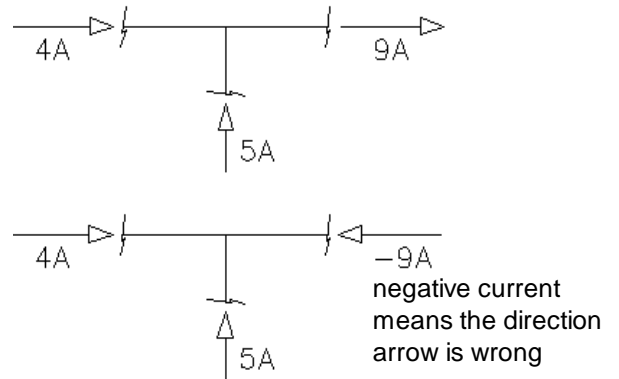
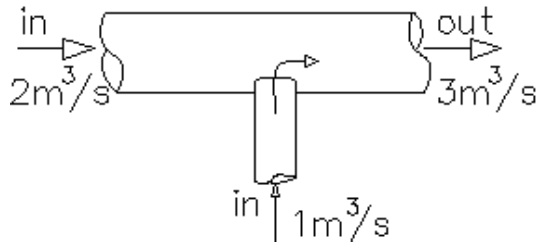
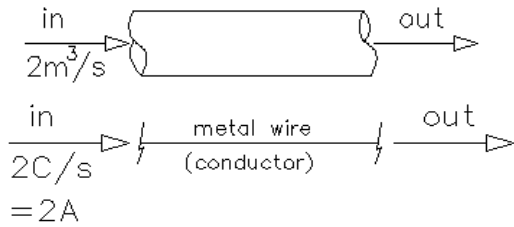
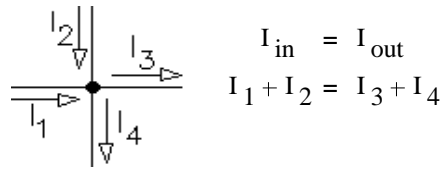

Conductors Nonconductors
 Massless fluid in our analogy
 No gravity effects No Bernoulli effects

Reasonable because:

- Electron mass is $9.11 \cdot 10^{-31} \cdot \text{kg}$
- Electron charge is $-1.6 \cdot 10^{-16} \cdot \text{C}$
- Negative charge flows in negative direction

Battery also obeys KCL
 No accumulation of charge anywhere,
 so it must circulate around.
 Leads to the concept of a "Circuit"

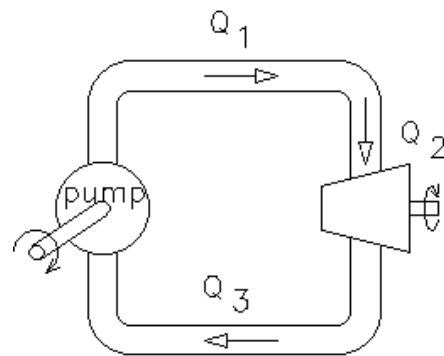
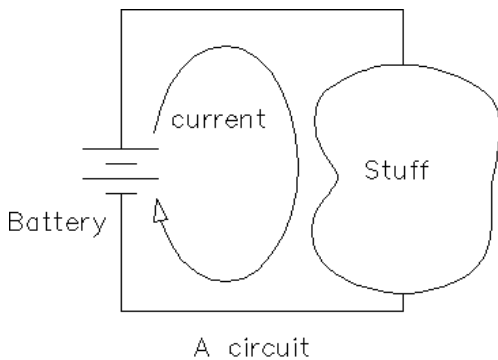

Voltage is like pressure
KVL, Kirchhoff's Voltage Law

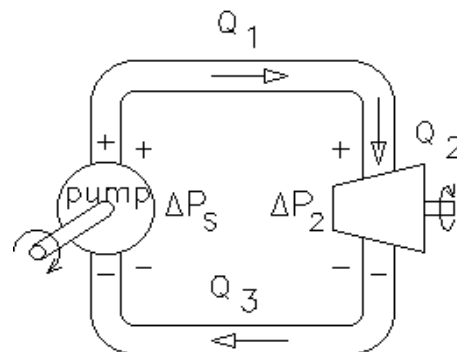
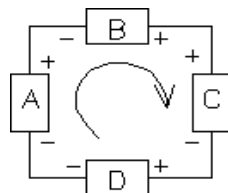
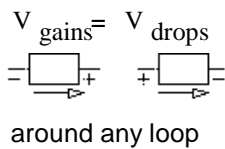

Ohm's law (resistors)

$$V = I \cdot R$$

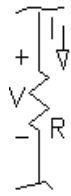

$$I = \frac{V}{R}$$

$$R = \frac{V}{I}$$

definition of resistance and the unit " Ω "

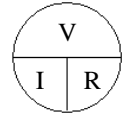

Power

flow $\frac{m^3}{sec}$ pressure $\frac{N}{m^3}$ flow x pressure: $\frac{m^3}{sec} \cdot \frac{N}{m^3} = \frac{m \cdot N}{sec \cdot 1} = \frac{N \cdot m}{sec} = \frac{Joule}{sec} = W = power$

same for electricity power $P = I \cdot V$

Power dissipated by resistors: $P = V \cdot I = \frac{V^2}{R} = I^2 \cdot R$

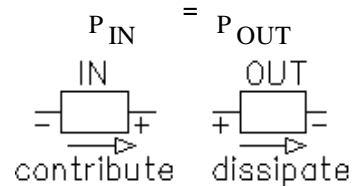

Series Resistors

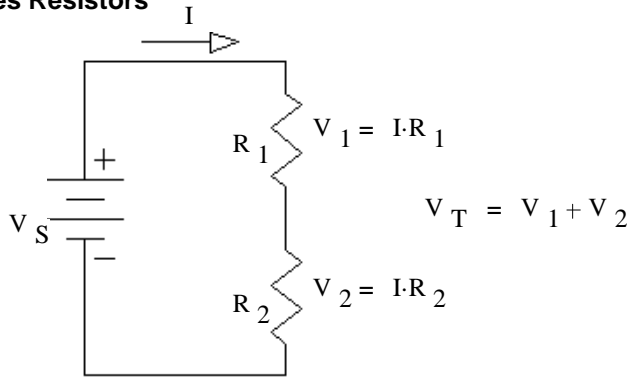

$$R_{eq} = \frac{V_T}{I} = \frac{V_1 + V_2}{I} = \frac{V_1}{I} + \frac{V_2}{I} = R_1 + R_2$$

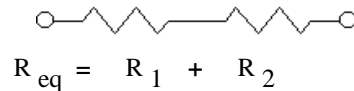

Resistors are in series if and only if exactly the **same current** flows through each resistor.

Parallel Resistors

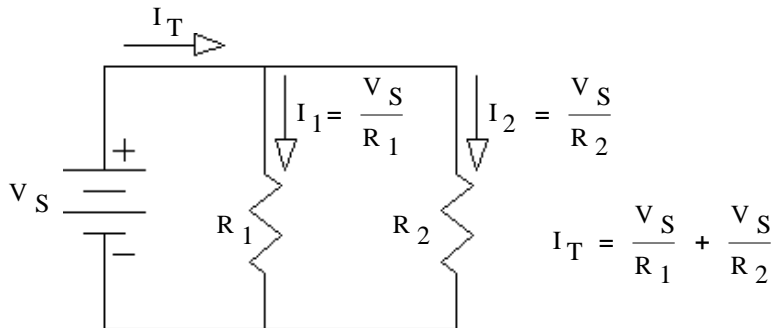

$$R_{eq} = \frac{V_S}{I_T} = \frac{V_S}{\frac{V_S}{R_1} + \frac{V_S}{R_2}} = \frac{1}{\frac{1}{R_1} + \frac{1}{R_2}}$$

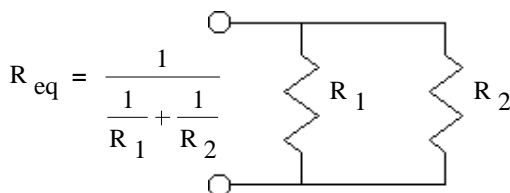

Resistors are in parallel if and only if the **same voltage** is across each resistor.

Series and Parallel

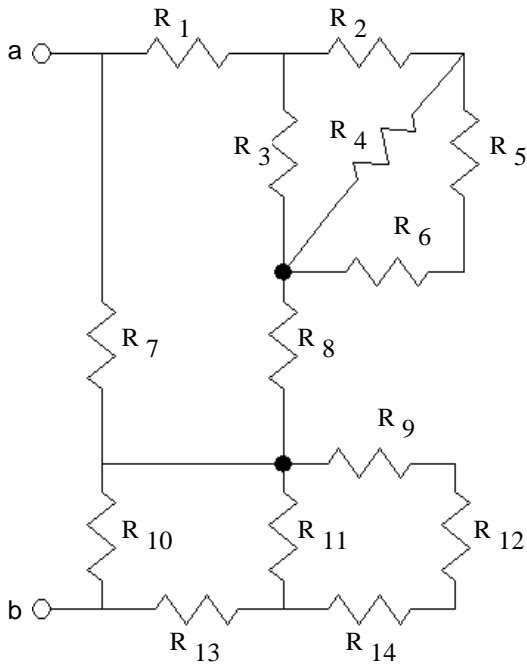

All resistor-only networks can be reduced to a single equivalent, but not always by means of series and parallel concepts.

Voltage Divider

series: $R_{eq} = R_1 + R_2 + R_3 + \dots$

Exactly the **same current** through each resistor

Voltage divider:

$$V_{Rn} = V_{total} \cdot \frac{R_n}{R_1 + R_2 + R_3 + \dots}$$

Current Divider

parallel: $R_{eq} = \frac{1}{\frac{1}{R_1} + \frac{1}{R_2} + \frac{1}{R_3} + \dots}$

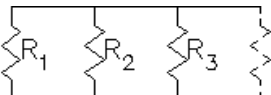

Exactly the **same voltage** across each resistor

current divider:

$$I_{Rn} = I_{total} \cdot \frac{\frac{1}{R_n}}{\frac{1}{R_1} + \frac{1}{R_2} + \frac{1}{R_3} + \dots}$$

May have to combine some resistors first to get series and parallel resistors to use with divider expressions.

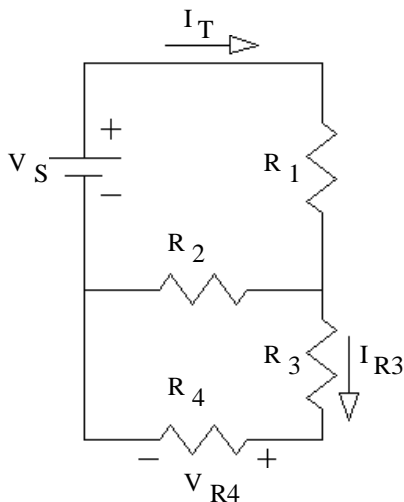

$V_{R4} =$

$I_T =$

$I_{R3} =$

Resistors

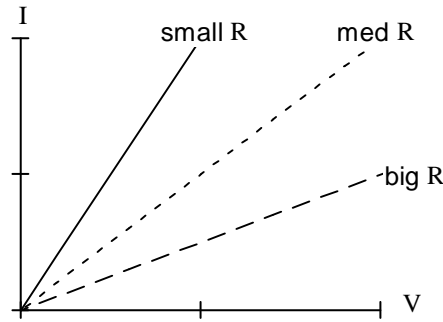
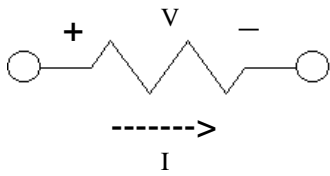

$$R = \frac{1}{\text{slope}} = \frac{\Delta V}{\Delta I}$$

Sources

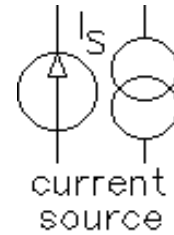
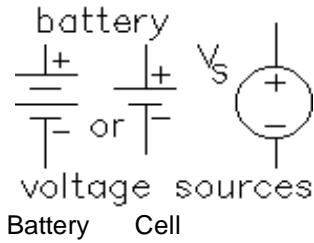

Less intuitive, less like sources we are used to seeing.

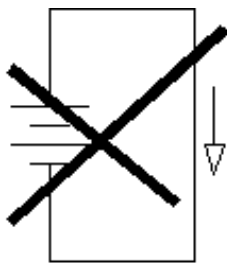
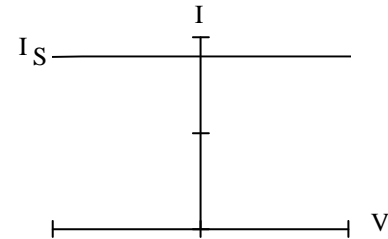
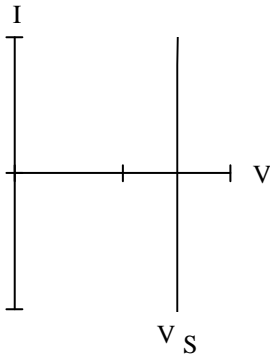

Doesn't make sense with for ideal voltage sources and ideal wires

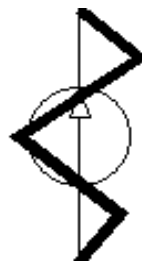

Doesn't make sense for ideal current sources

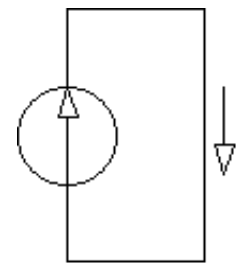

Must have a path for the current to flow

Ground

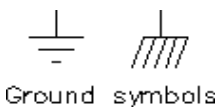

Ground symbols

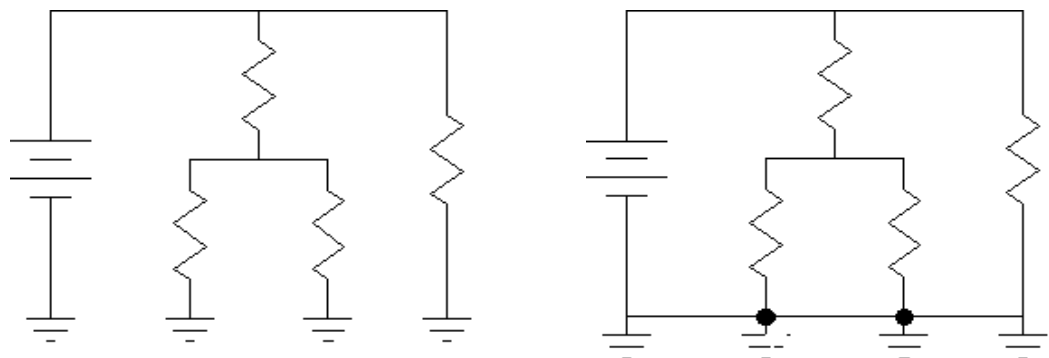

Ground is considered zero volts and is a reference for other voltages.

Node = all points connected by wire, all at same voltage (potential)

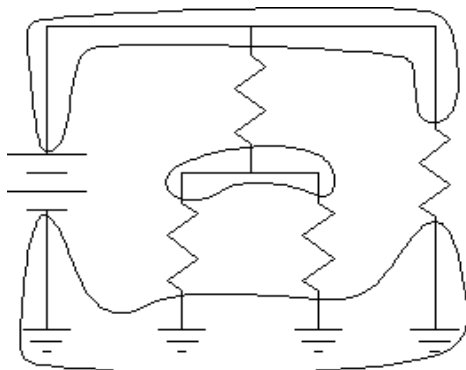

ground is a node

Branch = all parts with the same current

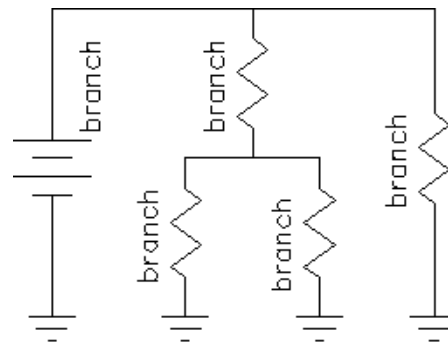

Meters

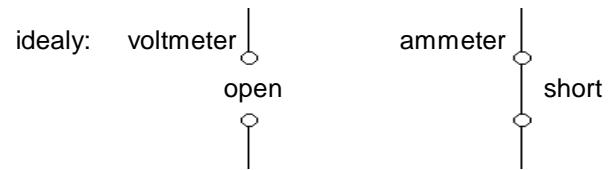
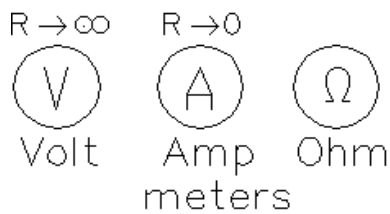

Analog meters

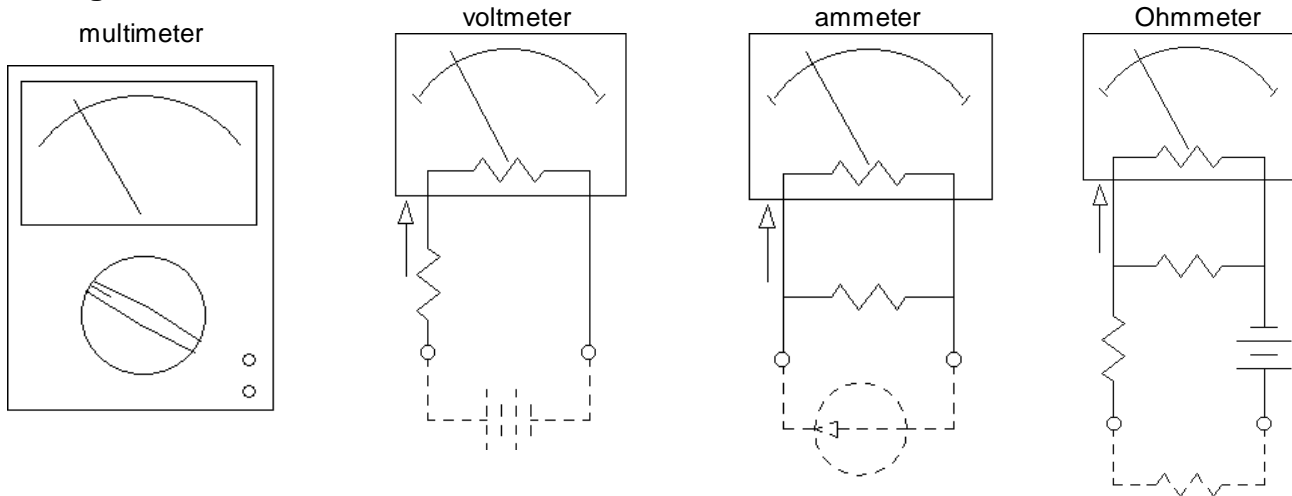

Digital meter

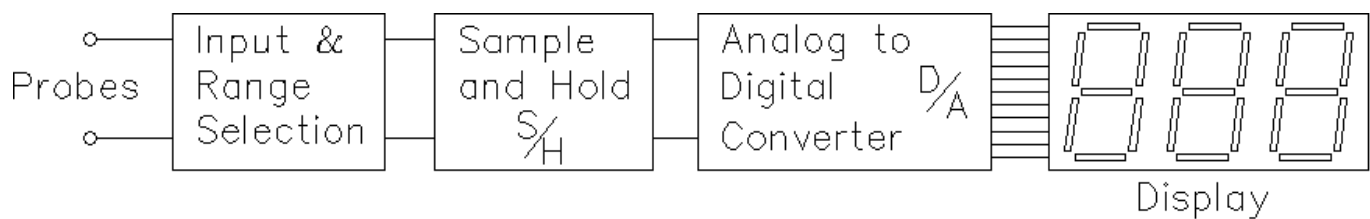

Scan your homework and convert to a pdf file. Turn in on Canvas. Homework is due by 11:59 p.m. on the due date.

The following problems are not meant to be hard. You should be able to do most of them in your head with no special formulas or calculations. In fact you should find them rather dumb and trivial. That's the point, I want to drill these concepts into your head so that you'll find them easy.

1. The figure at right shows a hydraulic system with a pump that converts rotational energy to fluid energy and two turbines which convert that energy back to rotational energy. Do NOT assume that the turbines are equal in size. This is a closed system containing an incompressible fluid with no places for that fluid to collect; i.e. flow in = flow out of any point or object. Kirchhoff's current law applies. The volumetric fluid flows are indicated by the arrows.

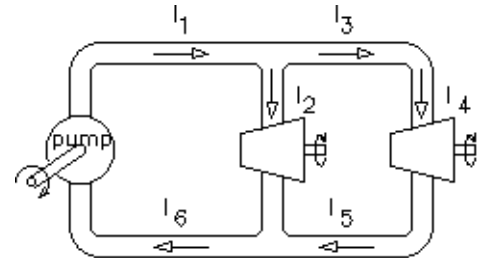

$$I_1 := 0.01 \frac{\text{m}^3}{\text{s}} \quad I_2 := 0.007 \frac{\text{m}^3}{\text{s}}$$

$$I_3 = \underline{\hspace{2cm}} \quad I_4 = \underline{\hspace{2cm}} \quad I_5 = \underline{\hspace{2cm}} \quad I_6 = \underline{\hspace{2cm}}$$

2. The figure at right shows an electrical circuit with a battery that converts chemical energy to electrical energy and two resistors which convert that electrical energy to heat energy. Do NOT assume that the resistors are equal in size. All electrical circuits are closed systems containing incompressible charges with no places for those charges to collect; i.e. flow in = flow out of any point or object. Kirchhoff's current law applies. The electrical currents are indicated by the arrows.

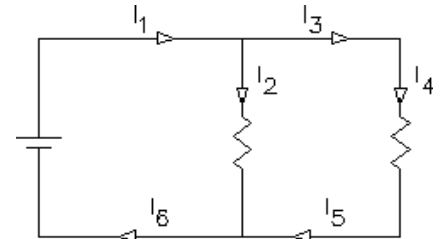

$$I_1 := 0.01 \cdot \text{A} \quad I_2 := 0.007 \cdot \text{A}$$

$$I_3 = \underline{\hspace{2cm}} \quad I_4 = \underline{\hspace{2cm}} \quad I_5 = \underline{\hspace{2cm}} \quad I_6 = \underline{\hspace{2cm}}$$

3. The figure at right shows a similar electrical circuit only now the electrical currents are indicated by the arrows next to the wires. This is a more common way to show the current flow because a little arrow in the wire is too easily confused with the electrical symbol for a diode. You'll learn about diodes later.

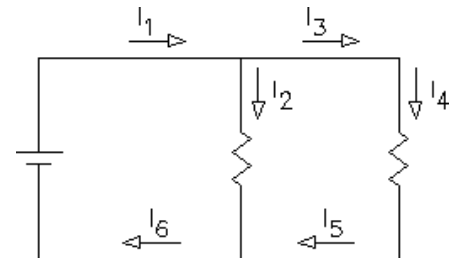

$$I_2 := 20 \cdot \text{mA} \quad I_5 := 14 \cdot \text{mA}$$

$$I_6 = \underline{\hspace{2cm}} \quad I_1 = \underline{\hspace{2cm}} \quad I_3 = \underline{\hspace{2cm}} \quad I_4 = \underline{\hspace{2cm}}$$

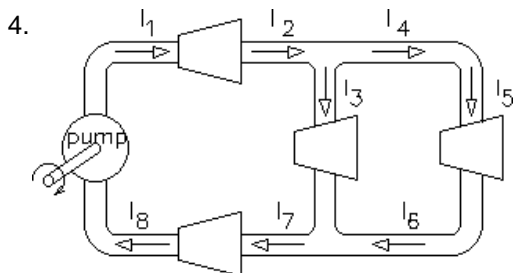

$$I_3 := 0.004 \frac{\text{m}^3}{\text{s}} \quad I_5 := 0.001 \frac{\text{m}^3}{\text{s}} \quad I_4 = \underline{\hspace{2cm}}$$

$$I_2 = \underline{\hspace{2cm}} \quad I_1 = \underline{\hspace{2cm}} \quad I_6 = \underline{\hspace{2cm}}$$

$$I_7 = \underline{\hspace{2cm}} \quad I_8 = \underline{\hspace{2cm}}$$

ECE 2210 / 00 homework # 1, p.2

5. $I_3 := 4.5 \cdot \text{mA}$ $I_5 := 1.2 \cdot \text{mA}$ $I_4 = \underline{\hspace{2cm}}$
 $I_2 = \underline{\hspace{2cm}}$ $I_1 = \underline{\hspace{2cm}}$ $I_6 = \underline{\hspace{2cm}}$
 $I_7 = \underline{\hspace{2cm}}$ $I_8 = \underline{\hspace{2cm}}$

6. Again, a similar electrical circuit with the electrical current arrows in the more common position, next to the wires.

$I_6 := 0.03 \cdot \text{A}$ $I_7 := 0.08 \cdot \text{A}$ $I_8 = \underline{\hspace{2cm}}$
 $I_1 = \underline{\hspace{2cm}}$ $I_2 = \underline{\hspace{2cm}}$ $I_3 = \underline{\hspace{2cm}}$
 $I_4 = \underline{\hspace{2cm}}$ $I_5 = \underline{\hspace{2cm}}$

7. $I_9 := 0.04 \cdot \frac{\text{m}^3}{\text{s}}$ $I_1 = \underline{\hspace{2cm}}$ $I_2 = \underline{\hspace{2cm}}$
 $I_3 = \underline{\hspace{2cm}}$ $I_4 = \underline{\hspace{2cm}}$ $I_5 = \underline{\hspace{2cm}}$
 $I_6 = \underline{\hspace{2cm}}$ $I_7 = \underline{\hspace{2cm}}$ $I_8 = \underline{\hspace{2cm}}$ $I_7 = \underline{\hspace{2cm}}$ $I_{10} = \underline{\hspace{2cm}}$

8. $I_9 := 0.06 \cdot \text{A}$ $I_1 = \underline{\hspace{2cm}}$ $I_2 = \underline{\hspace{2cm}}$
 $I_3 = \underline{\hspace{2cm}}$ $I_4 = \underline{\hspace{2cm}}$ $I_5 = \underline{\hspace{2cm}}$
 $I_6 = \underline{\hspace{2cm}}$ $I_7 = \underline{\hspace{2cm}}$ $I_8 = \underline{\hspace{2cm}}$ $I_7 = \underline{\hspace{2cm}}$ $I_{10} = \underline{\hspace{2cm}}$

9. $I_4 := 0.05 \cdot \frac{\text{m}^3}{\text{s}}$ $I_5 := 0.014 \cdot \frac{\text{m}^3}{\text{s}}$ $I_6 := 0.03 \cdot \frac{\text{m}^3}{\text{s}}$
 $I_1 = \underline{\hspace{2cm}}$ $I_2 = \underline{\hspace{2cm}}$
 $I_3 = \underline{\hspace{2cm}}$ $I_7 = \underline{\hspace{2cm}}$

ECE 2210 / 00 homework # 1, p.3

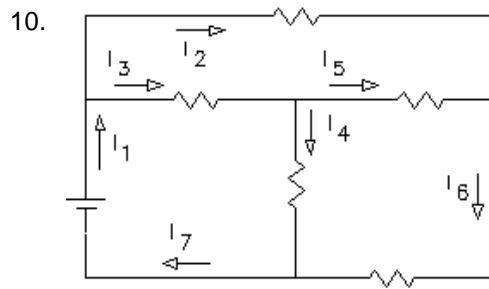

$$I_4 := 20 \cdot \text{mA} \quad I_5 := 10 \cdot \text{mA} \quad I_6 := 22 \cdot \text{mA}$$

$$I_1 = \underline{\hspace{2cm}} \quad I_2 = \underline{\hspace{2cm}}$$

$$I_3 = \underline{\hspace{2cm}} \quad I_7 = \underline{\hspace{2cm}}$$

11. Careful here, there are now two pumps. Also, given the flow arrows shown, one or more of the flows must come out **negative**.

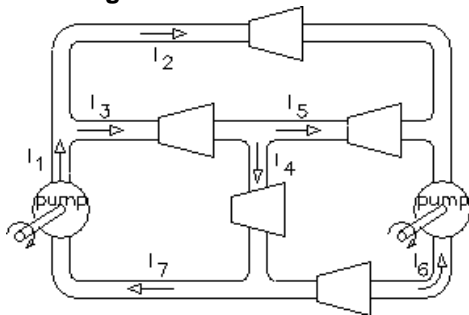

$$I_2 := 0.005 \cdot \frac{\text{m}^3}{\text{s}} \quad I_6 := 0.03 \cdot \frac{\text{m}^3}{\text{s}} \quad I_7 := 0.015 \cdot \frac{\text{m}^3}{\text{s}}$$

$$I_1 = \underline{\hspace{2cm}} \quad I_3 = \underline{\hspace{2cm}}$$

$$I_4 = \underline{\hspace{2cm}} \quad I_5 = \underline{\hspace{2cm}}$$

12. What does a negative fluid flow physically mean?

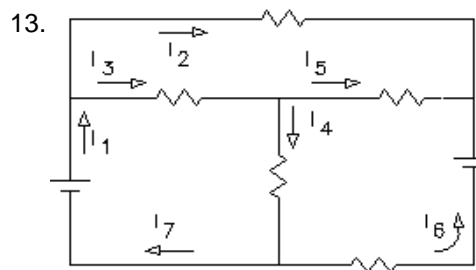

$$I_1 := 0.01 \cdot \text{A} \quad I_5 := -20 \cdot \text{mA} \quad I_6 := 35 \cdot \text{mA}$$

$$I_2 = \underline{\hspace{2cm}} \quad I_3 = \underline{\hspace{2cm}}$$

$$I_4 = \underline{\hspace{2cm}} \quad I_7 = \underline{\hspace{2cm}}$$

14. What does a negative electrical current physically mean?

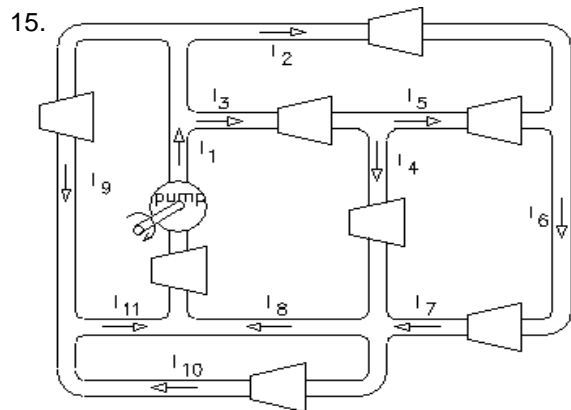

$$I_4 := 0.05 \cdot \frac{\text{m}^3}{\text{s}} \quad I_5 := 0.03 \cdot \frac{\text{m}^3}{\text{s}} \quad I_7 := 0.045 \cdot \frac{\text{m}^3}{\text{s}}$$

$$I_9 := 0.06 \cdot \frac{\text{m}^3}{\text{s}} \quad I_1 = \underline{\hspace{2cm}}$$

$$I_2 = \underline{\hspace{2cm}} \quad I_3 = \underline{\hspace{2cm}}$$

$$I_6 = \underline{\hspace{2cm}} \quad I_8 = \underline{\hspace{2cm}}$$

$$I_{10} = \underline{\hspace{2cm}} \quad I_{11} = \underline{\hspace{2cm}}$$

ECE 2210 / 00 homework # 1, p.4

16.

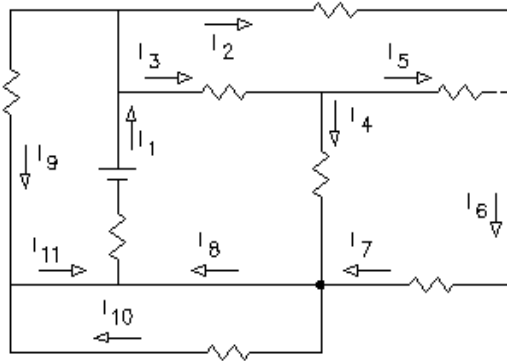

- $I_1 := 100\text{-mA}$ $I_2 := 50\text{-mA}$ $I_3 := 30\text{-mA}$
 $I_6 := 66\text{-mA}$ $I_4 = \underline{\hspace{2cm}}$
 $I_5 = \underline{\hspace{2cm}}$ $I_7 = \underline{\hspace{2cm}}$
 $I_8 = \underline{\hspace{2cm}}$ $I_9 = \underline{\hspace{2cm}}$
 $I_{10} = \underline{\hspace{2cm}}$ $I_{11} = \underline{\hspace{2cm}}$

17. The figure at right shows the pressure differentials across elements in a hydraulic system. The side indicated by the + sign is the higher pressure side. Conversely, - indicates the lower pressure. ΔP_S is the pressure difference supplied by the pump (S for Source). ΔP_2 is the pressure difference driving the left turbine and ΔP_4 is the pressure difference driving the right turbine. Assume no pressure losses or discontinuities in the pipes, joints, or corners; i.e. all connected pipes are at exactly the same pressure. Finally, the fluid has no mass, so gravity and Bernoulli can go take a hike.

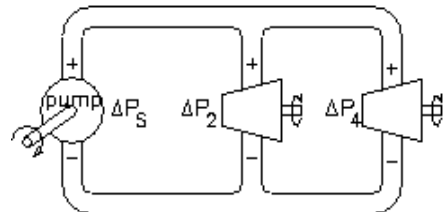

$\Delta P_S := 12 \cdot \frac{\text{N}}{\text{m}^2} = 12 \cdot \text{Pa}$ $\Delta P_2 = \underline{\hspace{2cm}}$ $\Delta P_4 = \underline{\hspace{2cm}}$

Yes, I know that these are ridiculously low pressures for a hydraulic system.

18. The figure at right shows the voltage differentials across elements in an electrical circuit. The side indicated by the + sign is the higher voltage side. Conversely, - indicates the lower voltage. V_S is the voltage supplied by the battery. V_2 is the voltage across the left resistor and V_4 is the voltage across the right resistor. You may assume no voltage drops across any of the wires or connections in practically *all* electrical schematics; i.e. all connected wires are at exactly the same voltage (electrical potential).

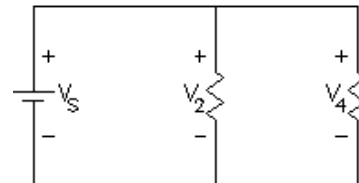

$V_S := 12 \cdot \text{V}$ ($V = \text{volts}$) $V_2 = \underline{\hspace{2cm}}$ $V_4 = \underline{\hspace{2cm}}$

19.

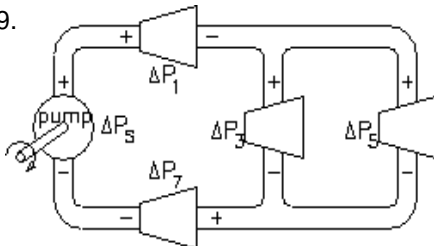

$\Delta P_S := 400 \cdot \text{kPa}$ $\Delta P_1 := 180 \cdot \text{kPa}$ $\Delta P_3 := 100 \cdot \text{kPa}$
 $\Delta P_5 = \underline{\hspace{2cm}}$ $\Delta P_7 = \underline{\hspace{2cm}}$

20.

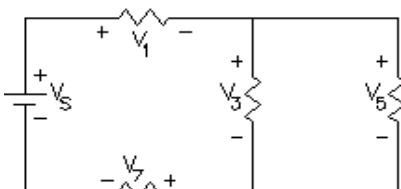

$V_1 := 10 \cdot \text{V}$ $V_5 := 3 \cdot \text{V}$ $V_7 := 2 \cdot \text{V}$
 $V_S = \underline{\hspace{2cm}}$ $V_3 = \underline{\hspace{2cm}}$

ECE 2210 / 00 homework # 1, p.4

ECE 2210 / 00 homework # 1, p.5

21.

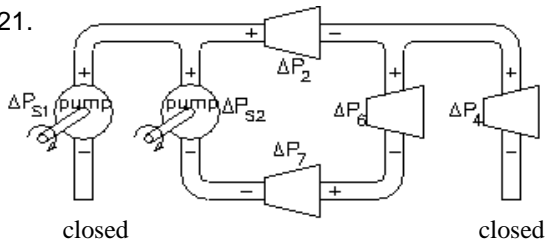

$\Delta P_{S1} := 200 \cdot \text{kPa}$

$\Delta P_{S2} := 150 \cdot \text{kPa}$

$\Delta P_2 := 50 \cdot \text{kPa}$

$\Delta P_6 := 60 \cdot \text{kPa}$

$\Delta P_4 = \underline{\hspace{2cm}}$

$\Delta P_7 = \underline{\hspace{2cm}}$

22.

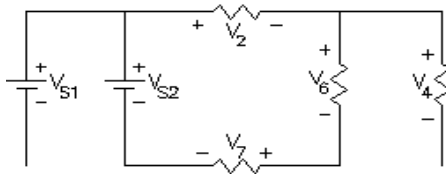

$V_{S1} := 6 \cdot \text{V}$

$V_2 := 2 \cdot \text{V}$

$V_6 := 2.4 \cdot \text{V}$

$V_7 := 3.2 \cdot \text{V}$

$V_{S2} = \underline{\hspace{2cm}}$

$V_4 = \underline{\hspace{2cm}}$

23.

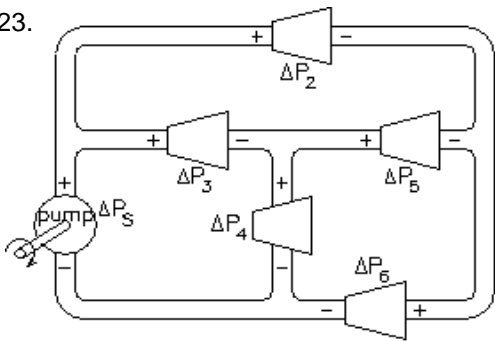

$\Delta P_3 := 120 \cdot \text{kPa}$

$\Delta P_4 := 80 \cdot \text{kPa}$

$\Delta P_6 := 110 \cdot \text{kPa}$

$\Delta P_S = \underline{\hspace{2cm}}$

$\Delta P_2 = \underline{\hspace{2cm}}$

$\Delta P_5 = \underline{\hspace{2cm}}$

24. What does a negative pressure difference physically mean?

25.

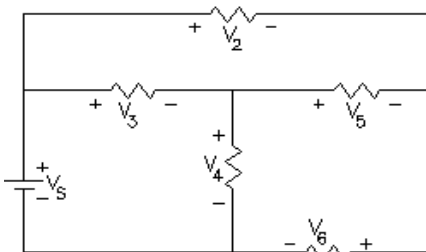

$V_3 := 2.3 \cdot \text{V}$

$V_5 := 0.5 \cdot \text{V}$

$V_6 := 3.2 \cdot \text{V}$

$V_S = \underline{\hspace{2cm}}$

$V_2 = \underline{\hspace{2cm}}$

$V_4 = \underline{\hspace{2cm}}$

26. Watch your + and - signs very carefully now.

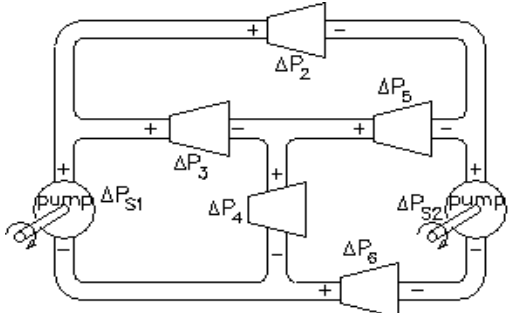

$\Delta P_2 := 140 \cdot \text{kPa}$

$\Delta P_3 := 230 \cdot \text{kPa}$

$\Delta P_4 := 50 \cdot \text{kPa}$

$\Delta P_6 := 210 \cdot \text{kPa}$

$\Delta P_{S1} = \underline{\hspace{2cm}}$

$\Delta P_{S2} = \underline{\hspace{2cm}}$

$\Delta P_5 = \underline{\hspace{2cm}}$

27.

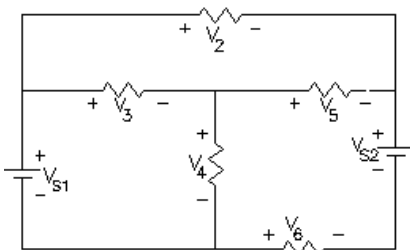

$V_{S1} := 14 \cdot \text{V}$ $V_{S2} := 3 \cdot \text{V}$ $V_2 := 6 \cdot \text{V}$ $V_3 := 4 \cdot \text{V}$

$V_4 = \underline{\hspace{2cm}}$

$V_5 = \underline{\hspace{2cm}}$

$V_6 = \underline{\hspace{2cm}}$

Think about the current through the 2nd battery. What is happening to that battery?

ECE 2210 / 00 homework # 1, p.6

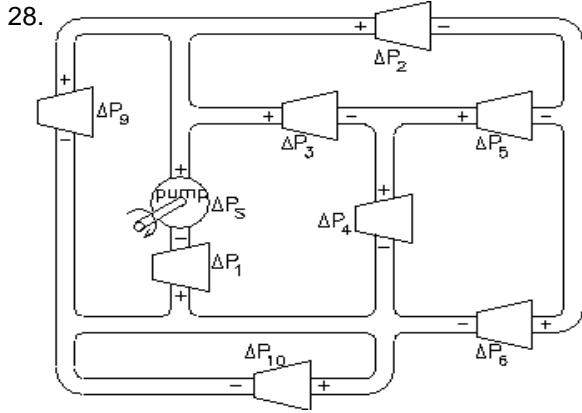

$$\begin{aligned} \Delta P_1 &:= 200 \cdot \text{kPa} & \Delta P_2 &:= 1100 \cdot \text{kPa} \\ \Delta P_3 &:= 600 \cdot \text{kPa} & \Delta P_9 &:= 1800 \cdot \text{kPa} \\ \Delta P_S &= \underline{\hspace{2cm}} & \Delta P_4 &= \underline{\hspace{2cm}} \\ \Delta P_5 &= \underline{\hspace{2cm}} & \Delta P_6 &= \underline{\hspace{2cm}} \\ \Delta P_{10} &= \underline{\hspace{2cm}} \end{aligned}$$

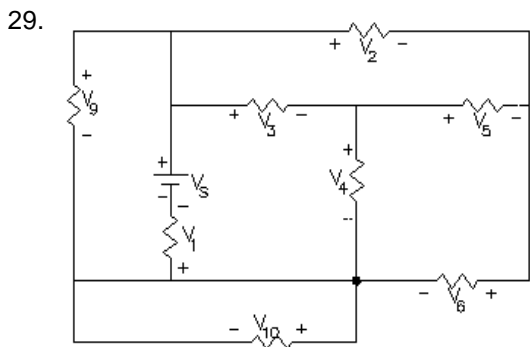

$$\begin{aligned} V_S &:= 18 \cdot \text{V} & V_3 &:= 6 \cdot \text{V} & V_4 &:= 8 \cdot \text{V} & V_5 &:= 2 \cdot \text{V} \\ V_1 &= \underline{\hspace{2cm}} & V_2 &= \underline{\hspace{2cm}} \\ V_6 &= \underline{\hspace{2cm}} & V_9 &= \underline{\hspace{2cm}} \\ V_{10} &= \underline{\hspace{2cm}} \end{aligned}$$

Answers

1. $I_3 = I_4 = I_5 := 0.003 \cdot \frac{\text{m}^3}{\text{s}}$, $I_6 := 0.01 \cdot \frac{\text{m}^3}{\text{s}}$
2. $I_3 = I_4 = I_5 := 0.003 \cdot \text{A}$, $I_6 := 0.01 \cdot \text{A}$
3. $I_6 = I_1 := 34 \cdot \text{mA}$, $I_3 = I_4 := 14 \cdot \text{mA}$
4. $I_4 = I_6 := 0.001 \cdot \frac{\text{m}^3}{\text{s}}$, $I_1 = I_2 = I_7 = I_8 := 0.005 \cdot \frac{\text{m}^3}{\text{s}}$
5. $I_4 = I_6 := 1.2 \cdot \text{mA}$, $I_1 = I_2 = I_7 = I_8 := 5.7 \cdot \text{mA}$
6. $I_1 = I_2 = I_8 := 80 \cdot \text{mA}$, $I_3 := 50 \cdot \text{mA}$, $I_4 = I_5 := 30 \cdot \text{mA}$
7. $I_1 = I_{10} = I_4 = I_5 := 0 \cdot \frac{\text{m}^3}{\text{s}}$, $I_2 = I_3 = I_7 = I_8 := 0.04 \cdot \frac{\text{m}^3}{\text{s}}$
8. $I_1 = I_{10} = I_4 = I_5 := 0 \cdot \text{A}$,
 $I_2 = I_3 = I_7 = I_8 := 0.06 \cdot \text{A}$
9. $I_1 = I_7 := 0.080 \cdot \frac{\text{m}^3}{\text{s}}$, $I_2 := 0.016 \cdot \frac{\text{m}^3}{\text{s}}$, $I_3 := 0.064 \cdot \frac{\text{m}^3}{\text{s}}$
10. $I_1 = I_7 := 42 \cdot \text{mA}$, $I_2 := 12 \cdot \text{mA}$, $I_3 := 30 \cdot \text{mA}$
11. $I_1 := 0.015 \cdot \frac{\text{m}^3}{\text{s}}$, $I_3 := 0.010 \cdot \frac{\text{m}^3}{\text{s}}$, $I_4 := 0.045 \cdot \frac{\text{m}^3}{\text{s}}$, $I_5 := -0.035 \cdot \frac{\text{m}^3}{\text{s}}$
12. Actual flow is in direction opposite to the arrow direction.
13. $I_2 := -15 \cdot \text{mA}$, $I_3 := 25 \cdot \text{mA}$, $I_4 := 45 \cdot \text{mA}$, $I_7 := 10 \cdot \text{mA}$
14. "
15. $I_1 := 0.155 \cdot \frac{\text{m}^3}{\text{s}}$, $I_2 := 0.015 \cdot \frac{\text{m}^3}{\text{s}}$, $I_3 := 0.080 \cdot \frac{\text{m}^3}{\text{s}}$, $I_6 := 0.045 \cdot \frac{\text{m}^3}{\text{s}}$, $I_8 := 0.095 \cdot \frac{\text{m}^3}{\text{s}}$, $I_{10} := 0 \cdot \frac{\text{m}^3}{\text{s}}$, $I_{11} := 0.060 \cdot \frac{\text{m}^3}{\text{s}}$
16. $I_4 := 14 \cdot \text{mA}$, $I_5 := 16 \cdot \text{mA}$, $I_7 := 66 \cdot \text{mA}$, $I_8 := 80 \cdot \text{mA}$, $I_9 := 20 \cdot \text{mA}$, $I_{10} := 0 \cdot \text{mA}$, $I_{11} := 20 \cdot \text{mA}$
17. $\Delta P_2 = \Delta P_4 := 12 \cdot \text{Pa}$
18. $V_2 = V_4 := 12 \cdot \text{V}$
19. $\Delta P_5 := 100 \cdot \text{kPa}$, $\Delta P_7 := 120 \cdot \text{kPa}$
20. $V_S := 15 \cdot \text{V}$, $V_3 := 3 \cdot \text{V}$
21. $\Delta P_4 := 0 \cdot \text{kPa}$, $\Delta P_7 := 40 \cdot \text{kPa}$
22. $V_{S2} := 7.6 \cdot \text{V}$, $V_4 := 0 \cdot \text{V}$
23. $\Delta P_S := 200 \cdot \text{kPa}$, $\Delta P_2 := 90 \cdot \text{kPa}$, $\Delta P_5 := -30 \cdot \text{kPa}$
24. The actual + & - should be reversed from those on drawing
25. $V_S := 6 \cdot \text{V}$, $V_2 := 2.8 \cdot \text{V}$, $V_4 := 3.7 \cdot \text{V}$
26. $\Delta P_{S1} := 280 \cdot \text{kPa}$, $\Delta P_{S2} := 350 \cdot \text{kPa}$, $\Delta P_5 := -90 \cdot \text{kPa}$
27. $V_4 := 10 \cdot \text{V}$, $V_5 := 2 \cdot \text{V}$, $V_6 := -5 \cdot \text{V}$ battery is charging
28. $\Delta P_S := 2000 \cdot \text{kPa}$, $\Delta P_4 := 1200 \cdot \text{kPa}$, $\Delta P_5 := 500 \cdot \text{kPa}$,
 $\Delta P_6 := 700 \cdot \text{kPa}$, $\Delta P_{10} := 0 \cdot \text{kPa}$
29. $V_1 := 4 \cdot \text{V}$, $V_2 := 8 \cdot \text{V}$, $V_6 := 6 \cdot \text{V}$, $V_9 := 14 \cdot \text{V}$, $V_{10} := 0 \cdot \text{V}$

ECE 2210 / 00 homework # 2

Due: Mon, 1/25/21

You may do the following problems here or on your own paper. But, since you have the answers, **you MUST show your work to get credit.**

1. Ohm's law

Consider the figure at right
For each of the cases below,
find the missing value.

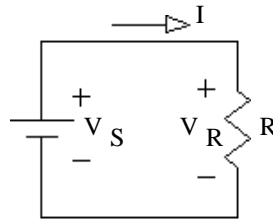

a) $I := 0.01 \cdot A$ $V_R := 4 \cdot V$ $R = ?$

b) $I := 50 \cdot mA$ $R := 560 \cdot \Omega$ $V_R = ?$

c) $V_R := 12 \cdot V$ $R := 1.5 \cdot k\Omega$ $I = ?$

2. Power and Ohm's law. Same circuit as above. For each of the cases below, find the missing values.

a) $I := 5 \cdot mA$ $R := 2 \cdot k\Omega$ $V_R =$ $P_R =$

b) $V_R := 25 \cdot V$ $R := 100 \cdot \Omega$ $I =$ $P_R =$

c) $V_R := 20 \cdot V$ $I := 0.01 \cdot A$ $R =$ $P_R =$

Ignore the fact that the following items run on AC

d) $P_R := 900 \cdot W$ $V_R := 120 \cdot V$ $I =$ $R =$
Toaster

e) $P_R := 1500 \cdot W$ $R := 9.6 \cdot \Omega$ $I =$ $V_S =$
Hair drier

f) $P_R := 2500 \cdot W$ $I := 10.5 \cdot A$ $R =$ $V_S =$
Electric oven

3. Find the equivalent resistance a) of each of these networks, i.e. what would an ohmmeter read if hooked to the terminals.

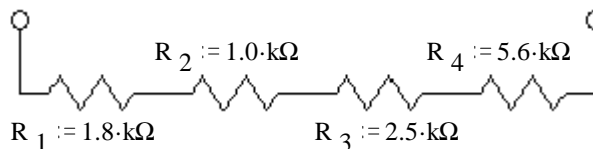

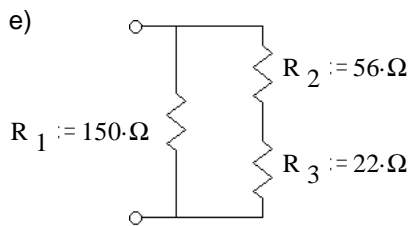
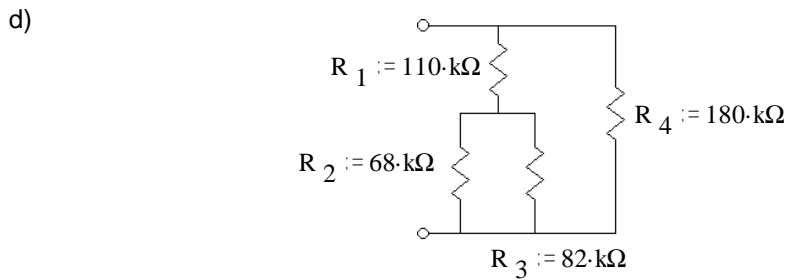
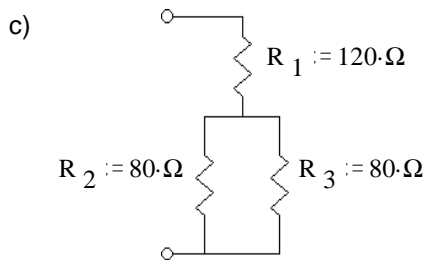
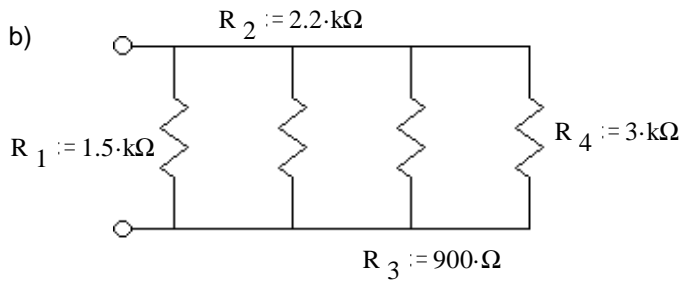

Answers

1. a) $R := 400 \cdot \Omega$

b) $V_R := 28 \cdot \text{V}$

c) $I := 8 \cdot \text{mA}$

2. a) $V_R := 10 \cdot \text{V}$ $P_R := 50 \cdot \text{mW}$

b) $I := 0.25 \cdot \text{A}$ $P_R := 6.25 \cdot \text{W}$

c) $R := 2.0 \cdot \text{k}\Omega$ $P_R := 200 \cdot \text{mW}$

d) $I := 7.5 \cdot \text{A}$ $R := 16 \cdot \Omega$

e) $I := 12.5 \cdot \text{A}$ $V_S := 120 \cdot \text{V}$

f) $R := 22.7 \cdot \Omega$ $V_S := 238 \cdot \text{V}$

3. a) $R_{eq} := 10.9 \cdot \text{k}\Omega$

b) $R_{eq} := 390 \cdot \Omega$

c) $R_{eq} := 160 \cdot \Omega$

d) $R_{eq} := 81 \cdot \text{k}\Omega$

e) $R_{eq} := 51.3 \cdot \Omega$