

# Lab Notebook

A. Stolp, 1/8/00, rev 1/7/14

This is what I expect in your notebook, and some suggestions of how to organize it.

## General:

- Title.
- Date. Get into the habit of dating every piece of paper you write on. It will save you trouble someday.
- Objective(s) and/or introduction. Read the entire lab before lab time and write your own objective(s) and/or introduction to the lab. If you copy my objectives verbatim, you may not get full credit.

## Procedures:

- Describe what you do in lab in such a way that you could repeat the lab again later without referring to a handout. Do not cut-and-paste from the lab handout. You are supposed to be learning how to keep a notebook of your own
- Draw circuit diagrams of everything that you build. A diagram is the fastest and easiest way to describe a circuit. Include parts values. Include equipment and instrument information in at least the first diagram where each instrument is used. (Example: write "Agilent E3631A" next to the voltage supply in your diagram.)
- Describe how you use the lab equipment, especially any new procedures as you learn them. A major objective of your work in the lab is that you learn how to use this equipment.
- Describe the problems that you encounter and how you solve those problems.
- Answer the lab handout questions. You will find many questions sprinkled throughout the lab handouts. Answer in the form of a complete sentence. Same when you are asked to "comment" on something— comment in a complete sentence.

## Data:

- Take all your raw data and measurements directly into your notebook. If you process the data, include your calculations.
- List data in tables and plot graphs whenever possible. Tables are especially good when comparing data, such as calculated values v.s. measured values, or measured values obtained from two or three different methods. Sometimes you can compare data as separate graph curves on the same set of axes. When tables and graphs are not appropriate, insure that data elements (measurements) stand out clearly. No one should have to hunt through your write-up for data.
- Draw graphs to scale, using a ruler. Make the horizontal axis the independent variable (the one you change or control) and the vertical axis the dependent variable (the result which you measure). Plot each data point as a dot, an X or a cross. Draw a smooth, averaged line through the points. Generally, the line will not connect all the points, and may touch very few of them. Title each graph and label the axes. You may make graphs on a computer and tape them in your notebook.

## Conclusion:

The conclusion is an important part of the lab write-up, because it tells what you've learned from the experiment. Say what you got out of the experiment. Specifically, look back at your objectives, and tell how you met them.

Discuss your results/measurements/data relative to their quality, i.e., how close were they to expected results or to calculated values? How close were measurements obtained by different methods to each other? How accurate were your results? Try to account for differences. How well did circuits work?

A lab notebook may be any notebook that you cannot insert pages into, IE spiral or bound.

## Lab Notebook handout

# Standard 5% resistor values

Color Bands		3	3	3	3	3	3	3	3	4
1	2	gold	blk	brn	red	org	yel	grn	blu	
brn	blk		10	100	1.0	10	100	1.0	10	gold
brn	brn		11	110	1.1	11	110	1.1	11	gold
brn	red		12	120	1.2	12	120	1.2	12	gold
brn	org		13	130	1.3	13	130	1.3	13	gold
brn	grn		15	150	1.5	15	150	1.5	15	gold
brn	blu		16	160	1.6	16	160	1.6	16	gold
brn	gry		18	180	1.8	18	180	1.8	18	gold
red	blk		20	200	2.0	20	200	2.0	20	gold
red	red		22	220	2.2	22	220	2.2	22	gold
red	yel		24	240	2.4	24	240	2.4	24	gold
red	vio	2.7	27	270	2.7	27	270	2.7	27	gold
org	blk	3.0	30	300	3.0	30	300	3.0	30	gold
org	org	3.3	33	330	3.3	33	330	3.3	33	gold
org	blu	3.6	36	360	3.6	36	360	3.6	36	gold
org	wht	3.9	39	390	3.9	39	390	3.9	39	gold
yel	org	4.3	43	430	4.3	43	430	4.3	43	gold
yel	vio	4.7	47	470	4.7	47	470	4.7	47	gold
grn	brn	5.1	51	510	5.1	51	510	5.1	51	gold
grn	blu	5.6	56	560	5.6	56	560	5.6	56	gold
blu	red	6.2	62	620	6.2	62	620	6.2	62	gold
blu	gry	6.8	68	680	6.8	68	680	6.8	68	gold
vio	grn	7.5	75	750	7.5	75	750	7.5	75	gold
gry	red	8.2	82	820	8.2	82	820	8.2	82	gold
wht	brn	9.1	91	910	9.1	91	910	9.1	91	gold

**Ω**
**k Ω**
**M Ω**
5%

**University of Utah**  
**Electrical & Computer Engineering Department**  
 ECE 2210/2200 Lab 1  
**Introduction**

A. Stolp, 1/8/00  
 Rev. A.S., 1/7/14, 1/6/20

**Objectives**

- 1 Teach the student to keep an engineering notebook.
- 2 Talk about lab practices, check-off, and grading.
- 3 Introduce the lab bench equipment.
- 4 Teach wiring techniques.
- 5 Show how voltmeters, ammeters, and ohmmeters are used.
- 6 Teach good data reporting and graphing.

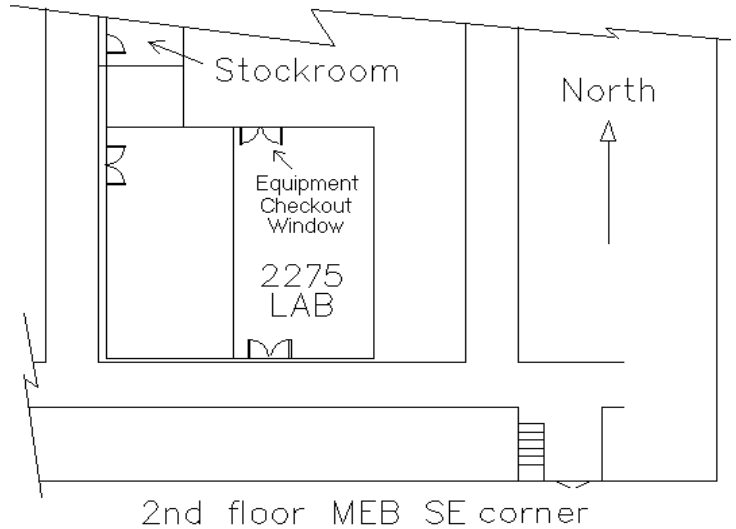

**Parts to be supplied by the student:**

- Lab notebook for all ECE labs
- ECE 2210 parts kit, OR individual parts below
- 100 Ω, 270 Ω, 560 Ω, two 1 kΩ, two 2.0 kΩ, and 2.2 kΩ resistors (see table on p.5 for band colors)
- Breadboard and wires

The electrical parts may be bought from stockroom. Buy parts using your “U-Card”. They can’t accept cash.

**Check out from stockroom:**

- Servo
- DMM (Digital Multi-meter)

**General**

Choose a workbench space with an Agilent or HP 34401A multimeter and an Agilent or HP E3631A DC power supply, perhaps grouped in a cluster like the one shown at right. (You may use different equipment but then you’ll have to modify the specific instructions found in this lab. You may also need another multi-meter and additional help from your lab TA.)

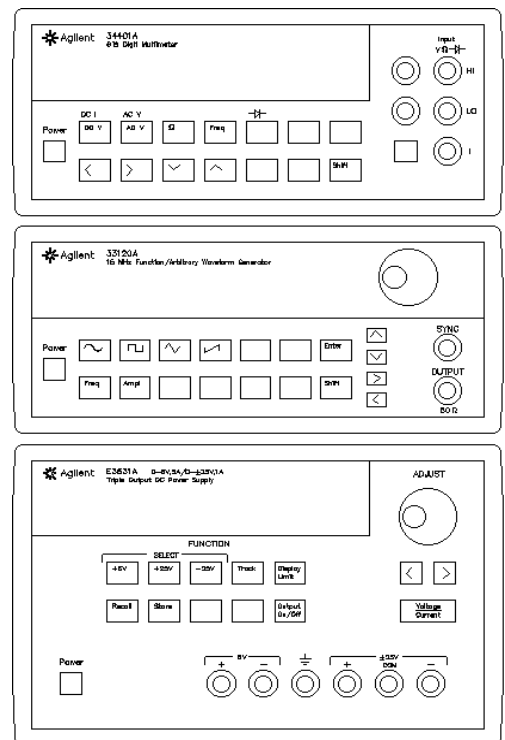

**Lab Notebook**

As engineers many of you will be paid to do research, development, and invention. The companies that employ you may be interested in obtaining patents on these developments. In patents, timing is important—you’ve got to be first, and you’ve got to be able to prove it. A well-kept engineering notebook can be used in court as part of your proof. The number-one purpose of a true engineering notebook is to keep an accurate, chronological record

of your work, and **you** may need to keep one someday for your high-paying job. Many non-R&D jobs also require a similar notebook for record keeping or billing purposes. In this class you'll need to keep one to get a grade. We're going to pretend that it's job training. If your future boss asks you to keep an engineering notebook and all you can do is ask, "huh, what's that?" Both you and the "U" will look bad.

Keeping a true engineering lab notebook, acceptable in court, is fairly involved. You need to write everything in ink, all pages must be numbered, dated, and signed by others, etc. etc.. By these standards we'll be quite lax in this class. But we will pay particular attention to the following things:

- Work in your lab notebook at lab time—no scribble sheets for data so that you can “write it down neatly later.” Before you leave the lab you will need to get your instructor to (check-off) initial your book. Some or all of your notebook may be graded at this time.
- Write clearly and make sure your work stands on its own, without reference to the handout.
- Follow the guidelines on the “Lab Notebook” handout for procedures, data, and conclusions.
- Use lots of drawings, tables, and graphs, and label them well. Often these are both easier to create and better than written text.

My main objectives are that you to work in your notebook, and that you make that work useful for later reference.

**Check-off:**

When you are finished with your lab, you should call your lab TA over to check you off. At this time, you should be able to demonstrate a working circuit, answer questions about what you did, and show your finished notebook. You'll get part or all of your lab grade right on the spot. Check-off becomes a problem if you ever miss your normal lab time, so try not to. If you have to miss a lab, make arrangements with your TA to make it up. Most TAs will accept the check-off from another TA or from me.

**Experiment**

**TA Demonstration** (If your TA doesn't give you a lecture or not do this part of the lab for you (takes about an hour), please report to Arn)

Your lab instructor will do this part of today's lab as demonstration and write example notebook entries on the whiteboard. If you follow along with your TA and write the same things in your notebook that your TA writes on the board, you won't have to re-do this part later. The following paragraphs are written as though they are instructions to you, but your TA will show you how to do them.

Construct the circuit shown at right. For  $V_s$ , use the +25V and COM outputs of an Agilent or HP E3631A DC power supply. Turn it on, wait for it to show “OUTPUT OFF”, hit the “Output On/Off” button and the “+25V” button. Use the knob to turn up the voltage to a few volts. The voltmeter in the power

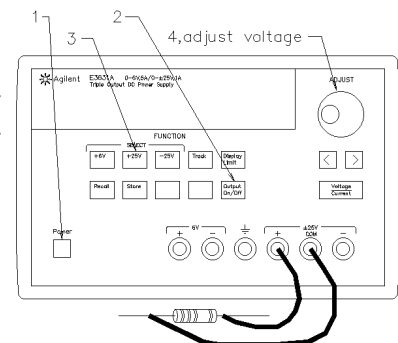
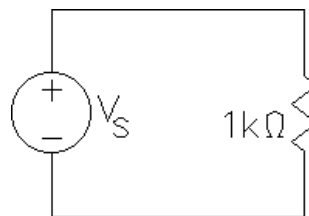

supply will show the output voltage but the notice that the ammeter isn't sensitive enough to accurately show the current. Comment in your lab notebook.

First, let's check Kirchoff's voltage law. We'll add a voltmeter to the circuit (shown as a circle with a V) and see if the voltage across the resistor is the same as the voltage at the power supply. Hook up a voltmeter and turn it on. Adjust the power supply to several different voltages. Is the voltage across the resistor the same as the power supply voltage? From now on you may rely on the internal voltmeter within the power supply.

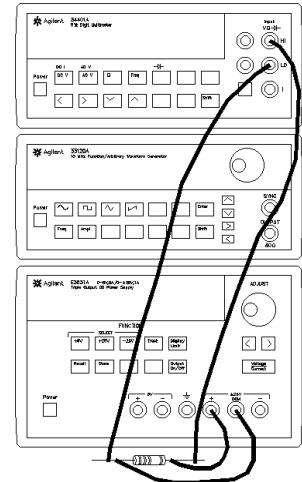
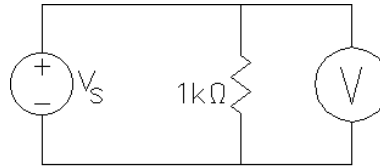

Next, let's use the multimeter as an ammeter and make a new circuit. The ammeter is shown as a circle with an A. Notice that it is wired in the circuit so that the current must flow *through* it. Before rewiring your circuit, turn off the output of the power supply (hit the "Output On/Off" button). An ideal ammeter is a very low resistance and it is very easy to "short" the power supply while rewiring. Once you have the new circuit, hit "Shift" and "DC I" on the multimeter and turn the power supply output back on. Can you now read the voltage on the power supply and the current on the multimeter?

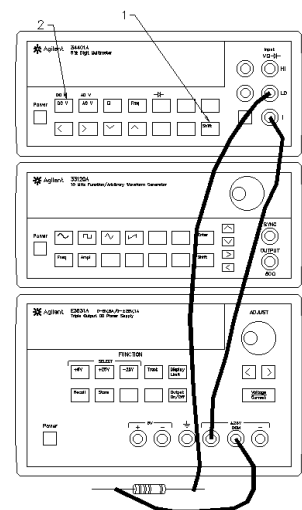
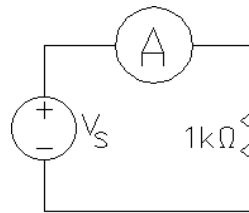

Whenever you make a circuit, make a drawing of your circuit in your lab notebook and indicate that you built it. On the first such drawing indicate what instruments you used by brand name and model.

Take a set of current and voltage measurements as you vary the power supply output between 0 V and 10 V. Make a table for your data and include space for several more columns of data that you'll take later. Make a current (I, mA) v.s. voltage (V, volts) graph for this 1 kΩ resistor. Be sure to label everything well and draw your graph accurately and to scale. Make it clear what circuit these measurements refer to. Comment on the shape of your graph and what that implies about the linearity of resistors.

Replace the 1 kΩ resistor with two 1 kΩ resistors in series. Use the breadboard (see figure on next page) to make this wiring job easier. Take another set of measurements and make another line on your graph. Comment in your lab notebook about and about effects of adding two in series. Find the slopes of all the lines on the graph and relate the slopes to the resistance values.

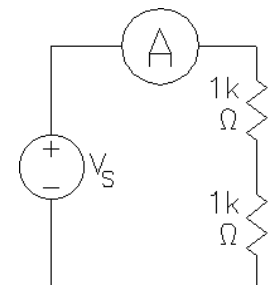

This ends the demonstration part of this lab. You should now have some idea how to use the lab equipment, how to wire circuits, and how to keep a lab notebook. For the remainder of this lab, you may work with ONE partner or on your own. No groups of more than two people.

## Student Lab

If you haven't already done so, begin your lab notebook entries with the title, date, and objective(s).

### Experiment 1, Basic wiring and measurements

Construct the same circuit that your TA made with the single  $1\text{k}\Omega$  resistor. Use a multimeter as an ammeter. You may use the breadboard if you like, the breadboard wiring is shown at right. A  $1\text{k}\Omega$  resistor has the following color band pattern: brn, blk, red, gold, blank (the bands should be scrunched towards the left, if not, turn the resistor over).

Turn on the power supply and turn up the voltage. If you watched the TA demonstration and recorded the data

taken then, you may simply check that your circuit is doing about the same thing and go on to the next paragraph. If you didn't watch the TA or record his/her data, go back to that section, make the circuit drawing, answer the questions, take the data, make the graph, and comment as described there for both the single and the series pair of resistors.

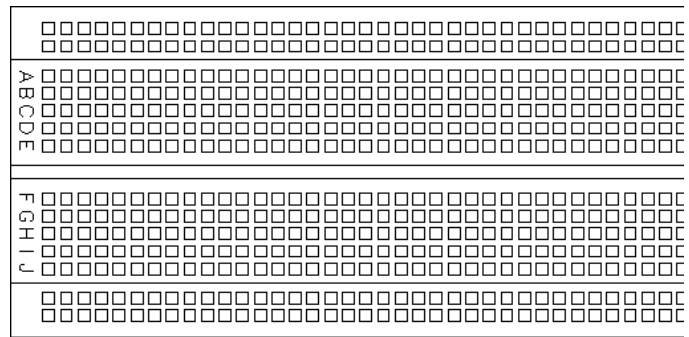

Breadboard

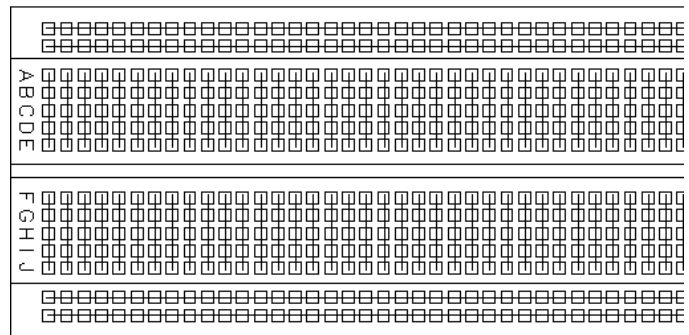

Breadboard with internal connections shown

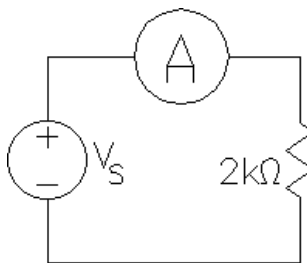

Replace the  $1\text{k}\Omega$  resistor (R) with a  $2\text{k}\Omega$  resistor. Take another column of data in your table and add another line on your graph.

Repeat for the circuit at right, the parallel combination of two  $2\text{k}\Omega$  resistors.

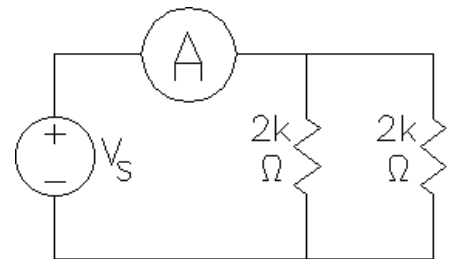

Comment on the shape of your graph lines. What does this imply about resistors? For each of your straight lines, calculate the ratio of voltage over current ( $V/I$ ). This would be the inverse of the slope ( $1/\text{slope} = \text{run}/\text{rise}$ ). Comment on the numbers that you get. How do they compare to the resistor values or equivalent resistor values of series and parallel combinations of resistors?

### Experiment 2, Voltage v.s. resistance at a constant current

Make a table in your notebook like the one shown on the next page.

Find the six resistors shown in the table in the parts you bought. Switch the multi-meter to the " $\Omega$ " range and use it to measure the value of each resistor (simple touch the meter leads to the resistor leads). Preferably, don't touch the leads yourself while measuring or your body resistance will effect the reading (not really an issue at these resistor values).

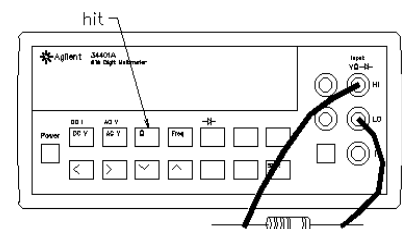

Select one of the resistors from the table and make a circuit like the ones you've been making. Using both the knob and the arrow keys, adjust the power supply output until the ammeter reads 4 mA. Enter the measured voltage in your table. Repeat for all six resistors. (**Hint:** It's much easier to hook all the resistors in series, adjust the current to 4 mA only one time, and then measure the voltage across each resistor with the second DMM.)

Color code	Nominal Value ( $\Omega$ )	Measured Value ( $\Omega$ )	Volts needed to make 4 mA flow
brn, blk, brn, gold	100		
red, vio, brn, gold	270		
grn, blu, brn, gold	560		
brn, blk, red, gold	1000 (1k)		
red, blk, red, gold	2000 (2k)		
red, red, red, gold	2200 (2.2k)		

Graph your results, resistance on the x-axis and “volts to get 4 mA” on the y-axis. Comment on the shape of your graph and on what that implies about the relationship between voltage and resistance at a given current.

### Experiment 3, Simple Servo Device

The servo is the device that you checked out which is built on a little plastic board. Examine it now and find the power connections (Red (+), Green or Black (com), & Blue(-) banana jacks). Turn off the power switch on the servo and connect the power as shown. Watch out, the HP/Agilent's + connection and it's - connection are *both* red. Furthermore, - is on the right side of Common (ground for our servo) and + is on the left. BAD design!

### Power supply setup

Turn on the Agilent power supply and activate the output by hitting the **Output On/Off** Button. Push the “+25V” button and then push and hold the **Track** button for a few seconds so that the - output will automatically “track” (be the same voltage value as) the + output. Adjust the + output to 6 V. Now the power supply will output  $\pm 6$  V. If you hit the **Store** button twice, you can store this setup as configuration #1. Next time you use this bench you can recall the  $\pm 6$  V configuration by simply hitting the **Recall** button twice (if no one else changed it in the meantime). Turn on the outputs of the power supply and turn on the servo.

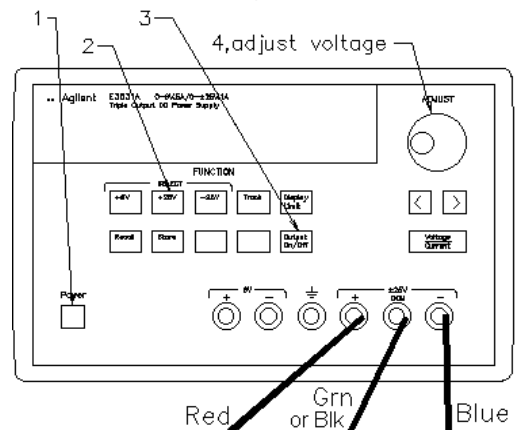

Try to remember how to adjust power supply to  $\pm 6$  V and how to hook up the servo. You will do this again and again in the labs to come. If you don't think that you will remember, keep a copy of this lab handout for the detailed instructions presented here. You may even want to tape these instructions into your lab notebook.

Play around with the input position shaft and watch the motor turn the output shaft to follow. (If the servo oscillates, turn down the gain.) In your lab notebook, write a short description of what the servo does. This is a very crude, slow, and weak servo, but it does illustrate how they work. Imagine what this, or a more powerful, servo could do if the output shaft was hooked to other mechanical devices, maybe a cutting device, or digging tool, or steering device, or... Write down at least 3 uses for servos. Do you think that you might work with servos in subsequent classes and later as an engineer? Mechanical engineering students should definitely answer “yes” here. Chemical Engineers, Material Scientists, and Environmental Engineers (a branch of Civil) are more likely to see process and temperature control systems, but they turn out to be quite similar. The servo is just a control system that controls a mechanical motion. For you Mining and Civil Engineers (Other than Environmental) that don't plan to go to grad school are less likely to deal directly with control systems. Although, I might point out that the Citicorp building has a large servo controlled mass at the top of the building that reduces its sway on windy days.

In the first two experiments of this lab you learned a little about resistors. At first thought a resistor may seem like a pretty worthless part, but resistors are used a lot in electronic circuits. About how many resistors are used in the servo circuit? Determine the value of at least one of the resistors from it's color code (try the most common value).

You will see this servo again many times in the lab. I will try use it to show you how the things you learn in class and in lab relate to something mechanical—something useful.

### Conclude

Call your lab instructor over to check you off. Usually you do this before you tear down your final circuit. Be prepared to discuss your measurements, calculations, and conclusions and to show off your notebook.

Write a conclusion in your notebook. Make sure that you touch on each of the subjects in your objectives. Mention any problems that you encountered in this lab and how you overcame them.

This sort of check-off and conclusion will be required at the end of each lab, even if it's not specifically asked for in the lab handout. Before leaving, make sure everything is turned off and return everything that you checked out.

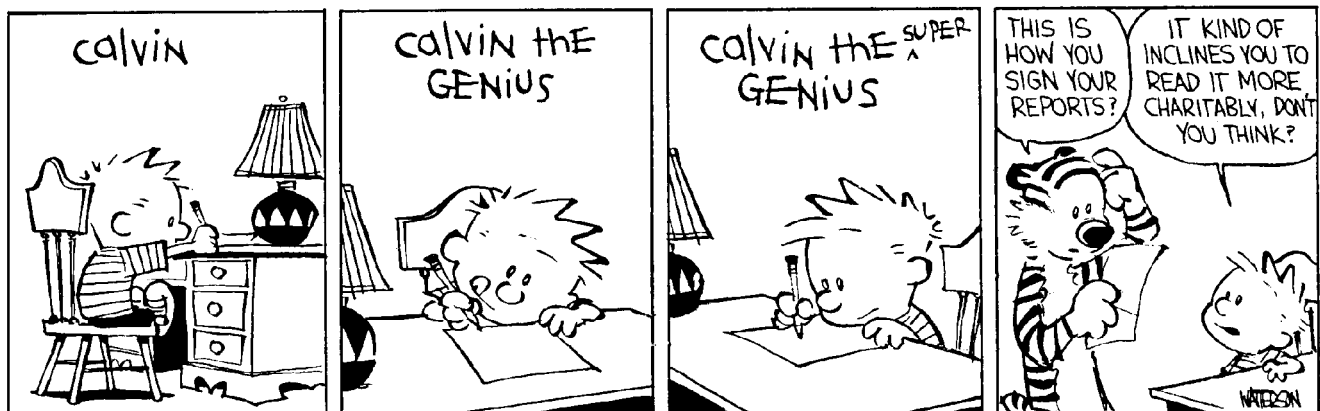



**University of Utah**  
**Electrical & Computer Engineering Department**  
 ECE 2210/2200  
 Experiment No. 2  
**DC Circuits**

A. Stolp, 9/27/99  
 rev, A.S, 1/6/13, 9/6/18(wire colors)

**Objectives**

- 1.) Verify Ohm's and Kirchoff's laws.
- 2.) Verify series and parallel equivalence, and the divider rules.
- 3.) Feel the power dissipation of a resistor as heat.
- 4.) See that the position sensors in the servo are simply voltage dividers.

**Parts to be supplied by the student:** (Parts in **bold** are new to this lab)

- **Two 390  $\Omega$** , 560  $\Omega$ , and 1 k $\Omega$  resistors, (The little resistors you buy are rated for  $\frac{1}{4}$  watt power dissipation) (390 is orange-white-brown-gold)
- Breadboard and wires

**Check out from stockroom:**

- Portable digital multimeter
- Servo

**Experiment**

**Resistor measurements**

Use the Agilent digital multimeter as an ohmmeter to measure the resistance of each of the four resistors listed above. Record these values for use in later calculations.

**Basic Laws**

Build the circuit shown at right. For  $V_s$ , use the +25V and COM outputs of an Agilent or HP E3631A DC power supply. Notice that the ammeter is in the bottom wire (negative return wire). Set the power supply output to about 10 volts (10 V). You may rely on the voltmeter built into the power supply. Record the actual voltage in your notebook.

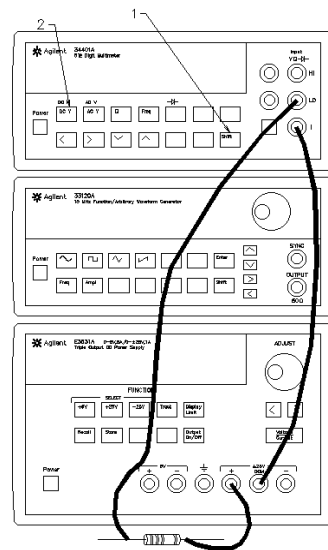
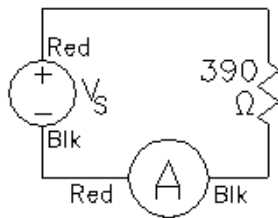

Record the current measured by the ammeter. Why does it show a negative current? Swap the leads to the ammeter, what changes and why?

Move the ammeter to the top wire of the circuit, as shown in the schematic at right. Is the current the same in the top wire? Comment on Kirchoff's current law (KCL).

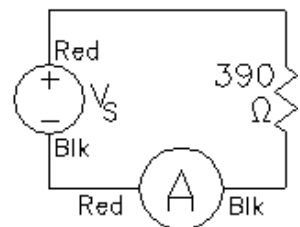

Use Ohm's law to calculate the resistance of your resistor. (Voltage shown on the power supply divided by the current shown on the ammeter.) How does this calculated value compare to what you measured earlier with the ohmmeter?

Calculate the power dissipated by the resistor. Is it within the resistor's rating ( $\leq 1/4$  watt)? Energy is power times time ( $E = Pt$ ). If the resistor is dissipating power, what is happening to the energy? Carefully feel the resistor. Is it warm? If you can't feel the heat, turn up the voltage to 15 or 20 V and try again. Now be careful, the resistor can get hot.

### Series circuit

Wire any three of your resistors in series with your ammeter and connect them to the power supply (set at about 10 V). As you should whenever you make a new circuit, sketch the circuit in your notebook, showing all the pertinent values. Also

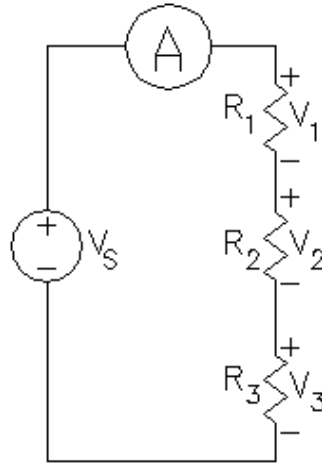

label your resistors as  $R_1$ ,  $R_2$  and  $R_3$ . Use the portable digital voltmeter to measure (and of course record) the voltage across each element of your circuit, including your ammeter. Measure the voltage across  $R_1$  and  $R_2$  together (measure from the bottom of  $R_2$  to the top of  $R_1$  and call this voltage  $V_{12}$ ). Measure the voltage across  $R_2$  and  $R_3$  together ( $V_{23}$ ), and finally measure the voltage across all three resistors together ( $V_{123}$ ). Use the concepts of Kirchoff's voltage law (KVL), series equivalence, and the voltage divider rule to calculate several of the voltages that you've just measured. Comment on the agreement between theory and measurement.

Use Ohm's law and your measurements to calculate the resistance of  $R_1$  and  $R_2$  together ( $V_{12} / I$ ), and all three resistors together ( $V_{123} / I$ ). Comment on the agreement between these values and those you get from series equivalence calculations ( $R_1+R_2$ , and  $R_1+R_2+R_3$ ).

Use Ohm's law to calculate the resistance of the ammeter. An ideal ammeter would have zero resistance, but our ammeter is not ideal. Keep this in mind as you do the following sections of this lab.

### Meters

A voltmeter measures the voltage difference

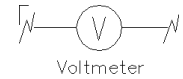

**ACROSS** it. An ideal voltmeter acts like an open circuit (no connection) and can be connected between any two points in the circuit to show the voltage (potential) difference between those two points.

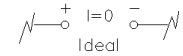

They are fairly hard to misuse unless you're dealing with high voltages—and we'll try to avoid that in here. The registrar doesn't like it when we kill tuition sources.



An ammeter, however, is very easy to misuse. An ammeter measures the current that passes **THROUGH** it. An ideal ammeter acts like wire. A wire in the wrong place is known as a short circuit (a direct, low resistance connection, usually unwanted). An ammeter makes a connection, and if you're not careful, you'll make a connection that you don't want. To use an ammeter; make your complete circuit first, then open part of the circuit and replace a wire or connection with the ammeter. The key phrase here is *open up*. If you aren't breaking open some connection in order to insert the ammeter, then you're doing something wrong.

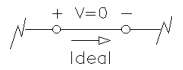

## Parallel circuit

Build the circuit shown, using any two of your resistors in parallel. Ignore the “dotted” ammeters for now. Label your resistors as  $R_1$  and  $R_2$ . Record the voltage across the parallel resistors (shown on the power supply).

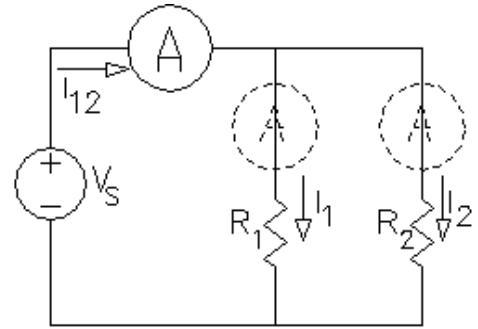

Record the ammeter reading ( $I_{12}$ ). Move the ammeter into the two other positions shown by the dotted outlines in the drawing above and record all the currents  $I_1$  and  $I_2$ .

Since current must flow through the ammeter for it to work, you will need to do some rewiring each time you move the ammeter (See box on previous page). Admittedly, this is a pain in the neck but it is good practice. Be very careful with your wiring.

Now calculate  $I_1$  and  $I_2$  from the power supply voltage and the resistance values. Add these to calculate the current  $I_{12}$ . Comment on the agreement between these calculations and your ammeter measurements.

What is the equivalent resistance of  $R_1$  and  $R_2$  together calculated from the formula for parallel resistors? Now use Ohm's law and your measurements to calculate the equivalent resistance ( $V / I_{12}$ ). Comment on the agreement between these values.

## Series-parallel circuit

The resistors in the circuits you have made so far have been either all in series or all in parallel. In a series-parallel circuit some resistors are in series and some are in parallel at the same time. Design a series-parallel circuit using all four of your resistors. Make your circuit and connect it to the power supply through the ammeter. Record the power supply voltage (which is the voltage across the entire resistor network) and the ammeter reading (which should be the total current through the entire network). Use Ohm's law and measurements to calculate the resistance of all the resistor network. Use series and parallel formulas to calculate the resistance of the network from the individual resistor values. Comment on the agreement between these values.

Make at least one more voltage measurement across and one more current measurement elsewhere in the circuit. Assume that the power supply voltage is correct and use theory to find the same voltage and current you just measured. Comment on the agreement between theory and measurement.

## Voltage Dividers in the Simple Servo

Turn off the power switch on the servo and hook it up to the power supply. Adjust the power supply to provide  $\pm 6$  V as you did in the first lab. If you've forgotten how to do this, refer back to the lab handout for lab 1.

Remember that you may be able to recall the  $\pm 6$  V configuration by simply hitting the **Recall** button twice (If no one else changed it in the meantime). Turn on the power switch on the servo and make sure that it is functioning properly.

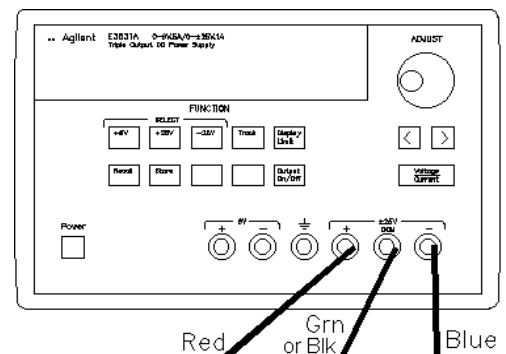

## Potentiometers used as position sensors

If you look at the servo, you'll see three potentiometers (pots). One is used to adjust the gain of the circuit, you will learn about that near the end of the semester. The other two are used as position sensors. They translate shaft position into voltage. When the shaft is turned, the voltage on the center lead changes.

One of the pots is labeled "Input Position" and is the one you turn by hand. Another is coupled to the output shaft of the motor and geartrain and is turned by the servo. The circuit compares the positions of these two pots and amplifies the difference to run the motor in the correct direction to eliminate that difference. Each of these pots is simply a voltage divider.

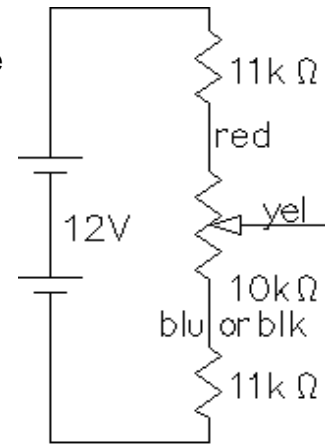

Measure the voltage between the two outside leads of the "Input Position" pot. Turn the pot through its range. Does this voltage change significantly? Now measure from the blue (or black) to the yellow lead and try it again. What range of voltages do you measure?

Look at the schematic that shows how this part of the servo circuit is wired. Calculate the voltage that you expect to see across the 10 kΩ pot. Compare to the measured voltage. Explain why blue-to-yellow lead measurements make sense.

Measure the voltage from the black to the brown leads of the other position sensor as you make the motor turn through its range of motion. Compare to the similar measurement at the first pot.

## Conclude

Before you put everything away, call your lab instructor over to check you off. Write a conclusion in your notebook. Discuss the agreement of measurements and calculations. If you are concerned about disagreements, make some % error calculations. Usually your errors are smaller than they at first appear. Also remember that no measuring instrument is perfect and neither are parts. Mention any problems that you encountered in this lab and how you overcame them.

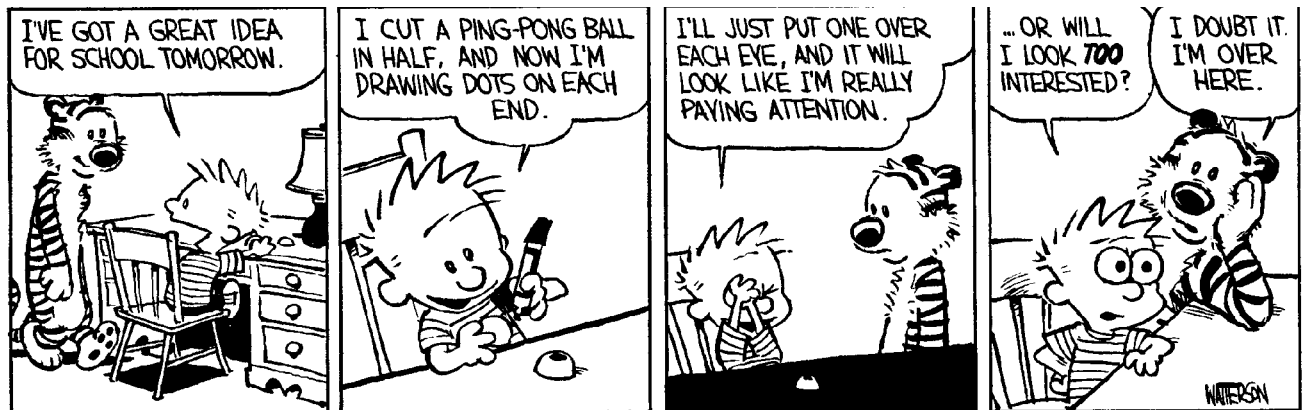

**University of Utah**  
**Electrical & Computer Engineering Department**  
 ECE 2210/2200  
 Experiment No. 3  
**Thévenin & Superposition**

A. Stolp, 1/26/00  
 rev,12/16/14

**Objectives**

- 1.) Learn about Thévenin equivalent circuits.
- 2.) Find the Thévenin equivalent of the servo's "Input Position" potentiometer.
- 3.) Learn about Superposition

**Parts to be supplied by the student:** (Parts in **bold** are new to this lab)

- 100  $\Omega$ , **220  $\Omega$** , 270  $\Omega$ , Two 390  $\Omega$ , 560  $\Omega$ , and 1 k $\Omega$  resistors
- Breadboard and wires
- **500  $\Omega$  trim potentiometer**

**Check out from stockroom:**

- Portable digital multimeter
- Servo

**Thévenin equivalent**

In the box at right you'll find a review of the steps you use to find a Thévenin equivalent circuit on paper. In this lab you'll do practically the same procedure on the lab bench, but with real-life parts. Instead of calculating and computing  $V_{Th}$  and  $R_{Th}$ , you'll measure  $V_{Th}$  and  $R_{Th}$ .

I want you to make the Thévenin equivalent circuit of the circuit shown below, but first I want you to make an I vs V plot for this circuit. That way when you have the Thévenin circuit you can actually see if they're equivalent.

**Thévenin equivalent**

To calculate the Thévenin equivalent on paper:

- 1) Disregard the load and calculate the open-circuit voltage. This is the Thévenin voltage ( $V_{Th}$ ).
- 2) Zero all the sources. (To zero a voltage source, replace it with a short. To zero a current source, replace it with an open.)
- 3) Compute the total resistance between the load terminals. (DO NOT include the load in this resistance.) This is the Thévenin source resistance ( $R_{Th}$ ).
- 4) Draw the Thévenin equivalent circuit and add your values.

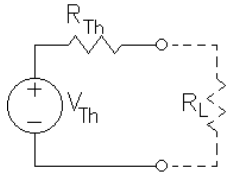

**Part 1, I vs V Plot of original circuit & Measure  $V_{Th}$  :** Set the power supply to 10 V and construct the circuit at right, including an ammeter and voltmeter as shown below it. Record the meter readings with each of the following loads;  $R_L = 0 \Omega$  (short circuit),  $R_L = 100 \Omega$ ,  $R_L = 390 \Omega$ , and finally,  $R_L = \infty \Omega$  (open circuit). The last voltage measurement (with  $R_L$  completely removed) is called the open-circuit voltage and will be your Thévenin voltage ( $V_{th}$ ) (should be ~6.7 V). Draw an I vs V plot in your notebook. (Plot your four sets of measurements, I on vertical axis, V on horizontal.)

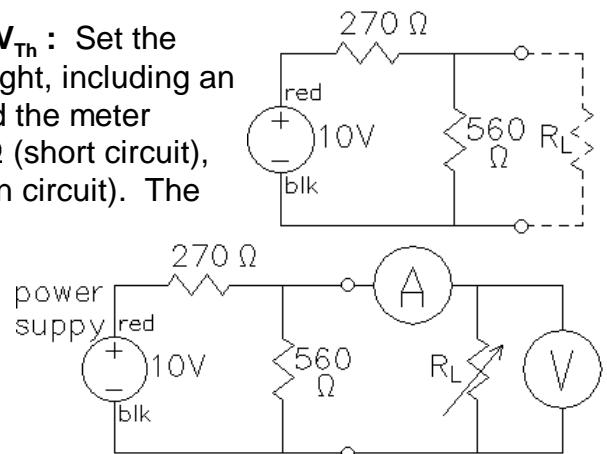

**Part 2, Zero the source:** Disconnect the power supply and replace it with a short. This is the best way to zero the voltage source. You could turn the output down to 0 V, but that method is not as good and not as easy. Incidentally, don't short the supply, place the short in the circuit where the supply *used* to be. (Pull out the wire plugged into the + terminal and push it into the plug already plugged into the - terminal. This effectively disconnects the power supply and replaces it with a short.)

**Part 3 Measure  $R_{Th}$  :** Use an ohmmeter to measure the resistance between the load terminals [ $\sim 180 \Omega$ ]. (Place the ohmmeter across the open terminals where  $R_L$  would be connected.) This is the Thévenin source resistance ( $R_{Th}$ ).

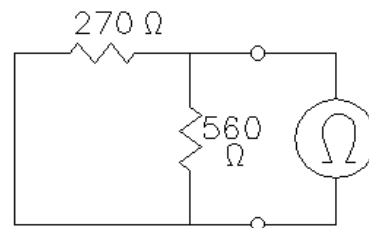

**Part 4 Build Thévenin circuit:**

Build the circuit as shown below. Adjust the power supply to the  $V_{Th}$  value. Adjust the 500  $\Omega$  potentiometer (pot) to the  $R_{Th}$  value with the aid of an ohmmeter. (It's best to put the pot in the bread board, connect the ohmmeter to the center and one of the other terminals, adjust the pot to the right value, and then build the rest of the circuit around it without touching it again.)

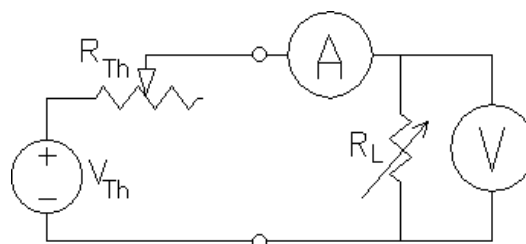

Confirm that this new circuit behaves just like the one it supposedly replaces, that is, take another set of readings with each of the following loads;  $R_L = 0 \Omega$  (short circuit),  $R_L = 100 \Omega$ ,  $R_L = 390 \Omega$ , and  $R_L = \infty \Omega$  (open circuit). Graph these on your I vs V plot and comment on circuit equivalence.

**Calculate and compare:** Finally, just in case you thought this was easier than the calculations, I want you to find the Thévenin equivalent circuit by calculations as well and compare your measured and calculated  $R_{Th}$  and  $V_{Th}$  values. (You may do this later)

**Trim Potentiometers**  
 To get just the right  $R_{th}$ , you'll use an adjustable resistor called a *trim* potentiometer. It's just a smaller version of the potentiometers on the

servo that you are already familiar with.

**Thévenin equivalent of the servo's “Input Position” potentiometer**

Turn off the power switch on the servo and hook it up to the power supply. Adjust the power supply to provide  $\pm 6V$  as you did in the first lab. If you've forgotten how to do this, refer back to the lab handout for lab 1. Turn on the power switch on the servo and make sure that it is functioning properly. When you do something like this you should note it in your lab notebook, sort-of like this: “We hooked power to the servo and made sure it was still working.”

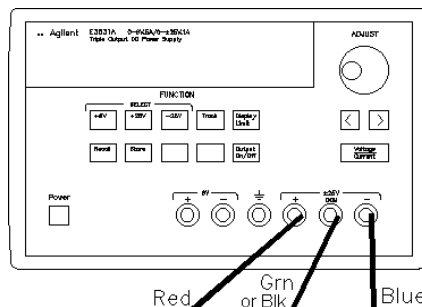

In the last lab you saw how the “Input Position” potentiometer translates shaft position into voltage. Sensors are often modeled as variable sources with a source resistance, just like a

Thévenin equivalent. In this case that's not a perfect model, since the Thévenin resistance ( $R_{th}$ ) also changes a little as you turn the pot. Nevertheless, we'll find a Thévenin equivalent for most clockwise position of the pot and call it good.

Find the wires that go to the motor and pull the plug out of the circuit board. This disconnects the motor so it won't run.

Connect the black lead of a voltmeter to the lead from the power-supply common (the green banana connector on the board). This is the ground of the servo board.

Find the center terminal of the "Input Position" pot, where the yellow is soldered. Connect the red lead of the voltmeter to this point. Measure and record the range of voltages here as you turn the pot through its range of motion. Turn the pot to the fully clockwise position and leave it there. Measure the open-circuit voltage.

Find the jumpers on the circuit board labeled "Connect BNC", and "Connect Pot". Move the "Connect BNC" jumper to the "Connect Resistor" position. This connects a  $10k\Omega$  resistor between the center connection of the pot (yellow lead) and ground making the load resistance  $10k\Omega$  ( $R_L = 10k\Omega$ ). The measured voltage should decrease somewhat. Record this as the loaded voltage ( $V_L$ ). Draw the Thévenin circuit including the load and show the values that you know ( $V_{th}$ ,  $V_L$ , and  $R_L$ ). Calculate the value of Thévenin resistance ( $R_{th}$ ).

This kind of Thévenin or source resistance is often called the "output resistance" or "output impedance" of the sensor. A power source has a "source resistance", a Thévenin equivalent circuit has a "Thévenin resistance", and a signal source has a "output resistance". These all refer to the same basic idea and are used somewhat interchangeably.

Reconnect the motor and turn on the output of the power supply. Make sure that the servo is again functioning properly before you return it to the check-out counter. If it doesn't work, turn it off, check the connections you messed with and/or ask the TA for help.

**More on next page ----->>>**

## Superposition

The E3631A on your bench contains two separate power supplies. Set them to 12V and 6V using the appropriate buttons. Use these to make the circuit shown below.

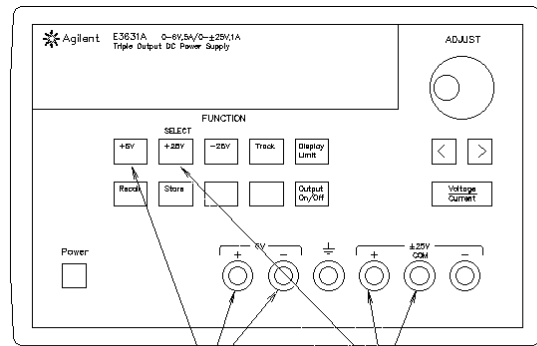
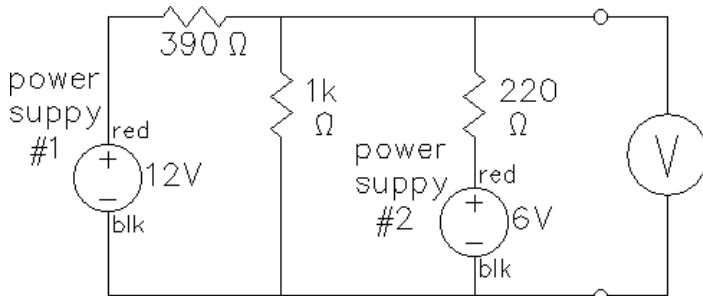

Power supply #2

Power supply #1

With both power supplies on, the voltmeter should read about 7.2V. Record this voltmeter reading as  $V_o$ .

**Part 1, Measure  $V_{o(1)}$  :** “Zero” power supply #2. (Pull out the wire plugged into the + terminal and push it into the plug already plugged into the - terminal. This effectively disconnects the second power supply and replaces it with a short.) Record the new voltmeter reading as  $V_{o(1)}$  [ $\sim 3.8V$ ], the voltage due to source number 1.

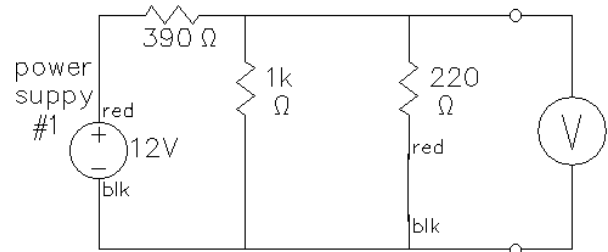

**Part 2, Measure  $V_{o(2)}$  :** Reconnect power supply #2. Now “Zero” power supply #1. Record the new voltmeter reading as  $V_{o(2)}$  [ $\sim 3.4V$ ], the voltage due to source number 2.

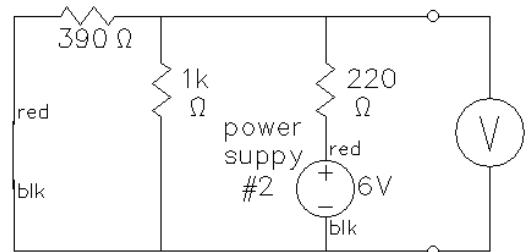

Compare  $V_{o(1)} + V_{o(2)}$  to the  $V_o$  that you originally measured with both power supplies connected. This is superposition. The effects of several sources can be considered separately and added later. Isn't linearity nice?

## Conclude

As always, get your lab instructor to check you off. Write a conclusion in your notebook. Make sure that you touch on each of the subjects in your objectives. Say something about the usefulness of Thévenin and superposition. Discuss the agreement of measurements and calculations. Mention any problems that you encountered in this lab and how you overcame them.

I HAVE A HAMMER!



I CAN PUT THINGS TOGETHER!  
I CAN KNOCK THINGS APART!  
I CAN ALTER MY ENVIRONMENT  
AT WILL AND MAKE AN INCREDIBLE  
DIN ALL THE WHILE!



AH, IT'S GREAT  
TO BE MALE!





**University of Utah**  
**Electrical & Computer Engineering Department**  
ECE 2210/2200 Lab 4  
**Oscilloscope**

A. Stolp, 9/12/12  
Rev 9/22/15, 9/15/16

### Objectives

- 1 Introduce the Oscilloscope and learn some uses.
- 2 Introduce the Signal Generator (also called a Function Generator).
- 3 Observe Audio signals.

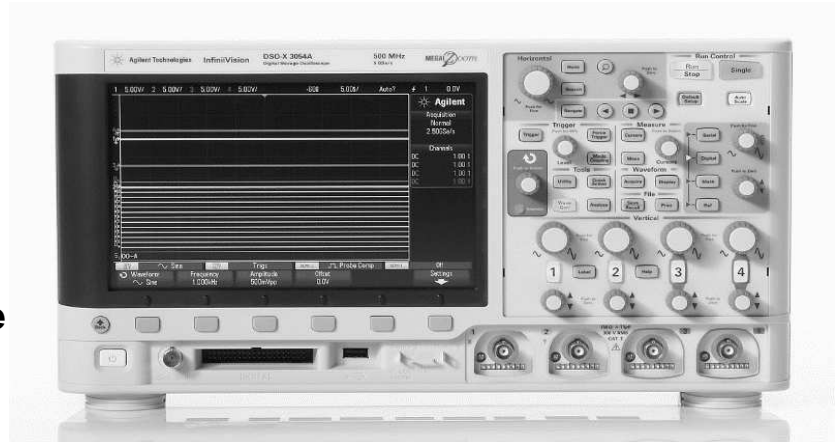

### Parts to be supplied by the student:

- Breadboard and wires
- **Microphone**
- 10 k $\Omega$  resistor

### Check out from window:

- HP 54654A Self-Paced Training Kit for HP 54600-Series Oscilloscopes. We will adapt this for the Agilent 3000 series scopes. (Check the kit to make sure it contains a battery and a Training Guide booklet.)

Also pick up 2 scope probes, a BNC-to-clip cable, a BNC-to-BNC cable and banana-to-clip leads from those hanging in the lab. Pick a bench with an HP 3000 series digital oscilloscope similar to the one pictured above.

### Oscilloscope

In class we've moved beyond simple DC and have been talking about voltages and currents that are functions of time. These waveforms are AC or at least have an AC component. Simple multimeters are adequate to measure DC voltages and currents but can only give some average or effective (RMS) values for AC. Some will also measure frequency and/or peak values but to see the waveform as a function of time you need to use an oscilloscope. Today you will learn to make some basic measurements using the 'scopes found in our lab, but first, familiarize yourself with the scope and its control groups:

1. The screen should be obvious.
2. Right beneath the screen are 6 unlabeled keys. They are "softkeys" and their functions will be shown on the bottom of the screen and will depend on the state of the scope.
3. Under the softkeys is a USB port you may find useful later, and on the left, the power key.
4. The knobs and keys on the right side of the scope are grouped according to function. You will be using controls in the "Vertical", "Horizontal", "Trigger", and Measure" areas as well as some of the others.
5. The inputs to the scope are the 4 BNC connectors below all the controls.

## Turn on the training board and oscilloscope Step by step:



- If you have an account in the Engman computer lab, then you can turn on and log onto the computer on your bench (use the same name and password). Look for the Agilent InfiniVision (or Keysite) scope icon on the desktop and open it if you can find it. The user guide may prove very helpful in the rest of the lab (find the User Guide table and click one of the English 3000 X-series versions)
- Open the Training kit to reveal the Training Guide booklet, the Training board and a battery . Insert the battery in the board.
- Press the pushbutton near the battery holder next to the red LED. Push once to turn on. The LED will light.
- Turn on the oscilloscope with the power button under the screen (left side). The scope should “wake up” in its default state.
- Connect the scope probe to BNC input “1” (the left-most, yellow input). Push it in and twist it clockwise to lock it in place.
- Find the “1x 10x” switch on the business-end of the probe and switch it to the 1x position.
- Connect, the probe ground (short clip lead) to a ground test point on the training signal board.
- Pull back on the sleeve covering the probe tip to reveal the hook at the end and then connect the probe tip to the number 1 test point on the board.
- Find and press the “Autoscale” key near the upper-right corner of the scope. You should now have a display of the test, point 1 waveform. If not, review the instructions above and ask your TA for help if you still can’t get a trace.
- Press the “1” key in the Vertical area to activate the channel 1 softkeys. Hit the 6<sup>th</sup> softkey and then the 2<sup>nd</sup> softkey. Rotate the ↻ knob as needed to let the scope “know” that you’re using a 1x probe. Unfortunately this is not automatic for the scope probe we use. You will have to do this every time you connect a new probe or change the 1x -10x switch position on the probe. If you don’t, your vertical scope readings may be off by a factor of 10 or 100.
- Write a line or two in your notebook about how to turn on the scope, use the “Autoscale” and set the scope for the probe. You will be using this scope in later labs, so make sure your notes are adequate for later reference.
- From here on you will be referring to the Training Guide. You have just performed the “View a signal on the training signal board” in Chapter 1 of the guide. This guide refers to a different scope model and assumes some basic knowledge of oscilloscope controls, functions and terms. I will try to fill you in before you do each section.

## Set up the vertical

- Turn to page 2-4 in the Training Guide. The “Volts/Div” knob is the knob just above the “1” key in the “Vertical” area. The “channel 1 position” knob is the knob just below the “1” key with the ▲ and ▼ symbols above and below it. The “status line” is the top line of text information on the screen. Follow the directions in the guide on pages 2-4 and 2-5. 3. The “Vernier” soft key is called “Fine” on this scope. The position information is closer to the upper right than the bottom left.
- After you’ve finished this section, write the heading of this section (“Set up the vertical”) followed by a line or two in your notebook about what you learned. You should write a similar line or two for all that sections that follow.



### Set up the main time base

- Turn to page 2-6 in the Training Guide. The “Time/Div” knob is the big knob in the Horizontal area and the “Delay” knob is the smaller one.. (Time is the horizontal axis on the scope screen.) This section refers to “triggering” but doesn’t explain this very important concept. The scope shows you volts as a function of time, but at what time? When should the scope start a new trace? These are the questions answered by the triggering function of the scope. Triggering refers to starting a new trace (or “sweep”). Before starting a new sweep from the left side to the right side of the screen, the scope waits to be “triggered”. If the input signal is periodic and the scope triggers on the same point of the waveform each time, then the beam will draw a similar part of the waveform each time and the trace will appear stable. Look at the figures below. The top shows a continuous periodic waveform.

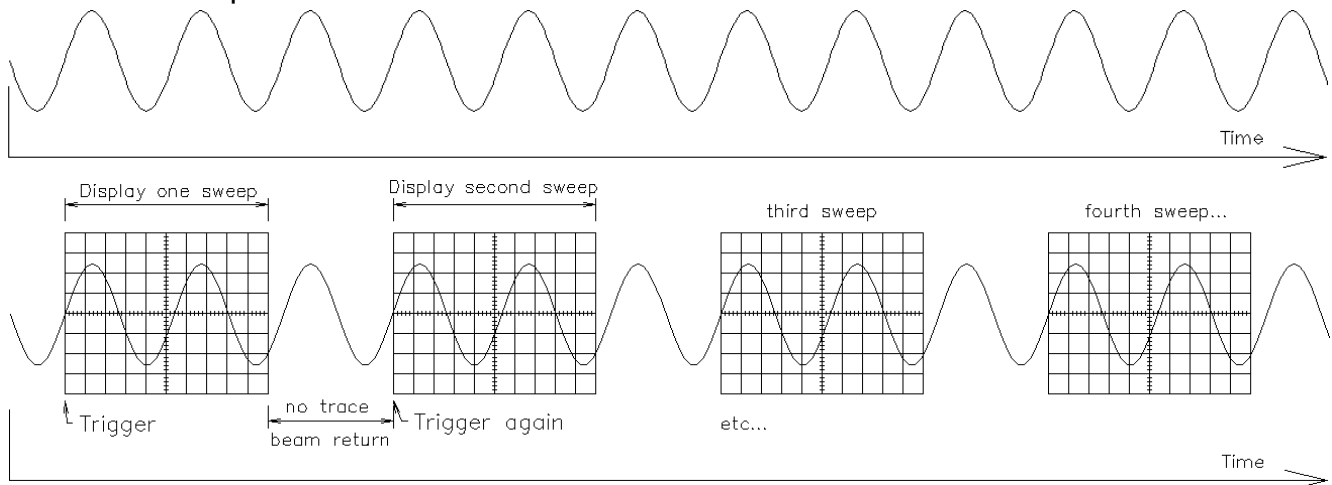

The bottom shows the pieces that will be seen on the scope screen. In this example the scope is triggering at about 0V and a + (upward) slope. How would the trace on the scope screen look different if the scope triggered on the - slope? Explain triggering in your notebook in your own words. If you’re not sure, come back and answer this question after you have a trace on the scope and you’ve had a chance to hit the “Trigger” button followed by hitting the 3<sup>rd</sup> (“Slope”) softkey multiple times to scroll through the slope options.

OK, that’s how an old-fashioned analog scope works– it quite literally waits for the correct trigger before starting a new trace. But this scope is digital. It’s constantly sampling, digitizing and memorizing the input, which means that it can do something no analog scope can do, it can show what the waveform was *before* the trigger. The trigger event is not at the left side of the screen on this digital scope. Instead it is either at the first vertical division (about 1 cm in from the left) or at the center of the screen, depending on how you set the scope.

Now that you understand triggering this section may make some sense. Follow the directions in the guide on pages 2-6 and 2-7. 3. Main/Delayed = Horiz

### Use the delayed time base

- The delayed time base allows you to look at a smaller portion of the main trace in greater detail. It is accessed by zoom (magnifying glass) button in the “Horizontal” section. Turn to page 2-8 in the Training Guide. Do this section starting at step 3. Hit the zoom button again to turn the delayed time base off.

### Set up the normal trigger

- Turn to page 2-9 in the Training Guide. In step 4, use the “Trigger” key and try the different softkey options to see what they do.

### Use time and voltage cursors

- Do the next two sections. Note that the “Cursors” key gives you a “Cursors” softkey to select X1 and X2 instead of t1 and t2 and Y1 and Y2 instead of V1 and V2. Once you’ve hit the “Cursors” softkey once, use the  knob and the “Cursors” knob together to change the cursors quickly and make measurements fast.

### Make voltage and time measurements

- Notice the status line at the top of the screen. It shows the volts per division setting for both channels. Use these values and the division lines on the scope screen to determine the peak-to-peak voltage of each waveform. The status line also shows the time per division setting. Use that to determine the period of either waveform and from that the frequency.
- Now turn to page 2-13 in the Training Guide. Follow the directions there to see how you can let the scope make these measurements for you. Note: your scope has just one “Meas” key instead of individual “Voltage” and “Time” keys.

### Using Trigger Holdoff

- Trigger holdoff is a softkey under the “Mode/Coupling” key. When asked in step 5, use the  knob as needed to get the desired trigger holdoff.
- Turning to page 2-15 and doing the next two sections will give you a much better idea of what triggering is all about and why it is needed to get stable trace. Record the holdoff needed to achieve a stable trace.

### Observe the phase differences between signals





- Turn to page 2-33 and do that section. Note: use the “Trigger” key and the softkeys to change the trigger source to Ch1.
- Turn both knobs on the trainer fully clockwise. Use a combination of the cursors and the “Meas” key to find the phase lag of the lower waveform
- Make sure that you’ve made some comments in your notebook for each section.

Ok, that’s enough for the training board, let’s measure something else with the scope. But first, turn off the training board and disconnect the scope probes from the board. Return the training board now, it may be in demand by other students.

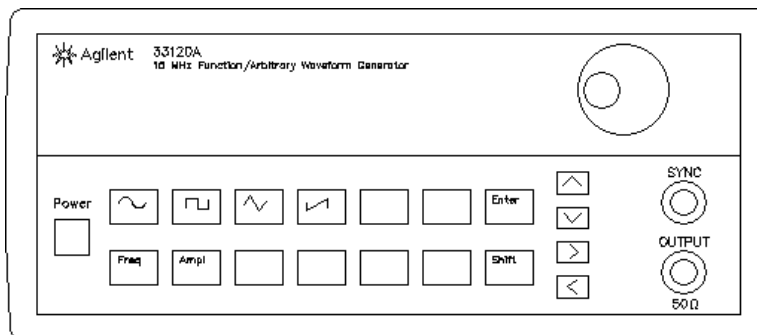
### Function Generator

- Find the HP or Agilent function generator on your bench. Connect the scope to the output of the function generator. You can do this with the BNC-to-clip cable and a scope probe, or connect then directly with a BNC-to-BNC cable.



- Turn on the function generator and let it begin operating. Adjust the scope to look at the trace. Determine the frequency and amplitude (or peak-to-peak) of the signal. Find the frequency and amplitude (or peak-to-peak) values shown by the function generator (you may have to push the “Freq” and/or the “Ampl” buttons to change the display on the function generator). Compare your two sets of values. You should find something strange about the amplitude (or peak-to-peak) values. For reasons I can only describe as “ding-a-ling design”, the function generator actually outputs twice the amplitude it shows, hence, 100 mVpp is actually 200 mVpp. (The ding-a-ling designers made the idiotic assumption that you would always hook their function generator to a 50  $\Omega$  load. Since the output resistance ( $R_S$ ) is also 50  $\Omega$  that would result halving the output. Given that you almost never *actually* hook the function generator to a 50  $\Omega$  load, that was an incredibly stupid assumption on their part.) Please, when you become an engineer and designer, please try to imagine how all the end users will actually use your device and try to anticipate their expectations. If you can’t do this, then please become an “end user” yourself for as long as you can before you finalize your design. Maybe that way you can catch the “ding-a-ling” mistakes before you inflict them on your customers. For example, examine and compare how Apple products operate vs. Microsoft products... you’ll get the idea. Design for the convenience and expectations of the end user– not for the producer. Keysite function generators do not have this problem.
- Hit the  button and observe the effect on the scope. Try the other two waveform shapes as well. Go back to the sinusoid.
- Hit the “Freq” button and change the frequency to 25 Hz. You will need to use a combination of the knob and the  and  buttons. Readjust the scope, measure and compare the frequency.
- Repeat for 12.345 MHz.
- Hit the “Ampl” button and change the displayed Vpp to 240 mVpp. Again, you will need to use a combination of the knob and the  and  buttons. Readjust the scope, measure and compare the Vpp.
- Repeat for 9.5 Vpp.
- Play some more with this combination of instruments and finally turn off the function generator.

### Audio signal

- The microphone in your parts requires some power to function. Set the power supply that you’ve used in previous labs to get +6V.

Connect the +6V to the “+ & output pin” through a 10k $\Omega$  resistor and the “COM” (or “-“ on some supplies) to microphone ground. The scope should be hooked to the “+ & output pin” ( $V_o$  on the schematic) and ground.

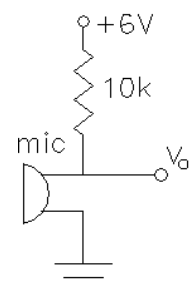
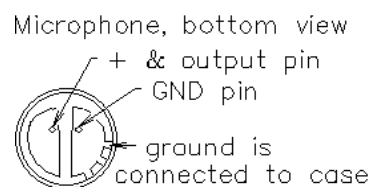

- Hit the Autoscale button. Change the input coupling from DC to AC (1<sup>st</sup> softkey after hitting the number button for the channel you’re using, most likely “1”). Adjust the vertical position to the center of the screen. Don’t hit Autoscale again or the coupling will revert back to DC and the DC will swamp out the much smaller audio signal.
- Play with the scope adjustments (suggestions: vertical ~2 mV/div, horizontal ~ 10 ms/div). Try some different sounds and noises. Does a true audio signal look like the sine waves that we normally use as “signals” in the lab? Comment about the randomness and unpredictability of this signal. see if you can make a sound that

produces something like a sine wave. Note: the triggering will work better if you reject the high frequencies and noise. You can do this with softkeys after you hit the “Mode/Coupling” button in the “Trigger” area.

- Speak into the microphone. Notice that each sweep triggers at the same level and slope, even though the waveform isn’t periodic (each trace is different from the last one). The scope is triggering normally, it can’t help it that the traces don’t overlap nicely after the trigger.

### Frequencies of different sounds

- Make vowel sounds; ahhh, aye, eeee, oooo, eww, etc.. Notice the different frequencies of the different sounds. Try some consonant sounds, like ssssss, shhhh, fffff, or zzzzz. What kinds of sounds are generally higher in frequency?
- Now try to capture some more transient sounds, like t, k, ch, or g. These will be difficult to see, especially with all the noise in the lab. Try “Run/Stop” and “Single” to freeze a single trace that you can look at. Try to freeze and look at the t, k, ch, or g sounds again.
- You should find that the vowel sounds are generally louder and lower in frequency than the consonant sounds. Comment in your notebook. Unfortunately, the consonant sounds are the most important when it comes to understanding speech, so a common complaint of someone who’s lost some of their hearing at higher frequency is, “I can hear, but I can’t understand.”

### Conclusion

This should give you a quick overview of the most important features of the oscilloscope and the function generator as well as give you some practical experience with the microphone. The trainer will help you explore further if you want. Throughout the rest of this semester you will use the scope for many of your measurements and will become much handier with it.

Write a conclusion in your notebook like you’ve done before. Call your lab instructor over to check you off. Be prepared to discuss your measurements, and conclusions and to show off your notebook.

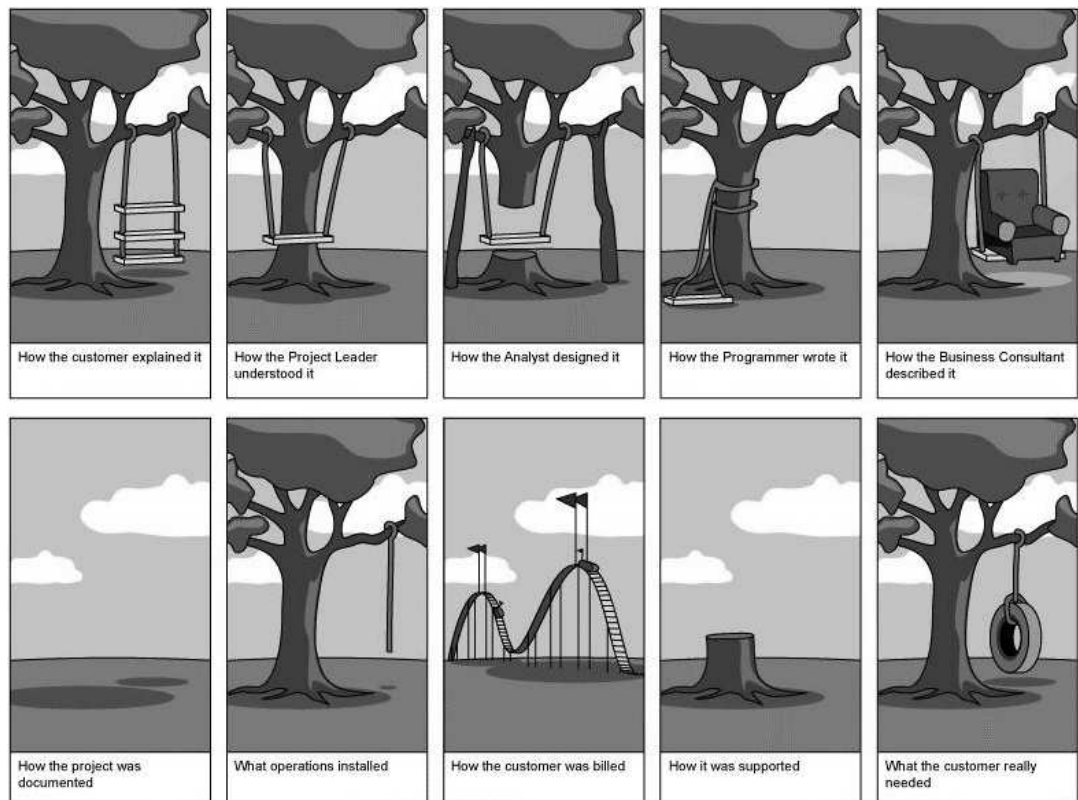

**University of Utah**  
**Electrical & Computer Engineering Department**  
ECE 2210/2200 Lab 5  
**Capacitors**

A. Stolp, 10/4/99  
rev 9/18/12 2/5/13 9/22/13

### Objectives

- 1.) Observe charging and discharging of a capacitor.
- 2.) Measure the time constant of an RC circuit.
- 3.) Observe and measure the frequency dependence of capacitor impedance.
- 4.) Observe the phase relationship of AC voltages and confirm KVL for these voltages.

### Parts to be supplied by the student: (Parts in **bold** are new to this lab)

- 1 k $\Omega$  (brn,blk,red), and **100 k $\Omega$**  (brn,blk,yel) resistors
- **0.1  $\mu$ F** (usually marked 104) and two **47  $\mu$ F capacitors**

### Equipment and materials to be checked out from stockroom:

- Analog BK precision multimeter or similar.

### Capacitors (General background information)

Capacitors with values less than 1  $\mu$ F are usually constructed by layering sheets of metal foil and insulating material. Often these sandwiches are rolled into little cylinders or flattened cylinders. The metal foils are the plates of the capacitor and the insulator is the dielectric. The dielectric material determines the capacitor type (paper, ceramic, polyester, polypropylene, etc.) And its non-ideal characteristics (see Ch 3 of your textbook). The value of a capacitor is proportional to the area of the plates and inversely proportional to the thickness of the dielectric material between them. In general, a capacitor with a larger capacitance value will have to be physically larger as well. Capacitors come in many shapes and a huge range of sizes.

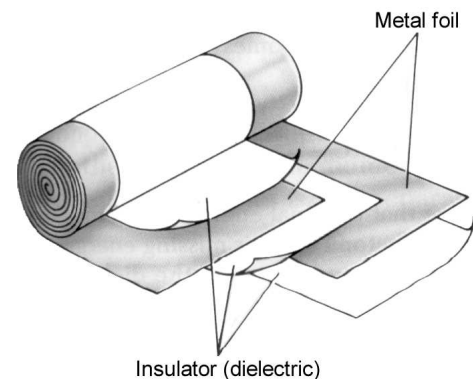

Many small capacitors are marked with numbers like 104K or 471M. The numbers are read like the bands on a resistor— two digits and a multiplier that indicate pico-farads (104 is  $10 \times 10^4$  pF = 0.1  $\mu$ F or 471M is  $47 \times 10^1$  pF). Pico-farads are  $10^{-12}$  farads or  $10^{-6}$   $\mu$ F. The letter indicates the part tolerance (how close should the actual value be to the marking), F =  $\pm 1\%$ , G =  $\pm 2\%$ , J =  $\pm 5\%$ , K =  $\pm 10\%$ , M =  $\pm 20\%$ . See Ch 3 of your textbook for more information.

Capacitors with values greater than 1  $\mu$ F are usually constructed by immersing a roll of metal foil in a conducting liquid (see drawing, at right). A conducting liquid is called an electrolyte and these type of capacitors are called electrolytic capacitors. The foil is one plate and the liquid is the other. The dielectric is a very thin layer of oxide formed on the foil. Because the oxide layer is so thin, electrolytic capacitors can have very large values in relatively small packages. Unfortunately, the oxide dielectric

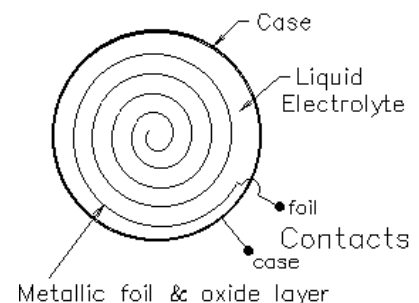

also gives them some other, less desirable, characteristics. Most electrolytic capacitors can only be charged with one polarity. Voltage of the wrong polarity can damage the oxide layer and sometimes even cause the capacitor to blow up. (I can personally vouch for this.) They are difficult to manufacture accurately and their actual value may differ from their claimed value by as much as a factor of two (-50%, +100%). The oxide is not the best of insulators so they can have significant leakage current. Finally, the oxide layer so thin that electrolytic capacitors have relatively low voltage ratings.

## Experiment

Look at your two capacitors. Note that the 47  $\mu\text{F}$  capacitor is larger than the 0.1  $\mu\text{F}$  capacitor, but not 470 times larger. Also notice that the electrolytic capacitor has a voltage rating marked on the package and that one side has a whitish band that indicates polarity. Look for the polarity band, not the lead lengths. If you apply a voltage larger than the rating, or in the wrong polarity, you risk damaging the capacitor, quite possibly making it blow up. **DON'T DO THIS!**

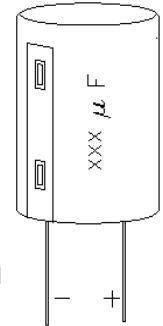

## Charge and Discharge

Set the bench power supply's output to about 14 V. Wire the circuit shown at right using an analog multimeter (switched to 10 V DC range). Note that point A is NOT yet connected to the power supply. If the reading on the voltmeter isn't 0 V, short the capacitor leads together for a second and measure again. Now, while watching the voltmeter, connect point A to the power supply. Notice the rising voltage across the capacitor. Does the voltage seem to follow the expected charging curve for an RC circuit?

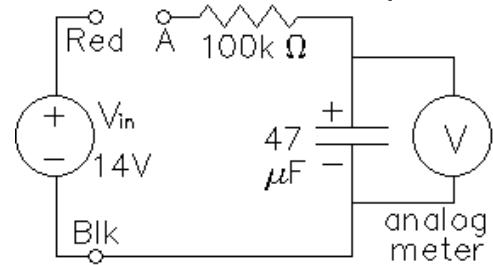

Look at the curve on the next page. It changes quickly at first and ever more slowly as the capacitor approaches its final charge (voltage). Draw a rough sketch of the curve in your lab notebook and comment. Notice that the voltage only rises to about 10 V, not 14 V as you might expect. That's because the meter affects the circuit (see box at right).

Allow the capacitor to charge until the voltage across it changes very slowly and nearly equals 10 V. We'll call this fully charged, although in reality it will never quite reach 10 V. No exponential curve ever really reaches its final value.

While watching the voltmeter, disconnect point A from the red connection of the power supply, allowing the capacitor to discharge through the meter. (Note: because the 100 k $\Omega$  is no longer part of this circuit, the discharge time will be longer than the charge time). Does the voltage seem to follow the expected discharge curve? Sketch the curve in your lab

### Meter Effects

When switched to the 10 V DC setting, the BK meter is equivalent to 250 k $\Omega$  resistor hooked to the circuit. It is rated at 25 k $\Omega$ /V, to find its equivalent resistance you multiply the voltage setting by 25

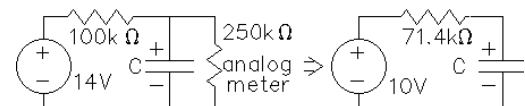

$$k\Omega/V \text{ (} 10V \times 25 \text{ k}\Omega/V = 250 \text{ k}\Omega \text{)}$$

If you were to make a Thévenin equivalent circuit of the power supply, the 100 k $\Omega$  resistor, and the 250 k $\Omega$  internal resistance of the meter, it would look like a 10 V supply with a 71 k $\Omega$  resistor. Hence, the capacitor only charges to 10 V. If you change the range of the meter it will no longer look like a 250 k $\Omega$  resistor and the final capacitor voltage will be different.



notebook and comment. You just made current flow through the meter, even though it was not connected to any power supply or battery. Where did the required energy come from?

### Measure time constant

The charge and discharge equations and curves for an RC circuit are shown below.

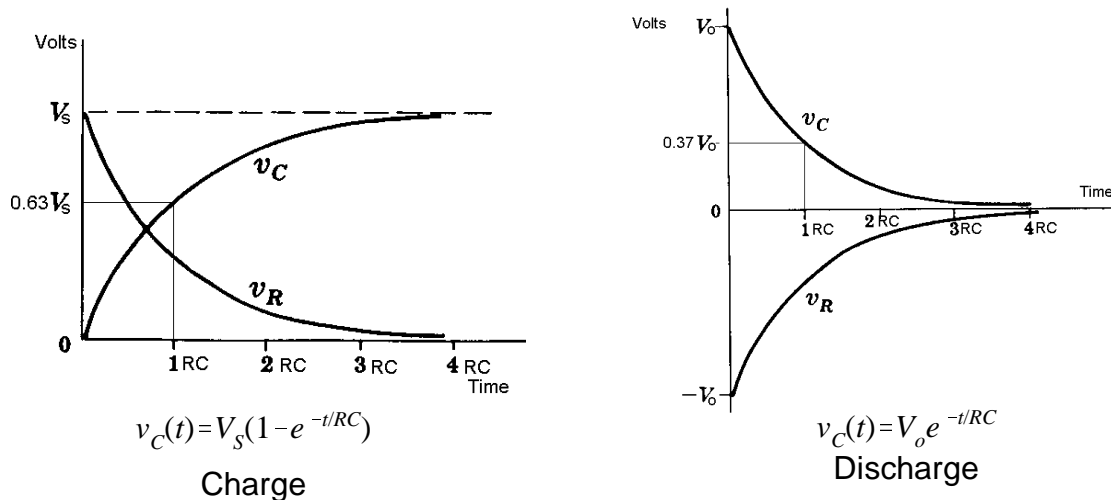

Where  $v_C(t)$  is the capacitor voltage as a function of time,  $V_S$  is the source voltage during charging (The Thévenin voltage for us), and  $V_0$  is the initial voltage across the capacitor at the time that discharge begins.

For RC circuits the quantity  $\tau = RC$  is defined as the “time constant”. When  $t = \tau = RC$  during charging  $v_C(\tau) = 0.63 V_{Th}$ . When  $t = \tau = RC$  during discharge  $v_C(\tau) = 0.37 V_0$ . Calculating  $\tau$  for the charging circuit:  $\tau = 71 \text{ k}\Omega \times 47 \mu\text{F} = 3.4\text{s}$ . During discharge R is only the meter resistance. Calculating  $\tau$  for the discharging circuit:  $\tau = 250 \text{ k}\Omega \times 47 \mu\text{F} = 11.8\text{s}$ .

Repeat the charge and discharge procedure above, only now use a clock, watch, or stopwatch to try and measure the time it takes for the capacitor to charge to 63% of 10 V. Yeah, I know this is tricky and not likely to produce an accurate measurement, but for now, it’s good enough. During discharge, measure the time it takes to discharge to 37% of the fully charged voltage. Compare your measured time constants to those calculated in the previous paragraph.

Quickly repeat this time constant measurement for two 47  $\mu\text{F}$  capacitors in parallel and again for two 47  $\mu\text{F}$  capacitors in series. Comment on series and parallel capacitors.

### RC Filter

The previous sections you looked at the response of an RC circuit to a DC input voltage switched on and off. In this section you’ll see how this circuit behaves when the input voltage is steady-state AC rather than DC. It turns out that the response of the circuit depends on the frequency of the AC input voltage. This type of circuit is commonly called a *filter*. It *passes* some frequencies and *filters out* other frequencies.

Set up the scope and circuit as shown. This is a voltage divider for AC voltages. Use an Agilent or HP 33120A function generator as the signal generator. (It’s internal source

resistance  $R_s$  is shown on the schematic to remind you that it exists). Using the knob and arrow buttons, set the signal generator to  $8 V_{pp}$  (Function generator may have to be set at half this,  $4V_{pp}$ ) at about 100 Hz. (Because the scope screen is often 8 divisions high, a signal like  $8V_{pp}$  that will fill the screen.)

Make sure that both scope channels are set to match the probe settings that you are using (1x or 10x). Measure the peak-to-peak voltage across the capacitor (CH2) at 100 Hz, 300 Hz, 1 kHz, 3 kHz, 10 kHz, 30 kHz, 100 kHz. Make a graph in your notebook to plot these  $V_{pp}$  measurements. If you divide your horizontal axis into 7 even divisions and label them with the 7 frequencies above, then you'll have a close approximation of a logarithmic scale for frequency. That's the way frequencies are normally plotted, on a log scale. Note: If you want to use log paper for your plot, or use a computer to make a log plot, that would be even better.

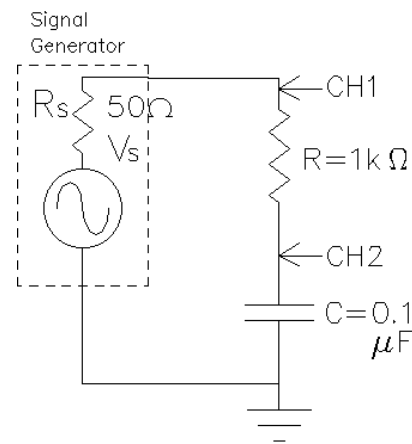
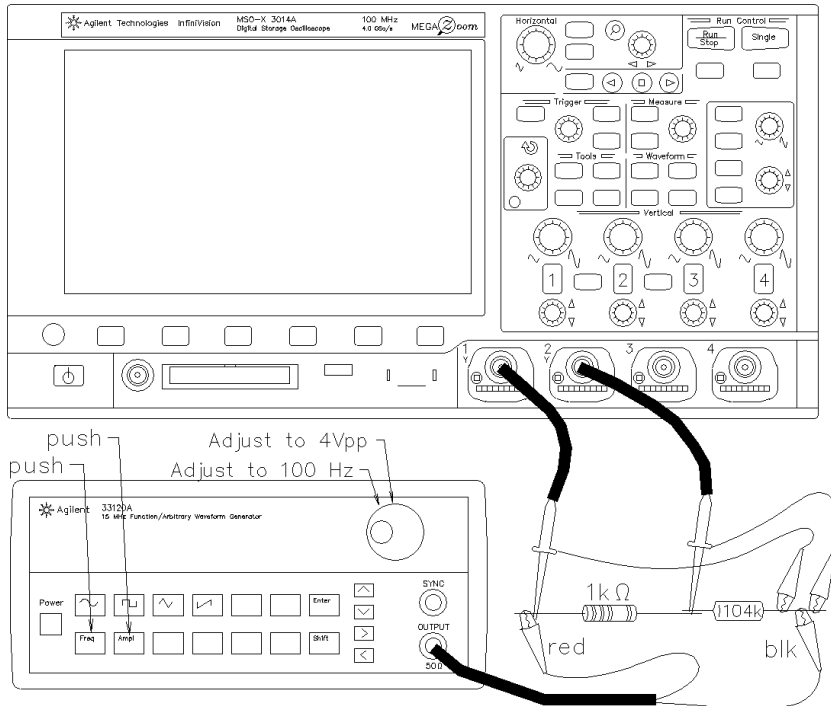

The calculations necessary to determine the theoretical capacitor and resistor voltages are shown in the appendix. Look at the resistor and capacitor peak-to-peak voltages at 3kHz. How can they add up to more than the peak-to-peak source voltage? Is this a violation of Kirchoff's voltage law? Plot the theoretical values (found in the appendix) on the plot you made above. Compare the two lines.

### Observe the phase relationship of AC voltages and confirm KVL for these voltages

Set your signal generator back to 3 kHz. Turn on both scope channels and adjust both Volts/Div knobs to 1V/div (shown at the top of the scope screen).

Use the CH1 vertical position knob (right below the lighted "1" key) to move the tiny ground symbol on the left side of the screen to the center line of the screen. You can also use the little box in the upper-right part of the screen to help. Repeat for the CH2 position. Do the two

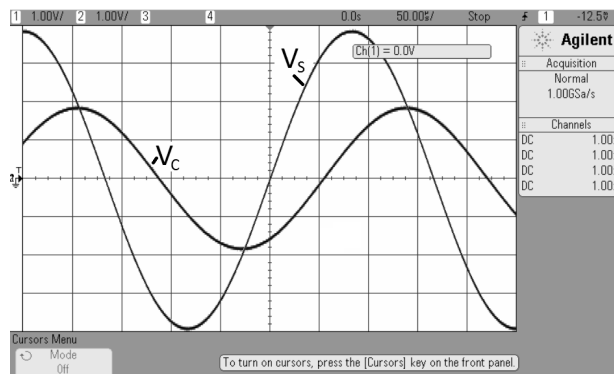

waveforms ( $V_S$  and  $V_C$ ) peak at the same instant in time? If not, then you really can't add the peak-to-peak voltages. You *cannot* add the peaks if they don't happen at the same time! You can, however, add the instantaneous voltage levels and we will do that next.

Hit the "Math" key, then hit the "Operator" softkey and select "- Subtract". Now you should see a third, pink, trace on the screen. This trace shows the difference between the voltages of CH1 and CH2, which is the voltage across the resistor,  $V_R$

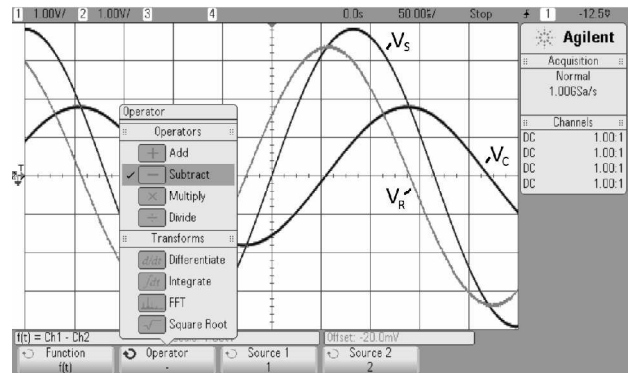

Now you can measure the instantaneous level of all three voltages. I've shown that measurement at a cursor line just to the right of the center line of the scope. I'm using the cursors to help me make measurements (see the Y1 and Y2 at the bottom right of the screen. Make a set of three instantaneous voltage measurements at some time of your choice. Do the two instantaneous levels of  $V_C$  and  $V_R$  add up to the instantaneous level of  $V_S$ ? Check this on at least two other times on the scope. Does Kirchoff's voltage law still hold at each instant? Make a comment in your notebook about your findings.

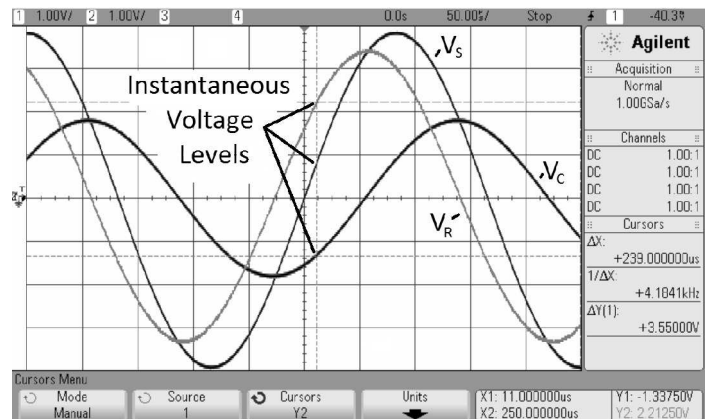

**Conclude** Check-off as usual. Write a conclusion in your notebook. Make sure that you touch on each of the subjects in your objectives.

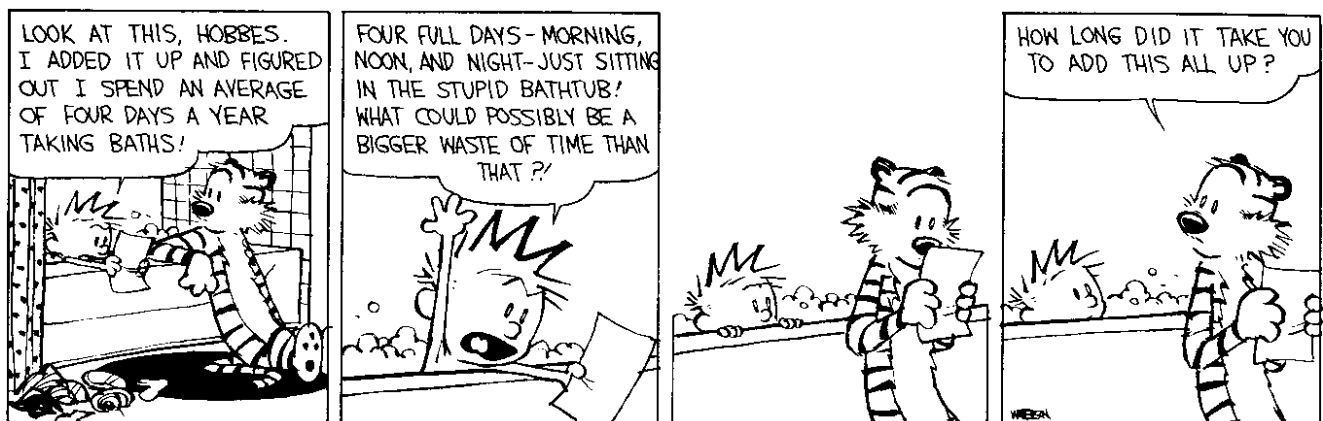

**University of Utah**  
**Electrical & Computer Engineering Department**  
ECE 2210/2200 Lab 6  
**Resonance**

A. Stolp, 10/11/99, rev. 1/6/13

### Objectives

- 1.) Observe, measure and plot the resonance of a series RLC circuit.
- 2.) Observe the effect of R on the “Q”. Observe the resonance of a parallel RLC circuit.
- 3.) Observe oscillation and resonance in the servo system.

### Parts: (Parts in **bold** are new to this lab)

- 100 (brn,blk,brn), 390 (org,wht,brn) and 2 k $\Omega$  (red,blk,red) resistors
- **0.001  $\mu$ F capacitor** (typ. marked 102)
- **Inductor**, 2 to 4 mH (ask for a 3.3 mH blue plastic cylinder marked “●332” or 2.8mH marked “LH233”)

### Equipment and materials from stockroom:

- Servo
- From the post in the lab: 2 10X Oscilloscope probes (If they have switches, make sure they’re set to 10X)

### Inductor Resistance

Measure the resistance of your inductor with an ohmmeter. Ideally this should be 0  $\Omega$ , although you will measure some (hopefully small) value.

### Series RLC Circuit

Construct the circuit shown. Use the A1 button and the “Probe” softkey to let the scope you are using a 10x probe. Turn on channel 2 and repeat.

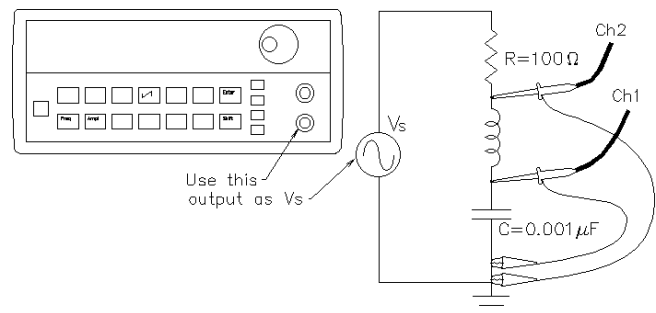

**Find resonance:** Compute the resonant frequency ( $f_0$  in Hz or kHz) of your capacitor and inductor combination (calculated value). Set the function generator to this frequency. Now vary the frequency up and down while looking at  $v_c$  on the scope. The frequency where  $v_c$  is at its maximum is the actual resonant frequency ( $f_0$ ) of your circuit. This can be a little tricky to find with the 33120A because the knob adjusts one digit at a time. To find the true maximum, use the right-arrow button to adjust the lower digits. When you find the frequency where  $v_c$  is greatest, record the frequency shown on the function-generator. Compare the actual  $f_0$  to your calculated  $f_0$  value.



**Plot freq. response:** Take enough measurements of the CH1 and CH2 voltages to plot them both as a function of frequency from  $f_0/8$  to  $8f_0$ . Generally, when a value is plotted as a

function of frequency, the frequency is plotted on a log scale, it makes your curves look

much more symmetric. You may have done this before by plotting 100Hz, 300Hz, 1kHz, 3kHz,... measurements on an evenly divided scale. Another simple way to do this is to take and plot your measurements by factors of two.

Divide your horizontal axis into six divisions (seven marks). Label the center mark with the nearest whole number to  $f_0$ .

Double the frequency for each mark to the right and halve the frequency for each mark to the left. This way the left-most mark will be about  $f_0/8$  and the right-most will be about  $8f_0$ . Wah-lah.., A simple log scale.

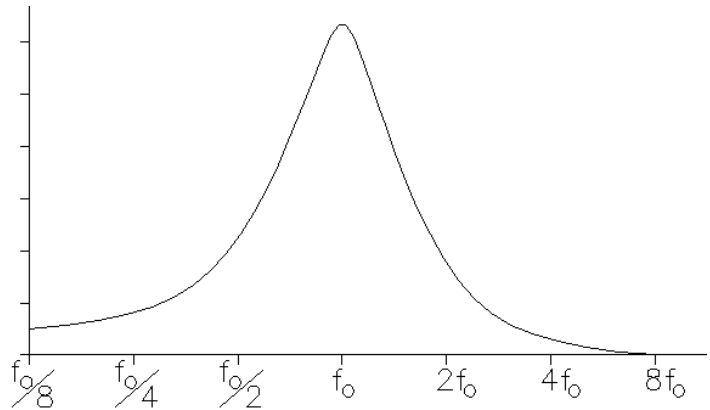

Move CH2 of the scope to measure  $v_s$  (other side of the resistor). Tune your circuit to  $f_0$ . Find the ratio of  $v_c/v_s$ . How can this be greater than 1? Explain.

**Phases:** Adjust the function generator up and down around the resonant frequency while you observe the phase relationship between the two traces. Explain or sketch what you see. Explain why this makes sense. Think in terms of the inductor and capacitor impedances. Which one dominates above the resonant frequency and which one dominates below the resonant frequency? The dominant one will determine the phase of the current in the circuit.

**Different resistor:** Replace the 100  $\Omega$  resistor with a 390  $\Omega$  resistor. Connect CH2 of the scope back to where it was. Take measurements to make the same type of plots as you made before. You may want to plot these on the same horizontal axis, but be sure that all your plotted lines are clearly labeled.

**Q:** Resonant circuits are also characterized by a factor known as the “quality” or “Q” of the circuit. The higher the Q value the sharper the resonant peaks and valleys. Judging by your plots, which of your two circuits has the higher Q? Usually the Q is inversely related to the resistance in the circuit. Comment in your notebook.

### Parallel RLC Circuit

Construct the circuit shown at right, using the same components. Experimentally find the resonant frequency ( $f_0$ ) of this circuit. Is it the same as that of the series circuit? How is resonance different in this circuit? Reset the scope triggering from EXT to INT.

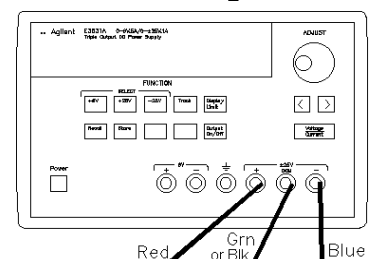
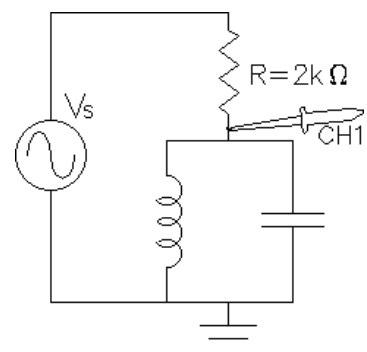

### Oscillation and Resonance of the Servo

Turn off the power switch on the servo and hook it up to the

power supply. Adjust the power supply to provide  $\pm 6V$  as you did in the first lab. If you've forgotten how to do this, refer back to the lab handout for lab 1. Turn on the power switch on the servo and make sure that it is functioning properly. Remember, to comment in your lab notebook that you hooked power to the servo and made sure it was still working.

Hook the scope probe ground clip to the servo ground (the green banana jack where the power supply is connected). Hook the scope probe up to the center wire of the "Motor Position Sensor" potentiometer (yello wire). Remark in your notebook that you hooked the scope up to the "Motor Position" signal.

Set the "Input Position" potentiometer to about center position. Turn up the "Gain" (CW) as far as it will go. If the servo doesn't begin to oscillate on its own, make a slight adjustment to the "Input Position" potentiometer and it should start. If it still doesn't oscillate, turn off the power and adjust the rubber link between the mechanics and the "Motor Position Sensor" to get less friction in the gears. Once you get your servo to oscillate, describe what is happening in your notebook. Adjust the scope to get a repeating trace if you can. Otherwise, hit the "Run/Stop" key to freeze the trace. Find the period and frequency of oscillation.

Now slowly turn down the gain until the oscillations stop. Leave the gain at this "barely stable" position. Hook a BNC-to-BNC cable from the function generator to the servo "SIGNAL" input. Turn on the function generator and adjust the amplitude to 1Vpp (probably have to set to 500mVpp). Listen to the servo motor. Is it trying to move back and forth 1000 times per second? It's not moving very far, is it? Why can't the mechanical system keep up?

Hit the "Run/Stop" key on the scope again if necessary to unfreeze the trace. Turn down the frequency until you get significant movement. Adjust the function generator mVpp to a lower value, say 200mVpp. Lower the frequency farther and try to find a resonance. (You may have to lower the mVpp again to keep the scope trace looking decent. Find the resonant frequency of the servo (where the output is the greatest). Be careful, there may be more than one peak. This seems to be caused by strange dynamics of the rubber link between the mechanics and the "Motor Position Sensor". Make sure that you are on the are biggest peak for true resonance. How does this frequency compare to the natural oscillation frequency that you found earlier? It should be pretty close (but I have to admit, the servos are not very accurate and few people get this resonance to match the oscillation frequency).

**Conclude**  
As always,  
check off  
and write a  
conclusion.

