

Ex. 1 For the circuit shown:a) Find the transfer function v_L .

$$\mathbf{V}_L(s) = \frac{\frac{1}{\frac{1}{Ls} + \frac{1}{R}}}{\frac{1}{\frac{1}{Ls} + \frac{1}{R}} + \frac{1}{Cs}} \cdot \mathbf{V}_S(s)$$

$$= \frac{1}{1 + \frac{1}{Cs} \cdot \left(\frac{1}{Ls} + \frac{1}{R} \right)} \cdot \mathbf{V}_S(s) = \frac{1}{1 + \frac{1}{Cs} \cdot \frac{1}{Ls} + \frac{1}{Cs} \cdot \frac{1}{R}} \cdot \mathbf{V}_S(s) = \frac{s^2}{s^2 + \frac{1}{C \cdot R} \cdot s + \frac{1}{L \cdot C}} \cdot \mathbf{V}_S(s)$$

$$\mathbf{H}(s) = \frac{\mathbf{V}_L(s)}{\mathbf{V}_S(s)} = \frac{s^2}{s^2 + \frac{1}{C \cdot R} \cdot s + \frac{1}{L \cdot C}}$$

$$= \frac{s^2}{s^2 + \frac{3.788 \cdot 10^4}{\text{sec}} \cdot s + \frac{9.091 \cdot 10^9}{\text{sec}^2}}$$

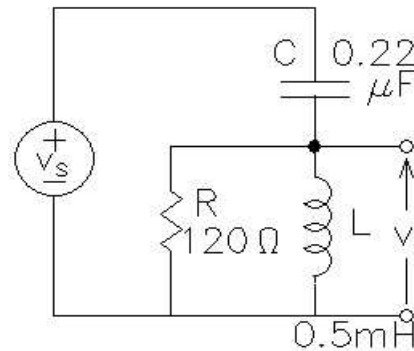

$$R := 120 \cdot \Omega \quad C := 0.22 \cdot \mu\text{F} \quad L := 0.5 \cdot \text{mH}$$

$$\frac{1}{C \cdot R} = 3.788 \cdot 10^4 \cdot \frac{1}{\text{sec}} \quad \frac{1}{L \cdot C} = 9.091 \cdot 10^9 \cdot \frac{1}{\text{sec}^2}$$

b) Find the characteristic equation for this circuit.

$$0 = s^2 + \frac{1}{C \cdot R} \cdot s + \frac{1}{L \cdot C} = s^2 + \frac{3.788 \cdot 10^4}{\text{sec}} \cdot s + \frac{9.091 \cdot 10^9}{\text{sec}^2}$$

Just the denominator set to zero. The solutions of the characteristic equation are the "poles" of the transfer function.

c) Find the differential equation for v_L .

Cross-multiply the transfer function

$$s^2 \cdot \mathbf{V}_S(s) = \left(s^2 + \frac{1}{C \cdot R} \cdot s + \frac{1}{L \cdot C} \right) \cdot \mathbf{V}_L(s)$$

$$s^2 \cdot \mathbf{V}_S(s) = s^2 \cdot \mathbf{V}_L(s) + \frac{1}{C \cdot R} \cdot s \cdot \mathbf{V}_L(s) + \frac{1}{L \cdot C} \cdot \mathbf{V}_L(s)$$

$$\frac{d^2}{dt^2} v_S(t) = \frac{d^2}{dt^2} v_L(t) + \frac{1}{C \cdot R} \cdot \frac{d}{dt} v_L(t) + \frac{1}{L \cdot C} \cdot v_L(t)$$

$$\frac{d^2}{dt^2} v_S(t) = \frac{d^2}{dt^2} v_L(t) + \frac{3.788 \cdot 10^4}{\text{sec}} \cdot \frac{d}{dt} v_L(t) + \frac{9.091 \cdot 10^9}{\text{sec}^2} \cdot v_L(t)$$

d) What are the solutions to the characteristic equation?

$$s_1 = \frac{-3.788 \cdot 10^4}{2} + \frac{1}{2} \cdot \sqrt{(3.788 \cdot 10^4)^2 - 4 \cdot (9.091 \cdot 10^9)} = -1.894 \cdot 10^4 + 9.345 \cdot 10^4 j$$

$$s_2 = \frac{-3.788 \cdot 10^4}{2} - \frac{1}{2} \cdot \sqrt{(3.788 \cdot 10^4)^2 - 4 \cdot (9.091 \cdot 10^9)} = -1.894 \cdot 10^4 - 9.345 \cdot 10^4 j$$

e) What type of response do you expect from this circuit?

The solutions to the characteristic equation are complex so the response will be **underdamped**.

ECE 2210 Lecture 18 notes p2

Ex. 2 Analysis of the circuit shown yields the characteristic equation below. The switch has been in the open position for a long time and is closed (as shown) at time $t = 0$. Find the initial and final conditions and write the full expression for $i_L(t)$, including all the constants that you find.

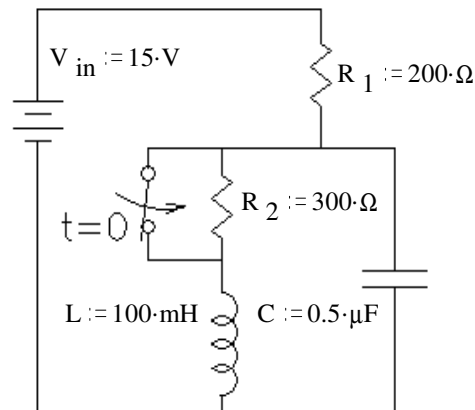

$$s^2 + \left(\frac{1}{C \cdot R_1}\right) \cdot s + \left(\frac{1}{L \cdot C}\right) = 0$$

$$\left(\frac{1}{C \cdot R_1}\right) = 1 \cdot 10^4 \cdot \frac{1}{\text{sec}} \quad \left(\frac{1}{L \cdot C}\right) = 2 \cdot 10^7 \cdot \frac{1}{\text{sec}^2}$$

$$s^2 + 10000 \cdot \frac{1}{\text{sec}} \cdot s + 2 \cdot 10^7 \cdot \frac{1}{\text{sec}^2} = 0$$

$$s_1 := \left[\frac{-10000}{2} + \frac{1}{2} \cdot \sqrt{(10000)^2 - 4 \cdot (2 \cdot 10^7)} \right] \cdot \text{sec}^{-1}$$

$$s_2 := \left[\frac{-10000}{2} - \frac{1}{2} \cdot \sqrt{(10000)^2 - 4 \cdot (2 \cdot 10^7)} \right] \cdot \text{sec}^{-1}$$

$$s_1 = -2764 \cdot \text{sec}^{-1}$$

$$s_2 = -7236 \cdot \text{sec}^{-1}$$

s_1 and s_2 are both real and distinct, overdamped

Find the initial conditions:

Before the switch closed, the inductor current was: $\frac{15\text{V}}{R_1 + R_2} = 30\text{mA} = i_L(0)$

Before the switch closed, the capacitor voltage was: $\frac{R_2}{R_1 + R_2} \cdot (15\text{V}) = 9\text{V} = v_C(0)$

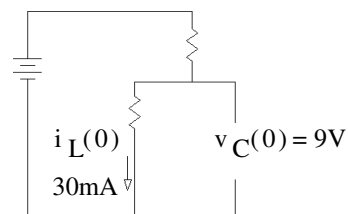

When the switch is closed, the inductor is suddenly in parallel with the capacitor, and:

$$v_L(0) = v_C(0)$$

$$\frac{d}{dt} i_L(0) = \frac{1}{L} \cdot v_L(0) =$$

$$\frac{1}{L} \cdot 9\text{V} = 90 \cdot \frac{\text{A}}{\text{sec}}$$

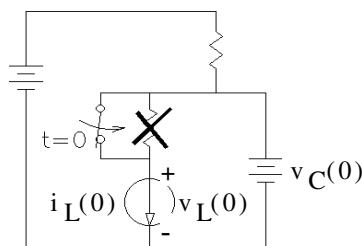

Find the final condition:

$$i_L(\infty) = \frac{15\text{V}}{R_1} = 75\text{mA}$$

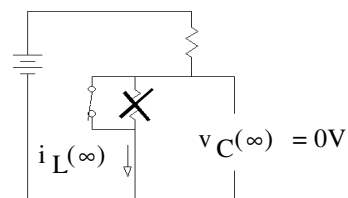

General solution for the overdamped condition: $i_L(t) = i_L(\infty) + B \cdot e^{s_1 t} + D \cdot e^{s_2 t}$

Initial conditions: $i_L(0) = \frac{15\text{V}}{R_1 + R_2} = i_L(\infty) + B + D$, so $B = i_L(0) - i_L(\infty) - D = 30\text{mA} - 75\text{mA} - D = -45\text{mA} - D$

$$\frac{d}{dt} i_L(0) = 90 \cdot \frac{\text{A}}{\text{sec}} = s_1 \cdot B + s_2 \cdot D = s_1 \cdot (-45\text{mA} - D) + s_2 \cdot D = s_1 \cdot (-45\text{mA}) - s_1 \cdot D + s_2 \cdot D$$

solve for D & B: $D := \frac{90 \cdot \frac{\text{A}}{\text{sec}} - s_1 \cdot (-45\text{mA})}{-s_1 + s_2}$

$$D = 7.69\text{mA}$$

$$B := -45\text{mA} - D$$

$$B = -52.7\text{mA}$$

Plug numbers back in: $i_L(t) := 75\text{mA} - 52.7\text{mA} \cdot e^{-2764t} + 7.69\text{mA} \cdot e^{-7236t}$

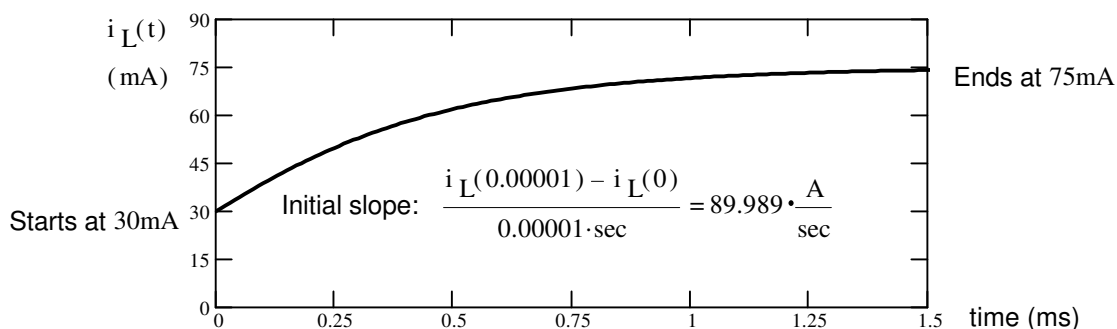

Ex. 3

Analysis of the circuit shown yields the characteristic equation and s values below. The switch has been in the closed position for a long time and is opened (as shown) at time $t = 0$. Find the initial and final conditions and write the full expression for $v_C(t)$, including all the constants.

$$0 = s^2 + \frac{R_1}{L} \cdot s + \frac{1}{LC}$$

$$s_1 := (-250 + 10^4 \cdot j) \cdot \frac{1}{\text{sec}}, \quad s_2 := (-250 - 10^4 \cdot j) \cdot \frac{1}{\text{sec}}$$

Solution: $\alpha := -250 \cdot \frac{1}{\text{sec}}$ $\omega := 10000 \cdot \frac{\text{rad}}{\text{sec}}$

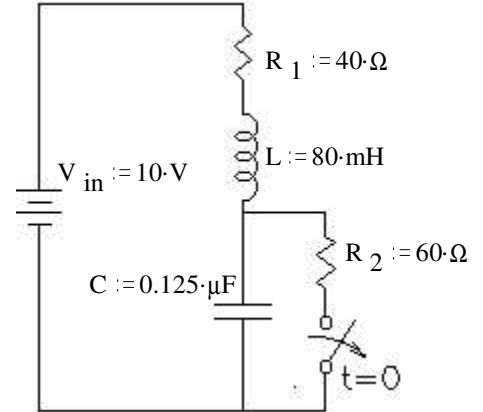

Initial conditions:

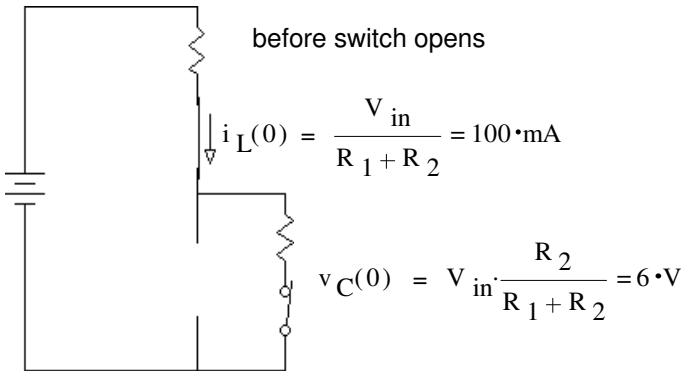

just after the switch opens

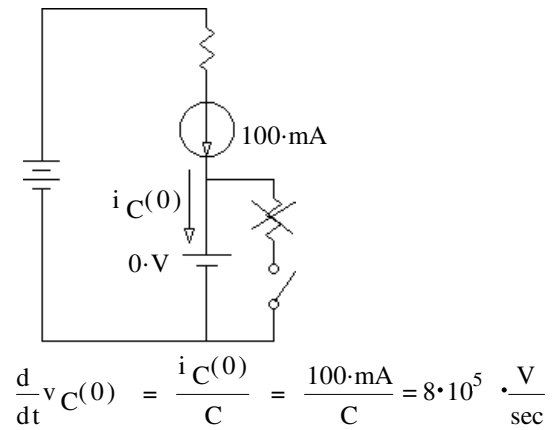

Find final condition:

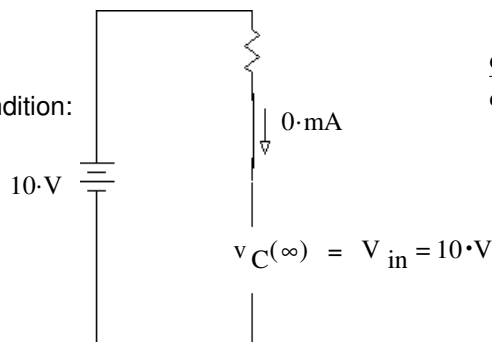

Find constants: $v_C(0) = v_C(\infty) + B$ $B = v_C(0) - v_C(\infty)$ $B := 6 \cdot \text{V} - 10 \cdot \text{V}$ $B = -4 \cdot \text{V}$

$$\frac{d}{dt} v_C(0) = \alpha \cdot B + D \cdot \omega$$

$$D := \frac{8 \cdot 10^5 \cdot \frac{\text{V}}{\text{sec}} - \alpha \cdot B}{\omega}$$

$$D = 79.9 \cdot \text{V}$$

Write the full expression for $v_C(t)$, including all the constants that you find.

$$v_C(t) = e^{\alpha t} \cdot (B \cdot \cos(\omega \cdot t) + D \cdot \sin(\omega \cdot t)) + v_C(\infty)$$

$$v_C(t) := e^{-250t} \cdot (-4 \cdot \text{V} \cdot \cos(10^4 \cdot t) + 79.9 \cdot \text{V} \cdot \sin(10^4 \cdot t)) + 10 \cdot \text{V}$$

$$\sqrt{D^2 + B^2} = 80 \cdot \text{V}$$

$v_C(t)$
(volts)

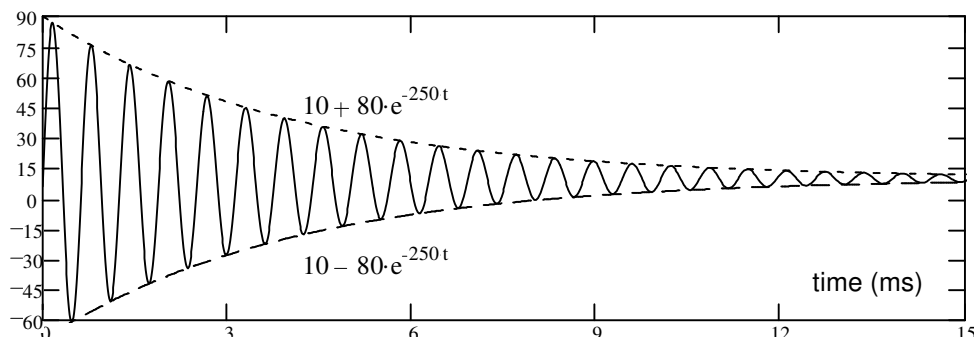

ECE 2210 Lecture 18 notes p4

Ex. 4 Ex.3 Backwards, switch closes at $t = 0$

Characteristic eq.: $0 = s^2 + \left(\frac{1}{C \cdot R_2} + \frac{R_1}{L}\right) \cdot s + \left(1 + \frac{R_1}{R_2}\right) \cdot \frac{1}{L \cdot C}$

$s_1 := -1.257 \cdot 10^3 \cdot \frac{1}{\text{sec}}$ $s_2 := -1.326 \cdot 10^5 \cdot \frac{1}{\text{sec}}$

Initial conditions, same as Ex.3 final:

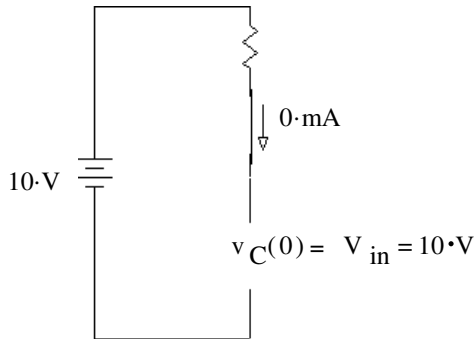
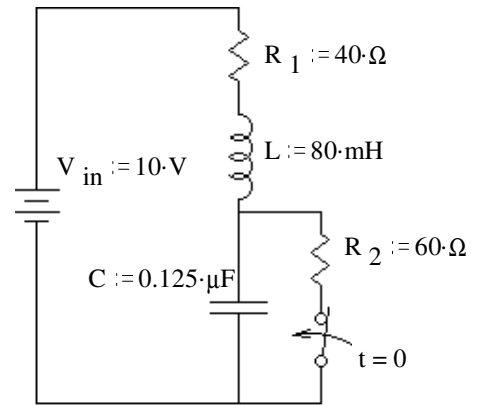

Find final condition:

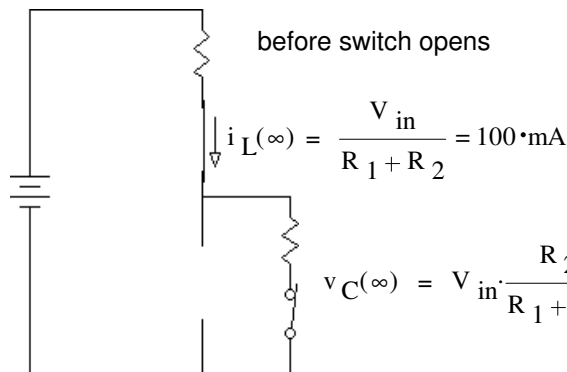

just after the switch opens

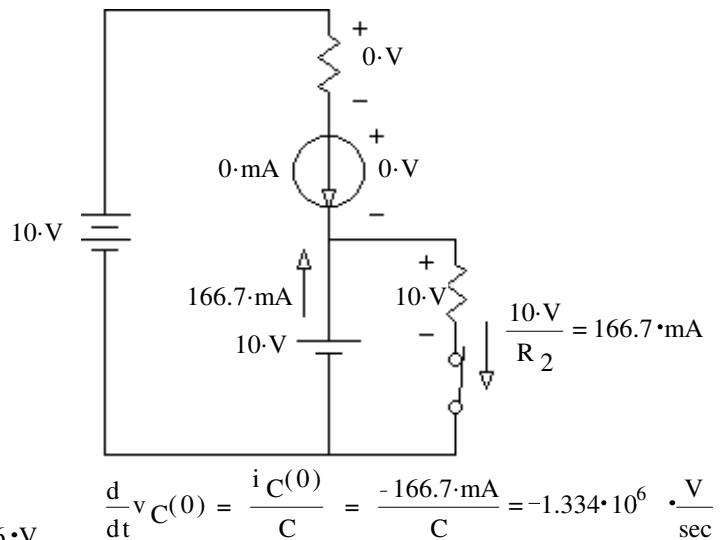

Find constants: $v_C(0) = v_C(\infty) + B + D$, so $B = v_C(0) - v_C(\infty) - D = 10 \cdot \text{V} - 6 \cdot \text{V} - D = 4 \cdot \text{V} - D$

$$\frac{d}{dt} v_C(0) = -1.334 \cdot 10^6 \cdot \frac{\text{V}}{\text{sec}} = s_1 \cdot B + s_2 \cdot D = s_1 \cdot (4 \cdot \text{V} - D) + s_2 \cdot D = s_1 \cdot (4 \cdot \text{V}) - s_1 \cdot D + s_2 \cdot D$$

$$D := \frac{-1.334 \cdot 10^6 \cdot \frac{\text{V}}{\text{sec}} - s_1 \cdot (4 \cdot \text{V})}{-s_1 + s_2}$$

$D = 10.12 \cdot \text{V}$ $B = 4 \cdot \text{V} - D$ $B = -6.12 \cdot \text{V}$

$$v_C(t) := 6 \cdot \text{V} - 6.12 \cdot \text{V} \cdot e^{-1257t} + 10.12 \cdot \text{V} \cdot e^{-132600t}$$

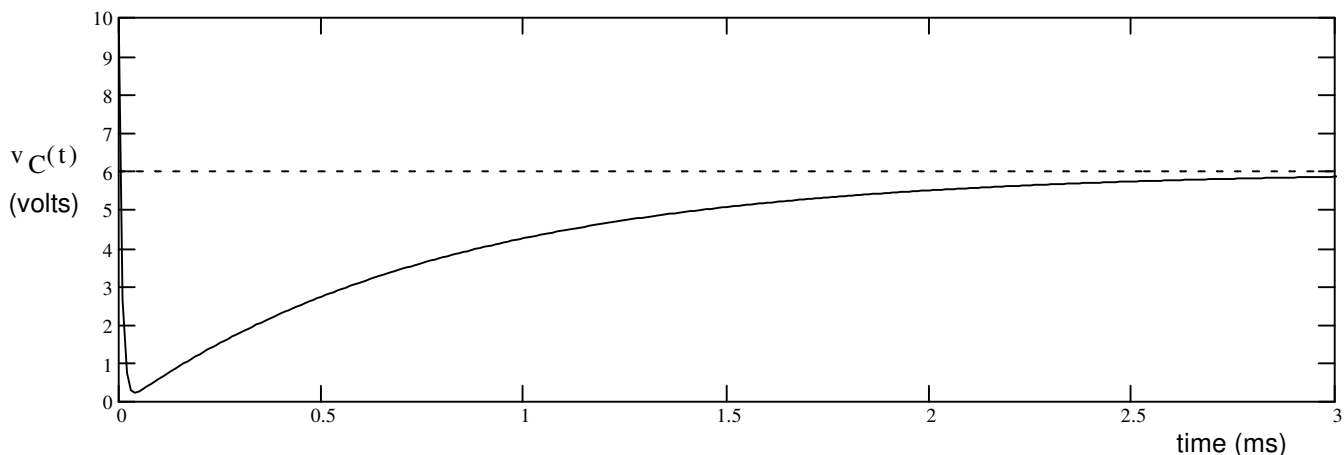

Ex. 5 Analysis of a circuit (not pictured) yields the characteristic equation below.

$$0 = s^2 + 400 \cdot s + 400000$$

$$R := 80 \cdot \Omega$$

$$L := 20 \cdot \text{mH}$$

$$C := 2 \cdot \mu\text{F}$$

Further analysis yields the following initial and final conditions:

$$i_L(0) = 120 \cdot \text{mA}$$

$$v_L(0) = -3 \cdot \text{V}$$

$$v_C(0) = 7 \cdot \text{V}$$

$$i_C(0) = -80 \cdot \text{mA}$$

$$i_L(\infty) = 800 \cdot \text{mA}$$

$$v_L(\infty) = 0 \cdot \text{V}$$

$$v_C(\infty) = 12 \cdot \text{V}$$

$$i_C(\infty) = 0 \cdot \text{mA}$$

Write the full expression for $i_L(t)$, including all the constants that you find.

$$i_L(t) = ?$$

Solution:

$$\frac{400}{2} = 200$$

$$\frac{\sqrt{400^2 - 4 \cdot 400000}}{2} = 600j$$

$$s_1 := (-200 + 600j) \cdot \frac{1}{\text{sec}}$$

$$\text{and } s_2 := (-200 - 600j) \cdot \frac{1}{\text{sec}}$$

$$\alpha := \text{Re}(s_1)$$

$$\alpha = -200 \cdot \text{sec}^{-1}$$

$$\omega := \text{Im}(s_1)$$

$$\omega = 600 \cdot \text{sec}^{-1}$$

$$\text{Initial slope: } \frac{d}{dt} i_L(0) = \frac{v_L(0)}{L} = \frac{-3 \cdot \text{V}}{L} = -150 \cdot \frac{\text{A}}{\text{sec}}$$

General solution for the underdamped condition: $i_L(t) = i_L(\infty) + e^{\alpha t} \cdot (B \cdot \cos(\omega \cdot t) + D \cdot \sin(\omega \cdot t))$

$$\text{Find constants: } i_L(0) = i_L(\infty) + B$$

$$B = i_L(0) - i_L(\infty)$$

$$B := 120 \cdot \text{mA} - 800 \cdot \text{mA}$$

$$B = -680 \cdot \text{mA}$$

$$\frac{d}{dt} i_L(0) = \alpha \cdot B + D \cdot \omega$$

$$D := \frac{-150 \cdot \frac{\text{A}}{\text{sec}} - \alpha \cdot B}{\omega}$$

$$D = -476.667 \cdot \text{mA}$$

Write the full expression for $i_L(t)$, including all the constants that you find.

$$i_L(t) := 800 \cdot \text{mA} + e^{-200t} \cdot (-680 \cdot \text{mA} \cdot \cos(600 \cdot t) - 477 \cdot \text{mA} \cdot \sin(600 \cdot t))$$

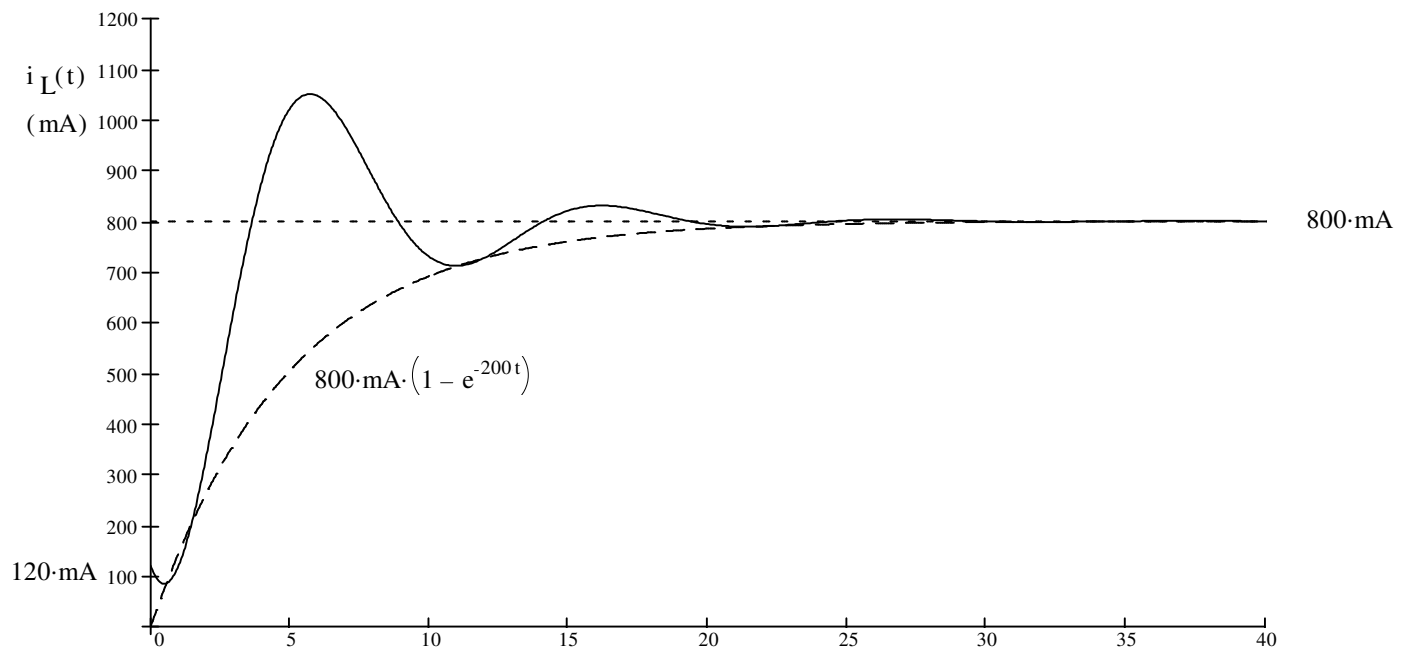

Ex. 6

Analysis of a circuit (not pictured) yields the characteristic equation below.

$$0 = s^2 + 800 \cdot s + 160000$$

$$R := 60 \cdot \Omega$$

$$L := 350 \cdot \text{mH}$$

$$C := 20 \cdot \mu\text{F}$$

$$V_{\text{in}} := 12 \cdot \text{V}$$

Further analysis yields the following initial and final conditions:

$$i_L(0) = 30 \cdot \text{mA}$$

$$v_L(0) = -7 \cdot \text{V}$$

$$v_C(0) = 5 \cdot \text{V}$$

$$i_C(0) = 70 \cdot \text{mA}$$

$$i_L(\infty) = 90 \cdot \text{mA}$$

$$v_L(\infty) = 0 \cdot \text{V}$$

$$v_C(\infty) = 12 \cdot \text{V}$$

$$i_C(\infty) = 0 \cdot \text{mA}$$

Write the full expression for $i_L(t)$, including all the constants that you find. $i_L(t) = ?$

Include **units** in your answer

Solution:

$$\frac{-800 \pm \sqrt{800^2 - 4 \cdot 160000}}{2} = -400$$

$$s_1 := -400 \cdot \frac{1}{\text{sec}}$$

$$s_2 := -400 \cdot \frac{1}{\text{sec}}$$

s_1 and s_2 are the same,
critically damped

Initial slope: $\frac{d}{dt}i_L(0) = \frac{v_L(0)}{L} = \frac{-7 \cdot \text{V}}{L} = -20 \cdot \frac{\text{A}}{\text{sec}}$

General solution for the critically damped condition: $i_L(t) = i_L(\infty) + B \cdot e^{s_1 t} + D \cdot t \cdot e^{s_2 t}$

Find constants: $i_L(0) = i_L(\infty) + B$

$$B = i_L(0) - i_L(\infty)$$

$$B := 30 \cdot \text{mA} - 90 \cdot \text{mA}$$

$$B = -60 \cdot \text{mA}$$

$$\frac{d}{dt}i_L(0) = B \cdot s_1 + D$$

$$D := -20 \cdot \frac{\text{A}}{\text{sec}} - B \cdot s_1$$

$$D = -44 \cdot \frac{\text{A}}{\text{sec}}$$

Write the full expression for $i_L(t)$,
including all the constants that you find.

$$i_L(t) := 90 \cdot \text{mA} - 60 \cdot \text{mA} \cdot e^{-\frac{400}{\text{sec}} t} - 44 \cdot \frac{\text{A}}{\text{sec}} \cdot t \cdot e^{-\frac{400}{\text{sec}} t}$$

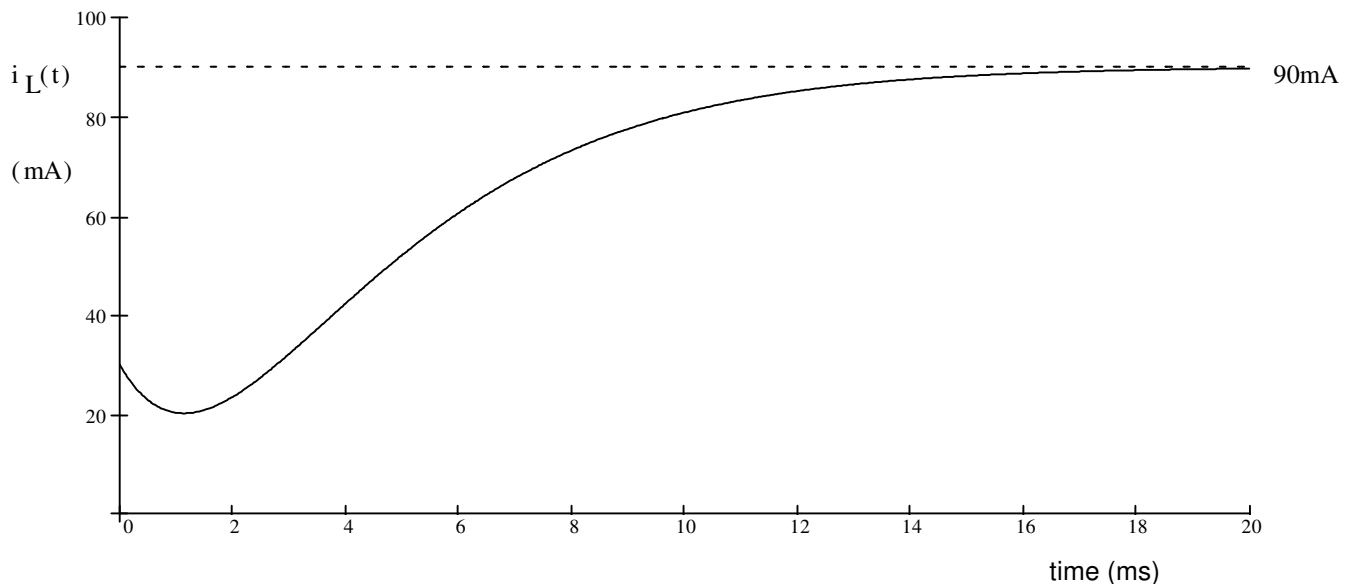

ECE 2210 Lecture 19 notes Second order Transient example & Systems

A. Stolp
11/1/06

Ex 1. The switch at right has been in the open position for a long time and is closed (as shown) at time $t = 0$.

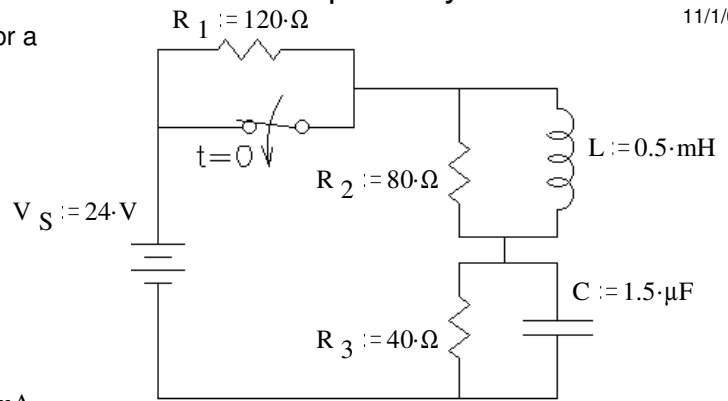

a) What are the final conditions of i_L and the v_C ?

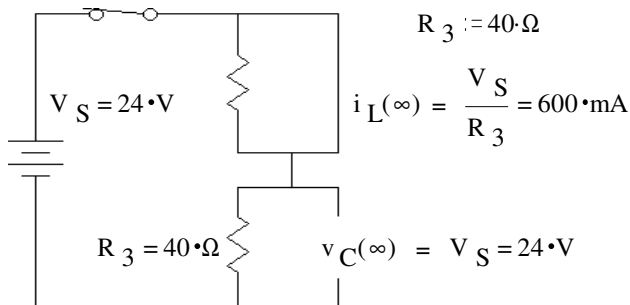

b) Find the initial condition and initial slope of i_L so that you could find all the constants in $i_L(t)$.

Don't find $i_L(t)$ or it's constants, just the initial conditions.

Before the switch closes

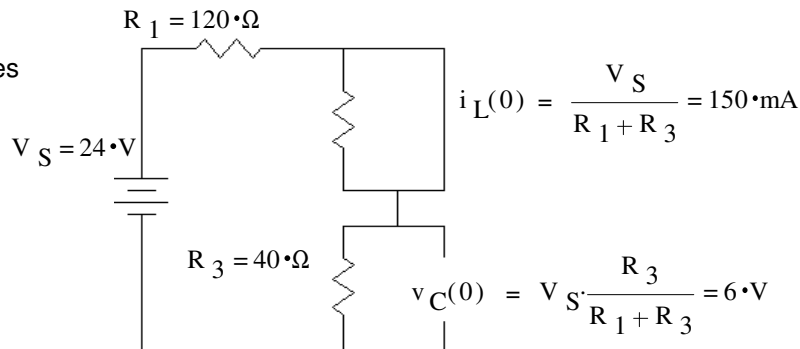

Just after the switch closes:

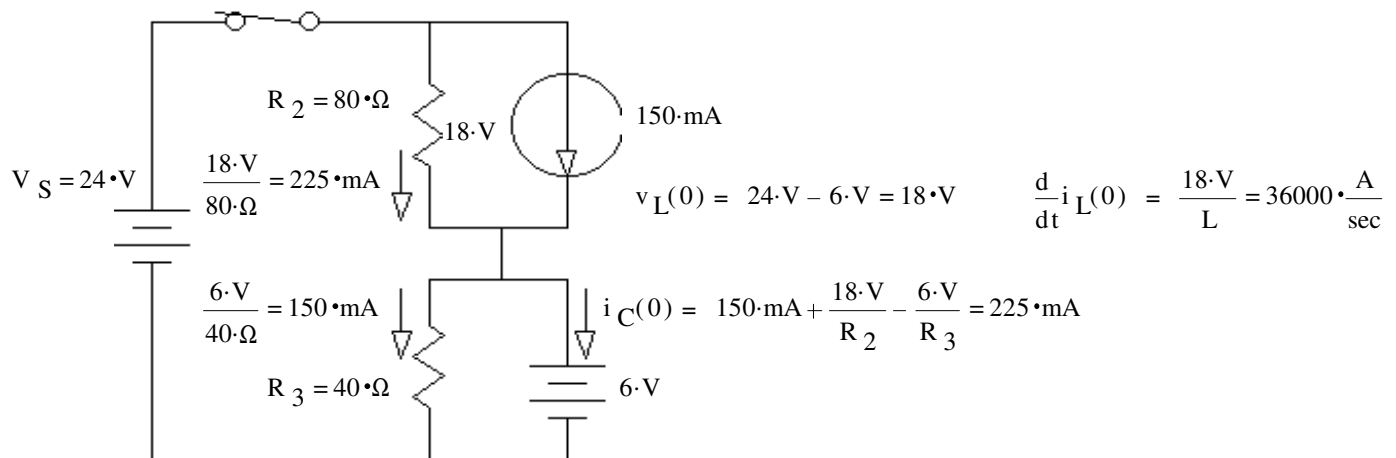

c) Find the initial condition and initial slope of v_C so that you could find all the constants in $v_C(t)$.

Don't find $v_C(t)$ or it's constants, just the initial conditions.

$$v_C(0) = V_S \cdot \frac{R_3}{R_1 + R_3} = 6 \cdot V$$

$$\frac{d}{dt} v_C(0) = \frac{225 \cdot mA}{C} = 150000 \cdot \frac{V}{sec}$$

Systems

Now that we've developed the concept of the transfer function, we can now develop system block diagrams using blocks which contain transfer functions.

Consider a circuit:

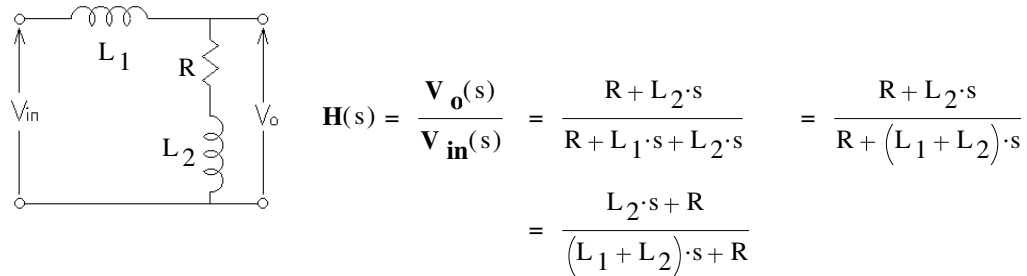

This could be represented in as a block operator:

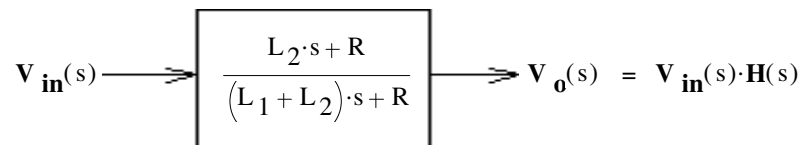

Transfer functions can be written for all kinds of devices and systems, not just electric circuits and the input and output do not have to be similar. For instance, the potentiometers used to measure angular position in the lab servo can be represented like this:

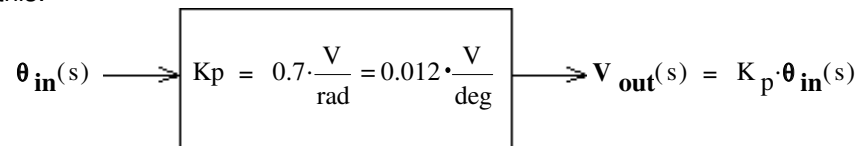

In general:

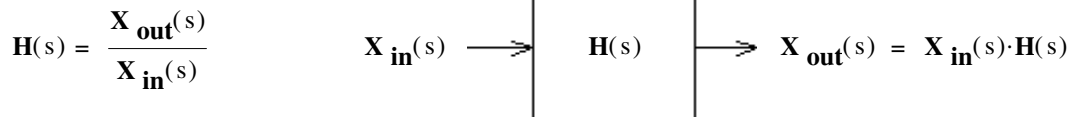

X_{in} and X_{out} could be anything from small electrical signals to powerful mechanical motions or forces.

Two blocks with transfer functions $A(s)$ and $B(s)$ in a row would look like this:

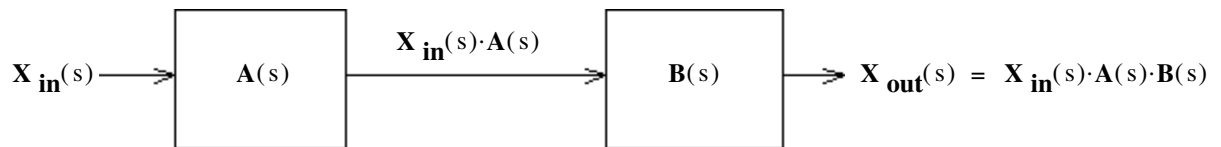

The two blocks could be replaced by a single equivalent block:

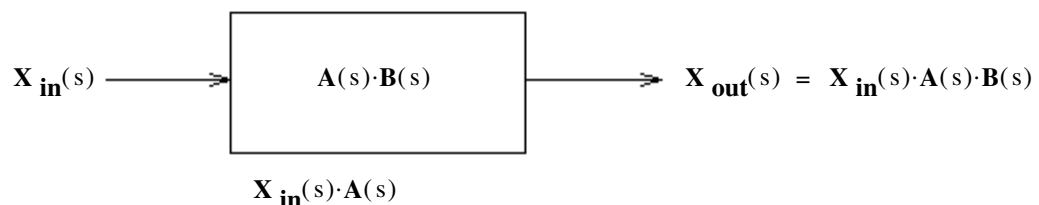

ECE 2210 Lecture 19 notes p3

Summer blocks can be used to add signals:

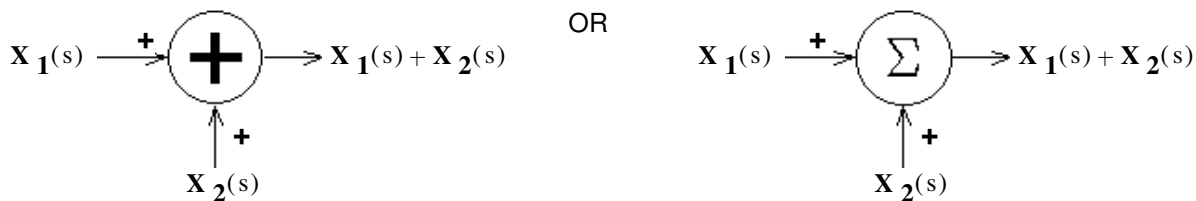

or subtract signals:

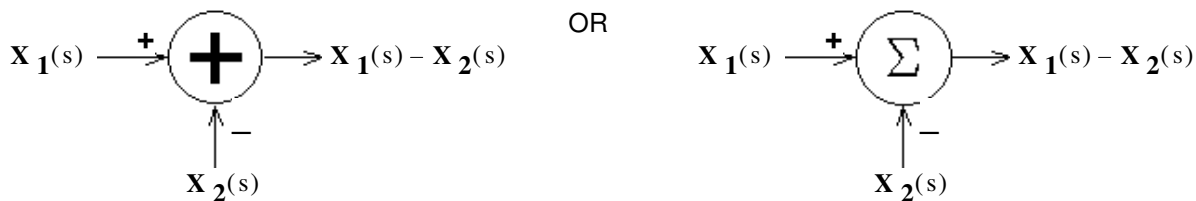

A feedback loop system is particularly interesting and useful:

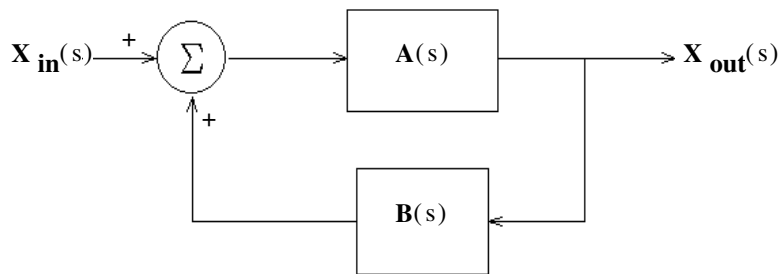

The entire loop can be replaced by a single equivalent block:

Note that I've begun to drop the (s)

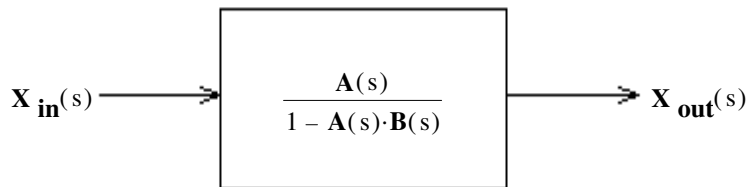
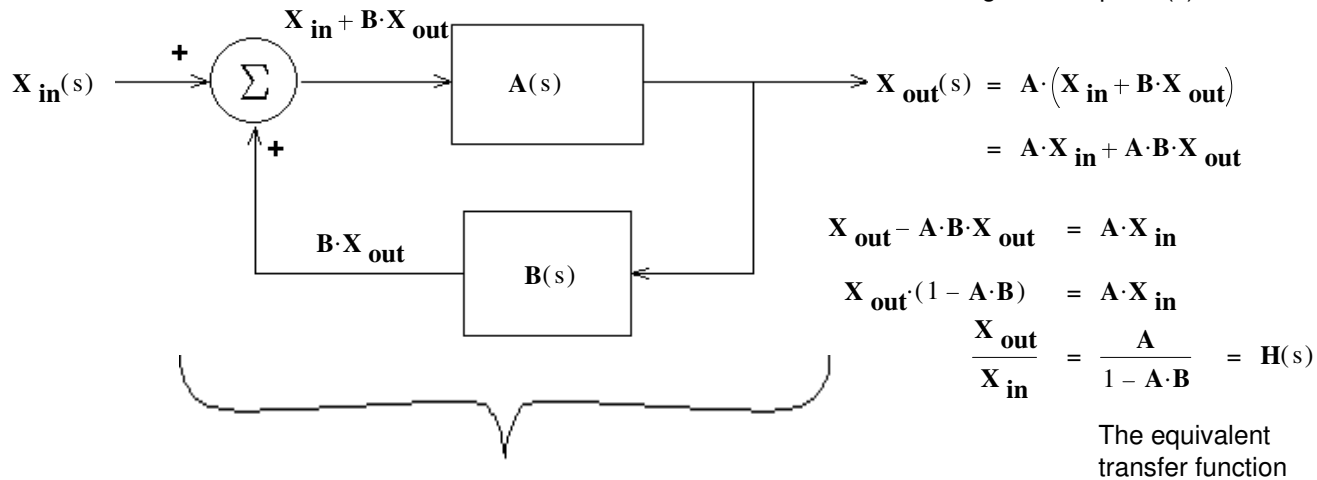

$A(s) \cdot B(s)$ is called the "loop gain" or "open loop gain"

ECE 2210 Lecture 19 notes p4

Negative feedback is more common and is used as a control system:

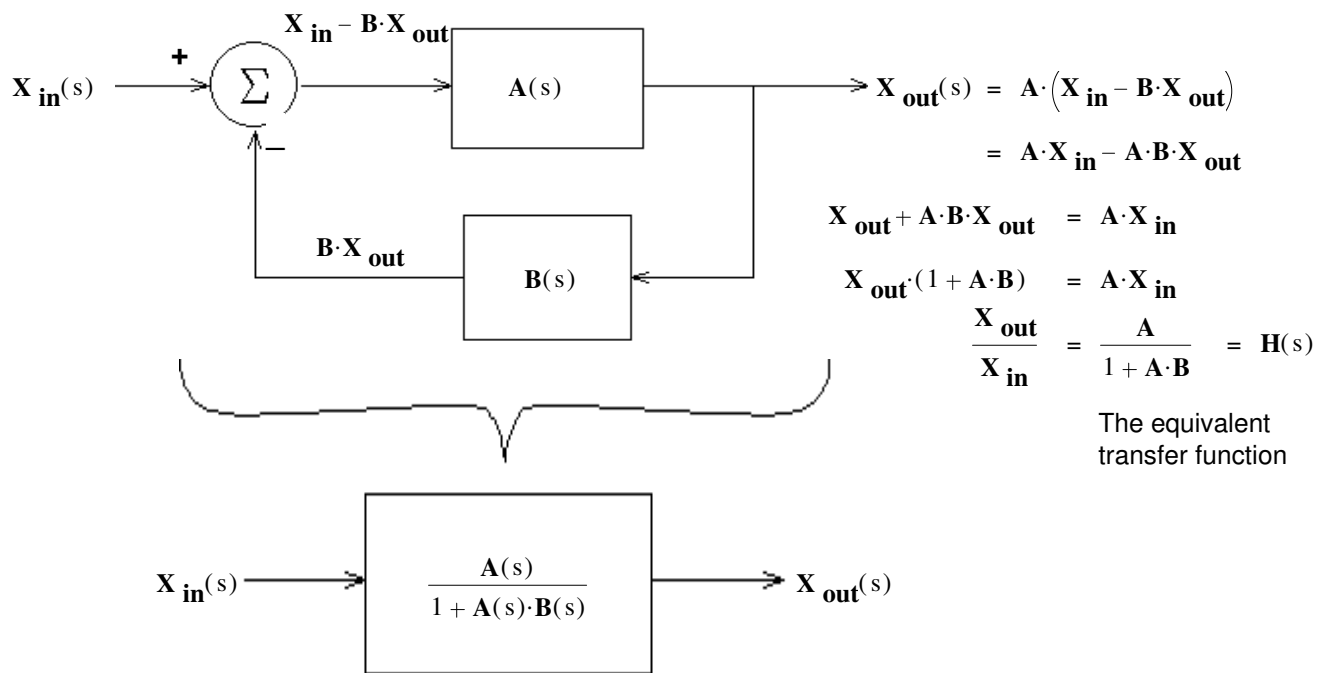

This is called a "closed loop" system, whereas a system without feedback is called "open loop". The term "open loop" is often used to describe a system that is out of control.

The servo used in our lab can be represented by:

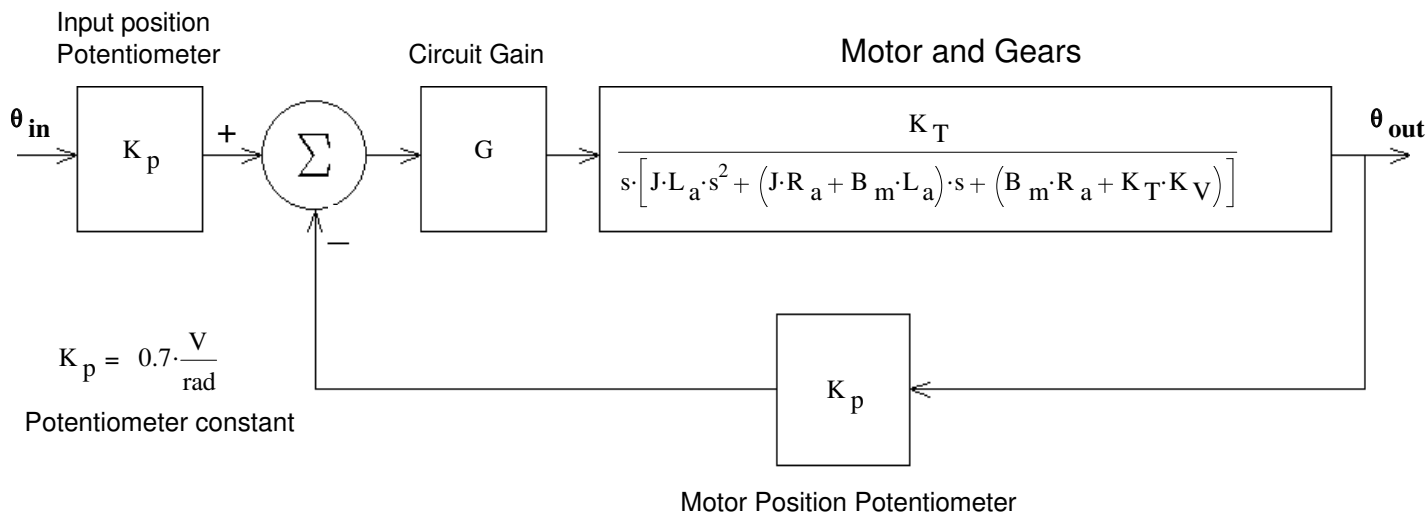

$$H(s) = \frac{\theta_{out}(s)}{\theta_{in}(s)} = \frac{G \cdot K_T \cdot K_p}{s \cdot [J \cdot L_a \cdot s^2 + (J \cdot R_a + B_m \cdot L_a) \cdot s + (B_m \cdot R_a + K_T \cdot K_V)] + K_p \cdot G \cdot K_T}$$

See the appendix to lab 9 for the complete analysis

Note: You already have this in Week09 handouts and/or homework 15-17 handout

1. For the circuit at right:

- Find the characteristic equation of the circuit at right.
- Find the solutions to the characteristic equation.
- Is this circuit over, under, or critically damped?
- The switch has been in the top position for a long time and is switched down at time $t = 0$. Find the final and initial conditions:

$$v_C(\infty), i_L(\infty), v_C(0), i_L(0), \frac{d}{dt}v_C(0) \text{ and } \frac{d}{dt}i_L(0)$$

- Write the full expression for $i_L(t)$, including all the constants that you find.

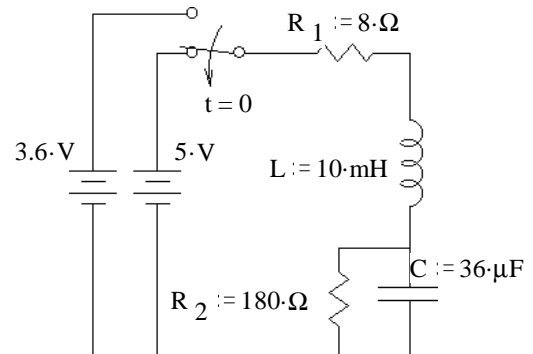

2. a) Find the characteristic equation of the circuit at right.

- Find the solutions to the characteristic equation.
- Is this circuit over, under, or critically damped?
- Find the final conditions: $i_L(\infty)$ and $v_C(\infty)$

- The switch has been open for a long time and is switched down at time $t = 0$. Find the initial conditions:

$$i_L(0), v_C(0) \text{ and } \frac{d}{dt}v_C(0)$$

- Write the full expression for $v_C(t)$, including all the constants.

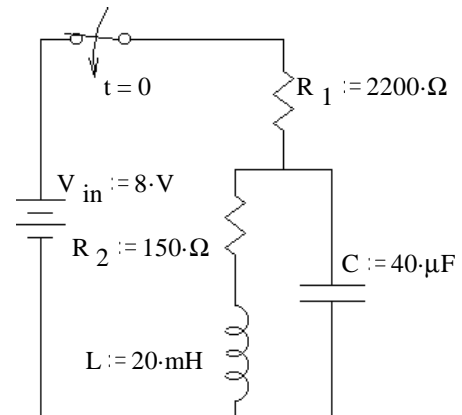

Answers

1. a) $s^2 + \left(\frac{R_1}{L} + \frac{1}{C \cdot R_2}\right) \cdot s + \left(\frac{1}{C \cdot L} + \frac{R_1}{R_2 \cdot C \cdot L}\right) = 0$ b) $s_1 := (-477 + 1635j) \cdot \frac{1}{\text{sec}}$, $s_2 := (-477 - 1635j) \cdot \frac{1}{\text{sec}}$

c) underdamped d) $4.79 \cdot \text{V}$ $26.6 \cdot \text{mA}$ $3.45 \cdot \text{V}$ $19.15 \cdot \text{mA}$ $0 \cdot \frac{\text{V}}{\text{sec}}$ $140 \cdot \frac{\text{A}}{\text{sec}}$

e) $i_L(t) = 26.6 \cdot \text{mA} + e^{\frac{-477.2}{\text{sec}} \cdot t} \cdot \left(-7.45 \cdot \cos\left(\frac{1635}{\text{sec}} \cdot t\right) + 83.45 \cdot \sin\left(\frac{1635}{\text{sec}} \cdot t\right) \right) \cdot \text{mA}$

2a) $0 = s^2 + \left(\frac{R_2}{L} + \frac{1}{R_1 \cdot C}\right) \cdot s + \left(\frac{1}{L \cdot C} + \frac{R_2}{R_1 \cdot L \cdot C}\right)$ b) $s_1 := -182.2 \cdot \frac{1}{\text{sec}}$, $s_2 := -7329 \cdot \frac{1}{\text{sec}}$ c) overdamped

d) $i_L(\infty) = 3.404 \cdot \text{mA}$ $v_C(\infty) = 0.511 \cdot \text{V}$ e) $i_L(0) = 0 \cdot \text{mA}$ $v_C(0) = 0 \cdot \text{V}$ $\frac{d}{dt}v_C(0) = 90.91 \cdot \frac{\text{V}}{\text{sec}}$

f) $v_C(t) = 0.511 \cdot \text{V} - 0.511 \cdot \text{V} \cdot e^{-182.2 \cdot t} + 0.000295 \cdot \text{V} \cdot e^{-7329 \cdot t}$

1. Analysis of the circuit shown yields the characteristic equation below. The switch has been in the top position for a long time and is switched down at time $t = 0$. Find the initial conditions and write the full expression for $i_L(t)$, including all the constants that you find.

$$s^2 + \left(\frac{1}{C \cdot R_2} + \frac{R_1}{L}\right) \cdot s + \left(\frac{R_1}{L \cdot C \cdot R_2} + \frac{1}{L \cdot C}\right) = 0$$

$$\left(\frac{1}{C \cdot R_2} + \frac{R_1}{L}\right) = 1000 \cdot \text{sec}^{-1} \quad \left(\frac{R_1}{L \cdot C \cdot R_2} + \frac{1}{L \cdot C}\right) = 2.222 \cdot 10^6 \cdot \text{sec}^{-2}$$

$$s^2 + 1000 \cdot \frac{1}{\text{sec}} \cdot s + 2.222 \cdot 10^6 \cdot \frac{1}{\text{sec}^2} = 0$$

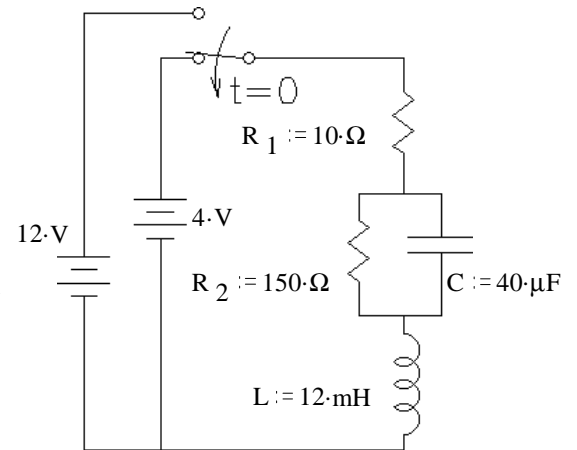

2. What value of R_1 would make the above circuit critically damped?
3. Look at the circuit in HW 17, problem 2. Change R_1 and R_2 to 50Ω and consider the voltage across R_1 to be the output voltage. The transfer function would be:

$$H(s) = \frac{V_{R1}(s)}{V_{in}(s)} = \frac{s^2 + \frac{R_2}{L} \cdot s + \frac{1}{L \cdot C}}{s^2 + \frac{R_1 \cdot R_2 \cdot C + L}{R_1 \cdot L \cdot C} \cdot s + \frac{R_1 + R_2}{R_1 \cdot L \cdot C}} = \frac{s^2 + 2500 \cdot s + 1.25 \cdot 10^6}{s^2 + 3000 \cdot s + 2.5 \cdot 10^6}$$

- a) What are the poles and zeros of this transfer function?
- b) Plot these poles and zeros on the complex plane.
4. A feedback system is shown in the figure. a) What is the transfer function of the whole system, with feedback.

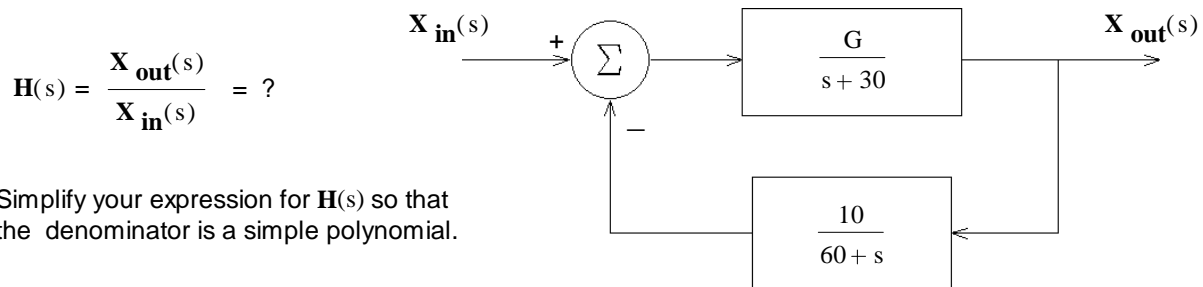

- b) $G := 5$ Find the poles and zeroes of the system.
- c) What type of damping response does this system have?
- d) Find the value of G to make the transfer function critically damped.
- e) If G is double the value found in part d) what will the damping response of the system will be?

ECE 2210 homework # 18 p2

5. a) A feedback system is shown in the figure. What is the transfer function of the whole system, with feedback.

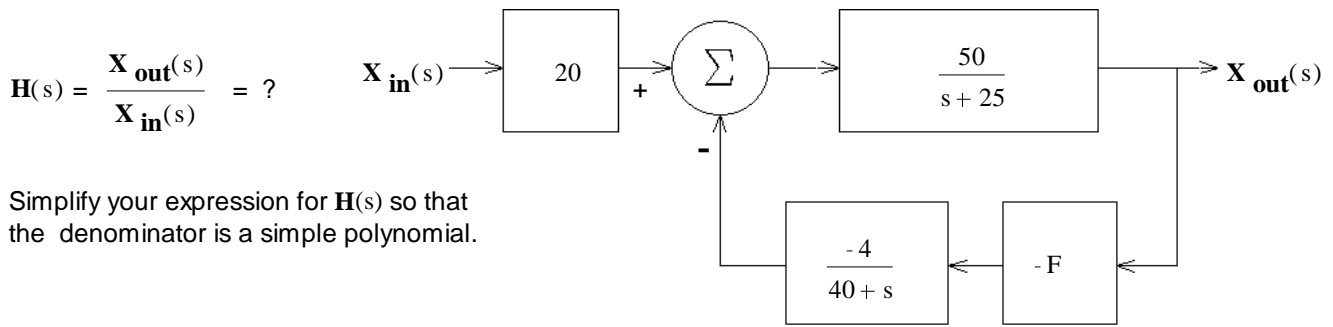

Simplify your expression for $H(s)$ so that the denominator is a simple polynomial.

- b) Find the maximum value of F so that the system does not become underdamped.
- c) Find the transfer function with $F := 0.2$
- d) With $F = 0.2$, at what value of s can the system produce an output even with no input? (That is, what value of s makes $H(s) = \infty$?)
- e) Does the transfer function have a zero? Answer no or find the s value of that zero.

Answers

1 $i_L(0) = 75 \cdot \text{mA}$ $v_C(0) = 11.25 \cdot \text{V}$

$$i_L(t) = 25 \cdot \text{mA} + e^{-\frac{500}{\text{sec}} \cdot t} \cdot \left(50 \cdot \text{mA} \cdot \cos\left(\frac{1404}{\text{sec}} \cdot t\right) - 457 \cdot \text{mA} \cdot \sin\left(\frac{1404}{\text{sec}} \cdot t\right) \right)$$

2. $R_1 = 36.64 \cdot \Omega$

3. a) Zeroes: -691 & -1809 Poles: $-1500 \pm 500 \cdot j$

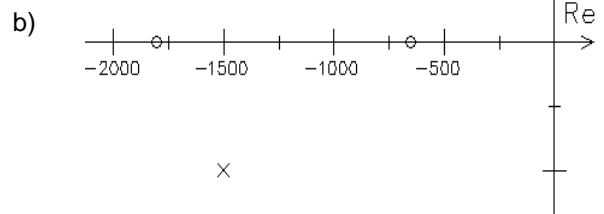

4. a) $\frac{G \cdot (s + 60)}{s^2 + 90 \cdot s + 1800 + G \cdot 10}$

- b) poles: -31.8 & -58.2
- c) overdamped

- zero: -60
- d) 22.5
- e) underdamped

5. a) $1000 \cdot \frac{s + 40}{s^2 + 65 \cdot s + 1000 + 200 \cdot F}$

b) 0.281

c) $1000 \cdot \frac{s + 40}{s^2 + 65 \cdot s + 1040}$

- d) -28.5 or -36.5
- e) -40