

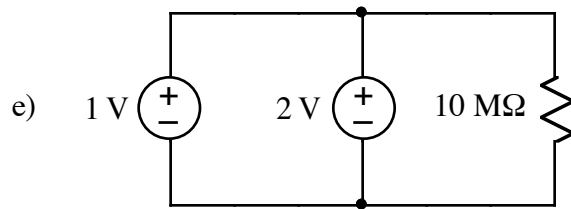

1. Determine whether each of the following circuits is valid or invalid.

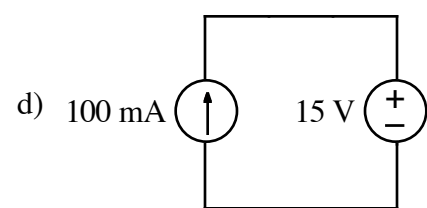

2.

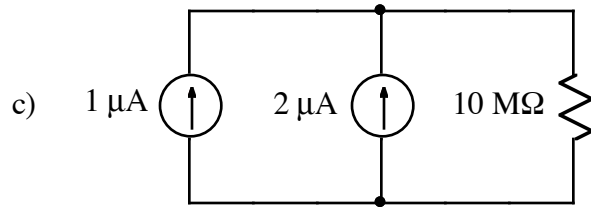
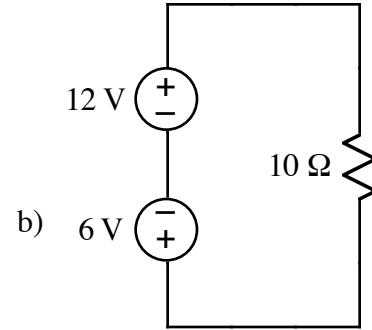
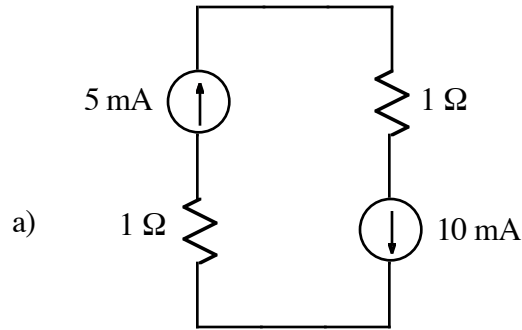
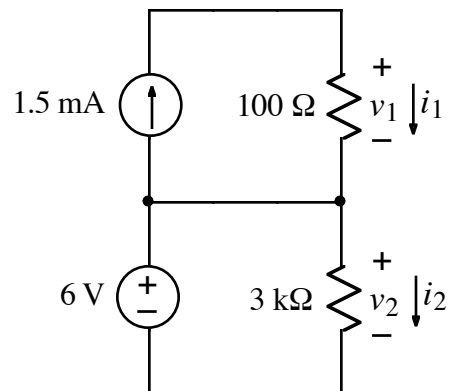

Use Kirchoff's laws to find  $i_1$  and  $v_2$ .

3.

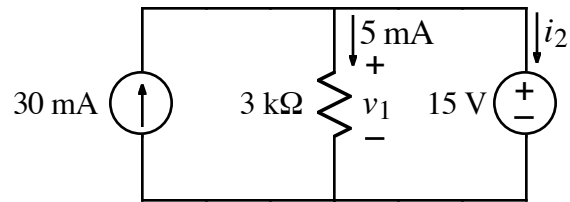

Use Kirchhoff's laws to find the value of  $v_1$  and  $i_2$ .

4.

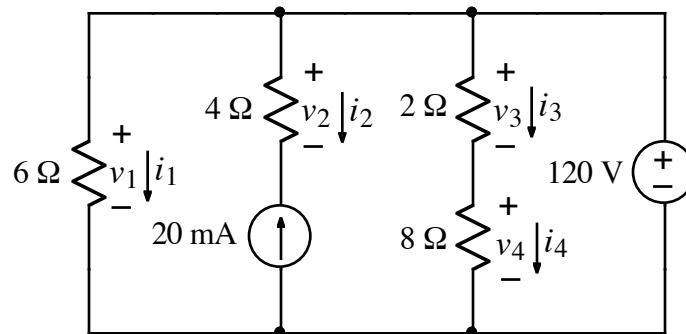

- For the circuit shown above, use Kirchhoff's laws to write equations relating voltages and currents.
- Find the value of  $v_1$  and  $i_2$ .

5.

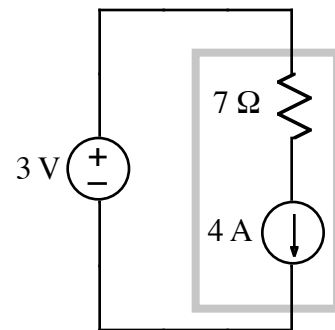

Find the total power dissipated by the components inside the box.