

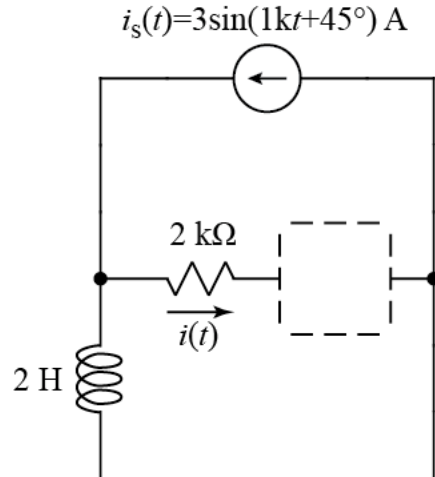

1. Give numerical answers to each of the following questions:

- Rationalize $\frac{5(j20)}{-10 - j20}$. Express your answer in rectangular form.
- Find the polar form of $\left(\frac{5(j20)}{-10 - j20}\right)^*$. (Note: the asterisk means "conjugate".)
- Given $\omega = 2\text{k rad/sec}$, find the following inverse phasor:
 $P^{-1}[j50]$
- Find the magnitude of $\left(\frac{2j^2}{1+j}\right)\left(\frac{e^j\sqrt{j}}{1-j}\right)$.
- Find the imaginary part of $\frac{e^{-j90^\circ}}{1-j}$.

2.



Choose an R , an L , or a C to be placed in the dashed-line box to make

$$i(t) = I_0 \cos(1kt + 45^\circ)$$

where I_0 is a positive, (i.e., nonzero and non-negative), real constant with units of Amps. State the value of the component you choose.

3. Using the value of the component you chose for Problem 2, calculate the resulting value of I_0 .

4.

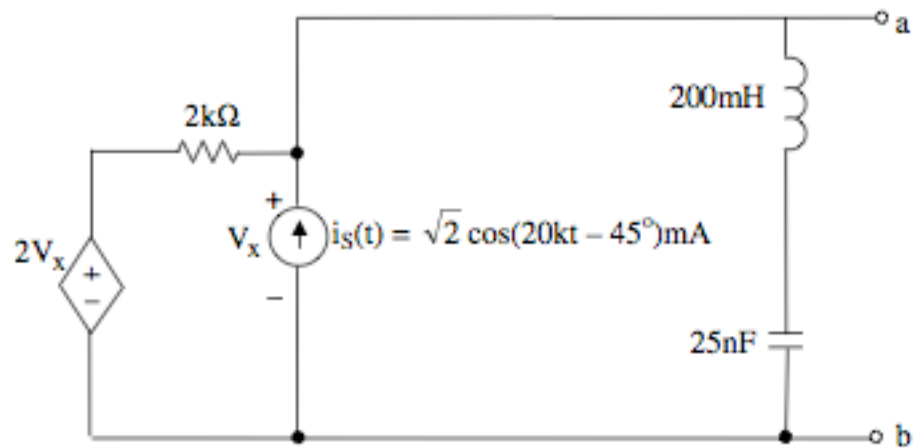

Draw a frequency-domain equivalent of the above circuit. Show a numerical phasor value for $i_s(t)$, and show numerical impedance values for R , L , and C . Label the dependent source appropriately.

5.

Find the Thevenin equivalent (in the frequency domain) for the above circuit. Give the numerical phasor value for V_{Th} and the numerical value for the impedance value of z_{Th} .