

Ex: Draw the frequency-domain circuit diagram (with numerical values for impedances and phasors [except the dependent source which will be labeled $6\mathbf{I}_x$]) for the following circuit:

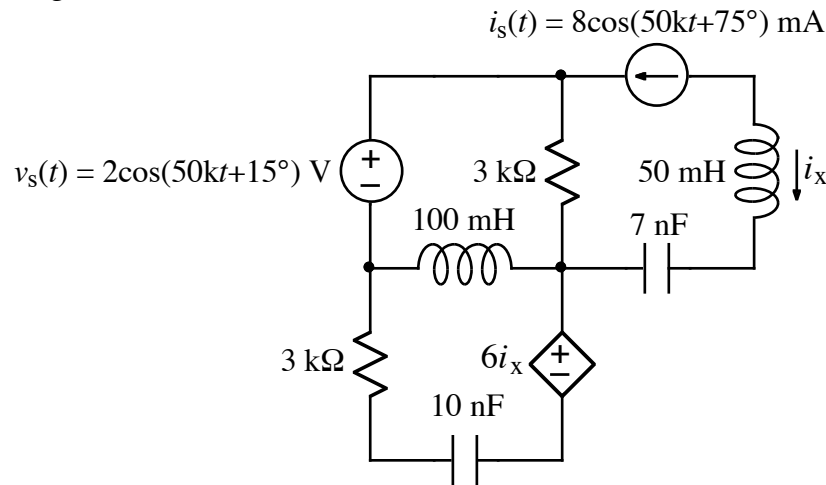

SOL'N: In the frequency-domain, we use phasors for voltages and currents, and impedances for resistors, capacitors, and inductors.

The phasor transform is captured by the following equation:

$$P[A\cos(\omega t + \phi)] = Ae^{j\phi} \equiv A\angle\phi$$

We apply this equation to v_s and i_s using the same units in the frequency-domain as in the time-domain. The circuit diagram, below, shows the values.

The impedances are calculated with the following formulas:

$$z_R = R \qquad z_L = j\omega L \qquad z_C = \frac{1}{j\omega C} = \frac{-j}{\omega C}$$

The values are shown on the circuit diagram below. We may save some effort by noting that doubling the value of L increases the impedance by a factor of two, whereas doubling the value of C decreases the impedance by a factor of two.

