

Interconnects and Packaging of Millimeter Wave Circuits



**Wolfgang Menzel, Distinguished
Microwave Lecturer**

**Wolfgang Menzel
Microwave Techniques
University of Ulm
PO Box D-89069
Ulm, Germany**

Abstract—This contribution presents a number of aspects relevant for interconnects and packaging of monolithic integrated circuits, possibly combined with hybrid or even waveguide circuits in the millimeter-wave range. Examples of different interconnects and two realized front-ends are demonstrated.

I. Introduction

In recent years, great efforts have been undertaken to develop mm-wave monolithic integrated circuits (MIMICs) which now are being introduced into radar [1], [8] and communication equipment [2]. Especially for low cost civil systems, however, there is still a lack of suitable and affordable techniques for interconnects and packaging of MIMICs, possibly together with hybrid integrated circuits or even waveguide. Packaging of micro- and mm-wave MICs, MIMICs, components or subsystems has to provide protection against mechanical stress, environmental loads like moisture

and chemicals, and, in some cases, against electromagnetic interferences (EMI). In addition, the complete assembly must operate in a wide temperature range, and it must allow the removal of heat generated in its interior [3] - [7]. Equally, packaging includes interconnects between different circuits (possibly between different types of transmission lines, too), feed through elements into and out of the package, choice of materials, or front-end architecture. With increasing mass applications like phased arrays [4], [8] or traffic applications [1], packages have to be fabricated and assembled easily and quickly based on reliable processes at reasonable cost. All these problems are increasingly relevant for applications at mm-wave frequencies. Therefore, this contribution will address topics like front-end architecture for mm-wave circuits based on different transmission line media, package materials, circuit interconnects, feed-through elements, and two approaches for front-end packaging.

II. Packaging and front-end architecture

While at lower frequencies, single devices or single MMICs are placed into a package, this mostly is not effective at millimeter wave frequencies. Even a single MIMIC is no longer small compared to wavelengths resulting in package resonance problems, and the cumulating effects of the interconnects from the MIMIC to the package feed-through, out of the package and from one packaged component to the other will add to high insertion and return losses. Therefore, carefully designed assemblies of MIMICs, passive components, radiating structures and other elements have to be combined to subsystems or "supercomponents" and will be placed together on a metal or dielectric carrier, shielded by a single package with special precautions against package resonances. Two examples for this will be presented in section VI. The combination of components will be determined by good functionality, short interconnects for

low noise figure or low loss in transmitter power paths, low number of package feed-through elements, limitation of interferences between single components, limitation of gain within one package (feedback prevention), sufficient removal of heat generated by active devices, separation of power and low noise elements etc. Typical topics to be considered are package materials, carrier plate material, or choice of transmission line types.

III. Package materials

Metal as material for at least part of a package shows optimal properties concerning thermal conductivity, electromagnetic shielding, mechanical and thermal stability. For thermal expansion, best match to semiconductor and ceramic materials can be achieved with molybdenum, tungsten, or special composites like kovar. These, however, exhibit a medium thermal conductivity only and are difficult to machine and therefore expensive. Copper tungsten or copper molybdenum provide an improved thermal conductivity and a thermal expansion coefficient matched to semiconductor materials combined with high stability. Standard metals with good electrical and thermal conductivity like aluminium or brass (mostly plated with a less corrosive layer), are cheaper for these applications, but special precautions have to be taken due to their higher thermal expansion. Fabrication of metal package parts may be done using standard machining procedures or injection casting; new techniques like metal powder sintering and metal injection moulding may pave the way for reduced production cost.

Ceramic materials are applied both as parts of the package as well as for substrates carrying RF transmission lines. To this end, and to provide electromagnetic shielding, these materials (partly) have to be metallized. Beryllia (poisonous), aluminium nitride, or aluminium silicon carbide show best thermal conductivity and are therefore applied in high power appli-

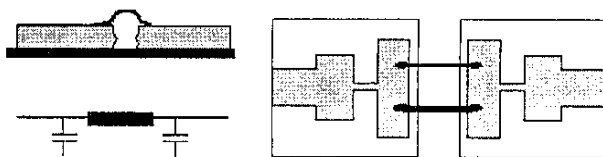

Fig. 1: Microstrip - microstrip bonding, equivalent circuit and compensated bonding interconnect.

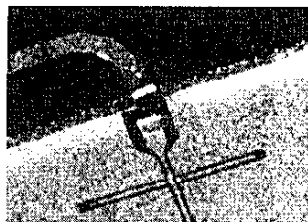

Fig. 2: Transition from a microstrip chip to a coplanar line on a carrier substrate (courtesy of Daimler-Benz Research Institute, Ulm).

cations, while alumina is well known from standard microwave applications. These materials show a low thermal expansion sufficiently matched to semiconductors. Ceramic parts typically are fabricated from fine powder, pressed to the required form and sintered at high temperatures. The sintering leads to a considerable shrinking of the dimensions which has to be taken into account during the design.

In some applications, even quartz [12] with its relatively low dielectric constant or silicon which can be formed with micromachining techniques [13] are used.

Plastic materials are cheapest in material and production cost; pure plastic provides,

however, a number of challenges concerning mechanical and thermal stability and thermal expansion. Even as substrate material, PTFE is enforced by fillings like glass fiber or ceramic powder. At lower frequencies, leadframes are used as stabilizing elements

[6].

As a relative stable material for packages, polymers with special fillings of ceramic powder, glass or carbon fibers or even metal powder have been investigated [5]. These composite materials are engineered for high stability and low thermal expansion, they can withstand temperatures up to 200° C, and they may be easily fabricated employing powder or metal injection techniques. Metal inserts are used to remove heat from active areas. Liquid crystal polymers with their anisotropic behaviour may be of interest for a low thermal expansion in one plane [5]. Special care has to be taken using plastic materials with respect to hermeticity; in most cases, a metallisation will be used to keep penetration of vapour low enough; this improves, at the same time, the electromagnetic shielding of the package.

IV. Circuit interconnects

At mm-wave frequencies, interconnects between different MIMIC chips or to an additional substrate with either hybrid circuits or interconnect lines behave more and more as strong discontinuities. Dye bonding is as well as the

interconnects themselves require tight tolerances, but in spite of this, the respective production processes should be easy and low cost. Therefore, the choice of the best interconnect technique, a good model for the microwave (and possibly thermal) behaviour, and a tolerance oriented optimisation is necessary. Equivalent circuit models as well as full wave calculations of different types of interconnects therefore are investigated.

A - Microstrip - Microstrip Interconnects

A great part of the present MMICs are based on microstrip. Therefore, an interconnect between two chips or between one chip and a hybrid circuit placed side by side is of great importance. Due to tolerances in chip size, nonregular edges of the chips, and thermal expansion, some gap must remain between the two substrates, and the bonding structure must include some kind of loop. This, however, leads to a pronounced low pass behaviour of the interconnect (Fig. 1) resulting in increased difficulties with increasing frequency. As bonding elements, one or two wires (the edges of the lines), bond tapes, or special tapes integrated on thin dielectric carriers (TAB: tape automated bonding, [7]) are employed. At mm-wave frequencies, however, some compensation of the low pass performance of such transitions is necessary. One proposal is based on a theoretical model of bond wire interconnects [14] and a flexible compensation network. Depending on the gap between two circuits, the distance of two bonds is modified such that a good transmission performance is maintained [5], Fig. 1. The

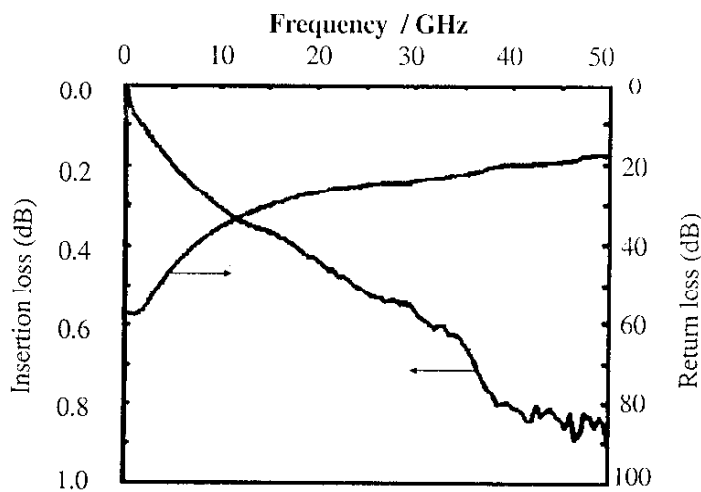

Fig. 3: Return and transmission loss of a double transition from a microstrip chip to a coplanar line on a carrier substrate (courtesy of Daimler-Benz Research Institute, Ulm).

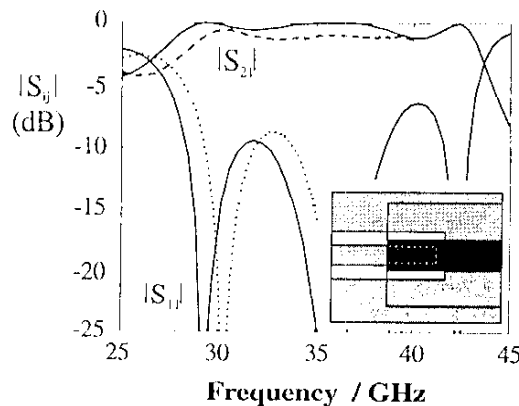

Fig. 4: Back to back transition from coplanar line to microstrip using electromagnetic field coupling.

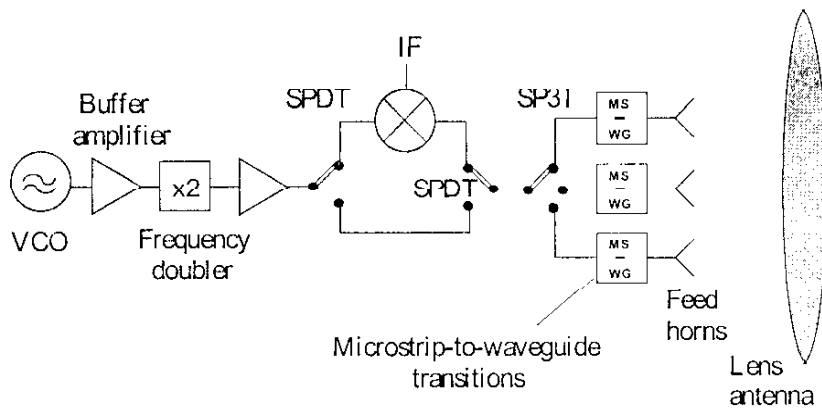

Fig. 5: Block diagram of automotive radar front-end [1].

distance between the chips is monitored by a camera, and by a suitable algorithm, bond wire positions and loop height are adjusted and controlled automatically. Up to 100 GHz, a return loss of better than 20 dB is predicted theoretically including reasonable ranges of gap widths as well as dye and loop bonding tolerances.

B - Coplanar - Coplanar Waveguide Interconnects

Coplanar circuits are gaining increasing, great efforts are done developing effective interconnect techniques for this type of transmission line, too. Placing two coplanar circuits side by side ends up in even more severe problems compared to microstrip, as the ground plane has to be bonded together, too [15]. Therefore, flip-chip techniques have been introduced consisting of bumps fabricated (with galvanic processes) on top of the circuit metallisation. The MMIC - or even a single device like a FET - then is placed top down and bonded to an equivalent coplanar transmission line structure on a carrier substrate. The same technique can be used to remove the heat of active elements via bumps placed directly at the FET source region [8]. The height of the bumps should be about three times the coplanar slot width (or equal to the ground-to-ground distance) to prevent interactions with the carrier substrate; typical values are 30...75 μm . At mm-wave frequencies, some concern has to be made about the inductance of the bumps [16]. In any case, flip-chip mounting provides an effective and economical interconnect technique in the mm-wave range [2], [15], [17].

C - Mixed interconnects

For some applications, microstrip MMICs may favourably be placed on top of a carrier substrate using coplanar interconnect lines. The ground planes of both circuits then are in the same plane, and as typically, the microstrip substrate height is relatively small, a galvanic interconnect from the microstrip line to the center coplanar line is feasible. A photograph and experimental results are shown in Figs. 2 and 3.

A more elegant solution uses electromagnetic field coupling [11], [18]. At mm-wave frequencies, quarter wave structure on GaAs measure only a few tenths of a mm being compatible with the size of MMICs. The microstrip circuit must have a gap in the ground metallisation in the coupling area; this, however, should not be any problem as some back side structuring is done anyway to enable dye separation. As an example of this technique, the results of a transition from a coplanar line on a carrier substrate to a microstrip line on a GaAs substrate (and back) with electromagnetic coupling (including some small matching structure on the carrier substrate) is presented in Fig. 4.

V. Package feed-through elements

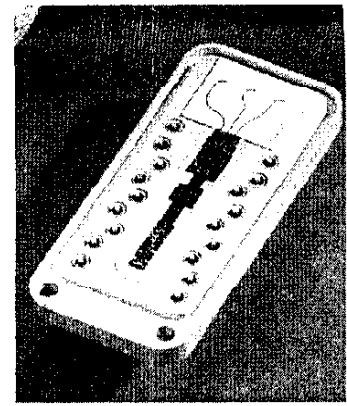

Fig.6: Photograph of automotive radar front-end [1] (courtesy of Daimler-Benz Aerospace, Ulm).

A package feed-through structure has to provide an electrical interconnect into or out of the package maintaining a good seal and mechanical as well as thermal stability. With increasing frequencies, the width of a package wall, especially in conjunction with a material of high dielectric constant like ceramics, is no longer small compared to wavelength. Regarding possible discontinuities of the interfaces at the package wall edges, strong reflections may occur, and some compensation has to be included. For measurement purposes, coaxial cables and connector systems have been pushed into the mm-wave frequency region. Consequently, efforts are made to extend these systems to packaging techniques. The coaxial systems, however, require very stringent tolerances (a few μm only), and above 40 GHz, they pose severe problems with the transition to planar circuits within the package. Using planar lines on a carrier substrate serving, at the

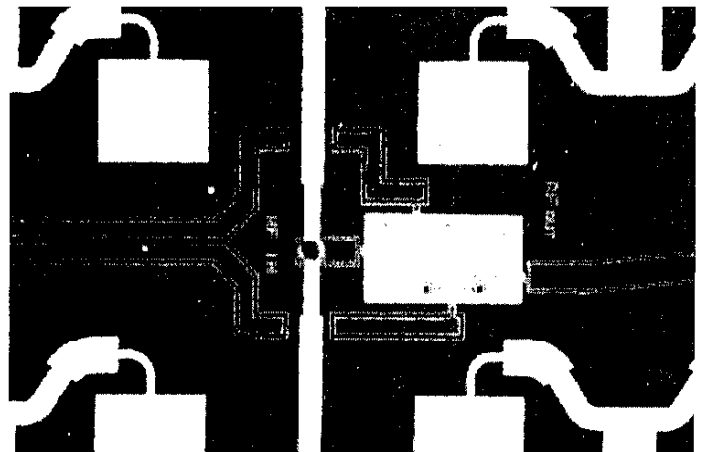

Fig. 7: Photograph of some details of a communication front-end ([2], courtesy of SEL-Alcatel, Stuttgart).

same time, as package carrier, the lines could easily be extended out of the package. Suitable compensating and matching structures have to be included to compensate the involved discontinuities [9], [10]. In addition, attention has to be paid to possible resonances of the feed-through structure [9]. For a compact integration of microwave and mm-wave front-ends, multilayer structures are used as carrier substrates which can support a complex interconnect network [6], [19]; a possible material for such substrates is low temperature cofired ceramic (LTCC), [20].

VI. System examples

To demonstrate some packaging technologies, two front-ends realized within research projects in Germany will be described in this section. The first one is the mm-wave part of a 76.5 GHz automotive radar [1]. Its general block diagram is shown in Fig. 5. In this pulse radar, the oscillator based on a 38 GHz voltage controlled oscillator (VCO) together with a frequency doubler serve both as transmitter and local oscillator (LO). To enable some imaging of the street in front of the car, three waveguide feed horns for three different antenna beam angles alternatively illuminate a dielectric lens. All circuits are realized as MIMICs, placed side by side on a carrier plate made from a plastic compound. The mm-wave interconnects are done by compensated bonds [5], the transitions from microstrip to waveguide according [11]. The heat generated by the active elements is removed by a metal insert in the carrier plate. A photograph of this arrangement is shown in Fig. 6.

The second example is a receiver for the 50 to 60 GHz frequency range. It includes a number of MIMICs and a planar antenna array on a substrate serving, at the same time, as integral part of the package [2]. The critical part of this front-end is the transition from the planar antenna to the first low noise amplifier (LNA). Therefore, the LNA is placed directly on the back side of the antenna substrate close to the antenna feed point and connected by flip-chip bonding.

To this end, a galvanic interconnect through the antenna substrate and some sections of coplanar line on the back side of the substrate are included. The interconnects to and between the remaining MIMICs are less critical and are done by conventional wire bonding. A view on the antenna substrate is given in Fig. 7.

Acknowledgment

Part of the work described in this contribution was funded by the German Ministry of Research under different contracts. Thanks are due, too, to Daimler-Benz Aerospace and the Daimler-Benz Research Institute, Ulm, and SEL-Alcatel, Stuttgart, for providing photographs and results of their work.

References

- [1] Daembkes, H., Luy, J. F.: Millimeterwave components and systems for automotive applications. *Microwave Engineering Europe* (Dec.-Jan. 96), 43 - 48.
- [2] Baumann, G. et al.: 51 GHz Frontend with Flip Chip and Wire Bond Interconnections from GaAs MMICs to a Planar Patch Antenna. *IEEE Intern. Microw. Symp. MTT-S*, 1995, Orlando, USA, 1639 - 1641.
- [3] Berson, B.: Strategies for microwave and millimeter wave packaging today. *IEPS, Proc. Of the tech. Program, 9th Annual Intern. Electronics Packaging Conf.*, San Diego, USA, 1989, Vol. 1, 697 - 720.
- [4] Bierman, H.: Designers strive for low cost packages. *Microw. J.*, Sept. 1992, 100 - 106.
- [5] Boheim, M., Goebel, U.: Low Cost Packages for Micro- and Millimeterwave Circuits. *24th European Microw. Conf.*, 1994, Cannes, France, 122 - 132.
- [6] Nagy, C. et al.: Advanced Manufacturing and Packaging Technologies for Military and Commercial Markets. *Microw. J.*, Aug. 1995, 22 - 36.
- [7] Reichel, H.: Packaging aspects of single and multichip modules. *EuPac '94, 1st European Conference on Electronic Packaging Technology & 7th Intern. Conference on Interconnection Technology in Electronics*, 1994, 6 - 9.
- [8] L. M. Felton: High yield GaAs Flip-Chip MMICs Lead to Low Cost T/R Modules. *IEEE Intern. Microw. Symp. MTT-S*, 1994, San Diego, USA, 1707 - 1710.
- [9] Rittweger, M. et al.: 3D FDTD Analysis Applied to the Investigation of the Resonant Behavior of Ceramic Feedthrus. *IEEE Intern. Microw. Symp. MTT-S*, 1994, San Diego, USA, 1719 - 1722.
- [10] Christ, A.: S-parameter calculations using three-dimensional finite differences for microwave chip interconnects (in German). PhD Thesis, Tech. Univ. Darmstadt, Germany, 1988.
- [11] Grabherr, W.; Huder, B.; Menzel, W.: Microstrip to waveguide transition compatible with mm-wave integrated circuits. *IEEE Trans. on MTT*, September 1994, 1842-1843.
- [12] Shih, Y. C. et al.: A High Performance Quartz Package for Millimeter-Wave Applications. *IEEE Intern. Microw. Symp. MTT-S*, 1991, Boston, USA, 1063 - 1066.
- [13] Robertson, S. V. et al.: Micromachined Self-Packaged W-Band Bandpass Filter. *IEEE Intern. Microw. Symp. MTT-S*, 1995, Orlando, USA, 1543 - 1546.
- [14] Alimenti, F. et al.: Quasi Static Analysis of Microstrip Bondwire Interconnects. *IEEE Intern. Microw. Symp. MTT-S*, 1995, Orlando, USA, 679 - 682.
- [15] Krems, Th., Haydl, W., Massler, H Ruediger, J.: Millimeter-Wave Performance Chip Interconnections Using Wire Bonding and Flip Chip. *IEEE Intern. Microw. Symposium MTT-S*, 1996, San Francisco, 247 - 250.
- [16] Jin, H. et al.: Rigorous Field Theory Analysis of Flip-Chip Interconnections in MMICs Using the FDTLM Method. *IEEE Intern. Microw. Symp. MTT-S*, 1994, San Diego, USA, 1711 - 1714.
- [17] Sakai, H. et al.: A novel millimeter-wave IC on Si substrate using flip-chip bonding technology. *IEEE Intern. Microw. Symp. MTT-S*, 1994, San Diego, 1763 - 1766.
- [18] Strauß, G., Menzel, W.: Millimeter-Wave Monolithic Integrated Circuit Interconnects Using Electromagnetic Field Coupling. *IEEE Trans. on CPMT, Pt. B*, Vol. 19, May 1996, 278 - 282.
- [19] Session on High Density Microwave Packaging Program. *Proc. of IEEE Intern. Microw. Symp. MTT-S*, 1995, Orlando, USA, 169 - 184.
- [20] Brown, R. L., Polinski, P. W., Shaikh, A. S.: Manufacturing of microwave modules using a low-temperature cofired ceramics. *IEEE Intern. Microw. Symp. MTT-S*, 1994, San Diego, 1727 - 1730.

