

DETECTION OF INTERMITTENT FAULTS IN AIRCRAFT ELECTRICAL WIRE BY UTILIZING POWER LINE COMMUNICATION

Charles Kim and Nicholas Johnson
Department of Electrical and Computer Engineering
Howard University

Abstract

Intermittent electrical faults and insulation failures in aging aircraft are causing many problems including electrical fires or even worse, fuel tank explosions, ignited by arc and sparks generated from faulty contacts. Arcing faults develop by long process of electric wire degradation, cuts, burns, or loose contacts, and they are not easily detected. The long operational lifespan of aircraft makes them prime examples where intermittent faults occur due to aging degradation. The current method of preventive maintenance of electrical wire system in aircraft is grounding and observation, which causes loss of flight time of aircraft and thus loss of revenue. Moreover, testing electrical wires in hard-to-see/reach location is tough and challenging.

The objective of the study is to provide a novel approach of monitoring aircraft electrical wire system and locating suspected areas of failures and loose contacts. The new approach is very different from conventional diagnostic methods of arcing fault detection. Unlike the conventional approach of monitoring intermittent, high-frequency component, signal generated by arc/spark in faulty wire or loose contact, via analog signal acquisition, filtering, and signal processing, our approach injects modulated signal at a location to the electrical wire system and diagnose the health status of the wire by measuring the error rate of the modulated signal at another location of the system. It is believed that the intermittent faults and failures, and the transients generated by such activities would disrupt the transmission of the modulated signal.

We found that the simulated intermittent faults of switching action indeed distorted the messages transmitted via the PLC. The longer duration of the noise generated on the electrical wire was credited for the visible increase in the number of errors. However, transients with short duration did not distort the message sufficiently to cause a visible effect on the error rate. In addition, we observed that when intermittent faults were generated via a rubbing action there was a large increase in the error rates. We also observed a direct relationship between the amount of messages with errors and the frequency of the intermittent faults. It was seen that the duration of this noise was a lot greater than that being generated by the switching action, in the order of milliseconds.

Further investigation of the effects of intermittent faults on PLC data transmission is required. Future work will include the reduction of inherent errors in the system in order to increase result accuracy. Also, the use of a different PLC chip may allow us to detect noise in the MHz range.

I. Introduction

An intermittent fault is a physical event that manifests itself intermittently in an unpredictable manner [1]. Therefore, when a system is subject to intermittent fault, the system produces erroneous results or could be subject to a major failure and then it will go back to produce correct results or returns to normal status.

The long operational lifespan of aircraft make them prime examples where intermittent faults occur due to aging degradation. Intermittent electrical faults and insulation failures in aging aircraft are causing many problems including electrical fires or even worse, fuel tank explosions, ignited by arc and sparks generated from faulty contacts. Arcing faults develop by long process of electric wire degradation, cuts, burns, or loose contacts, and they are not easily detected.

In older avionics systems, 50% of all pilot-reported operational discrepancies go unrepaired and these undetected intermittent defects are currently being labeled and disguised as "Can Not Duplicate, No Fault Found, False Removal, No Evidence of Failure, No Problem Found, Cannot Verify, Retest OK", and other repair diagnostic descriptions, [2]. The intermittent faults are the most frustrating, elusive, and expensive faults to locate. Some examples of intermittent faults are: a wire rubs against a neighboring wire and creates a small arc; an over-tightened clamp rubs through the insulation and shorts the wire; a pin is backing out of the connector, wire is breaking at the back side of the connector, or corrosion is creating intermittent non-contact with the pins; radial cracks on wires have intermittent faults caused by water dripping on them [3]. Since the intermittent faults occur for a short period of time, it is important to locate the intermittent fault when it is active.

With the cause of the root of the intermittent problem still overlooked by the misnamed descriptions and fragmented solutions, the ability to effectively detect intermittent faults is critical. The current method of preventive maintenance of electrical wire system in aircraft is grounding and observation, which causes loss of flight time of aircraft and thus loss of revenue. Moreover, testing electrical wires in hard-to-see/reach location is tough and challenging. One method of solving the electrical wire fault and fire problem is to develop inflammation-resistance insulation material for electrical wire system. However, any electrical wire in service is aging toward failure. Furthermore, the amount of wiring in transport category aircraft has grown steadily over time, with no plateau in site [4]. The fact that large transport category aircraft now flying contain 200-300 miles of wiring only demonstrates the need for a reliable way to detect intermittent faults that does not result in costly aircraft down-time.

Much research has been done on the subject of wiring fault detection. Some of the more publicized techniques are: time or frequency domain reflectometry, standing wave reflectometry, impedance spectroscopy, high voltage inert gas, resistance measurements, and capacitance measurements. However at the present time, these test methods cannot distinguish intermittent faults without the use of high-voltage. A newer technique being investigated using spread spectrum time domain reflectometry has had some success in detecting faults on controlled impedance coax carrying high-speed digital data [5].

The goal of this paper to determine the feasibility of using power line communication (PLC) to detect intermittent faults in an electrical wire with the hope of applying the technique to aging systems. PLC is a method of transmitting data through existing electrical cables alongside electrical current and promises to be an enabling home network technology due to the ability to transmit data over the existing power lines in homes [6]. Although, most of the research being done using PLC involves the use of PLC in broadband networking and remote monitoring, PLC has also found some limited applications in DC systems such as in the development of a smart motor that combines both the power and control lines into a single wire [7]. However, the PLC system got caught some researchers as a detection tool for power line faults. Taylor and Faulkner proposed direct-sequence spread-spectrum modulation on power line carrier for this application, and outlined optimal signal processing techniques and frequency domain correlation techniques for the on-line test in a 225 km 330kV line [8]. The use of spread spectrum was reported from the research result of Furse and Smith on detecting avionic wire problem [5].

The scheme devised in the paper for intermittent fault detection is to use the communication reliability, or message error, of the PLC system as an indicator of the transmission medium, which is electrical wire, status: clean or noisy. In this paper we investigate the use of PLC in a DC system to detect faults by

monitoring at a receiving station the error rates of bytes and bits of the messages sent over electrical wire when intermittent faults were staged and compare them with a baseline, no fault case.

II. PLC System and Intermittent Fault Detection Approach

1. PLC Method and Definition of Transmission Errors

For the PLC system, we utilized an off-the-shelf PLC chip which uses FSK to transmit data over the power line and is controlled via a microcontroller. The in-house PLC system built by the authors consists of a PLC modem and a microcontroller. The STMicroelectronics ST7537HS1 home automation modem is a half duplex, asynchronous 2400bps FSK modem and was used to establish the PLC. A Parallax Basic Stamp 2 microcontroller was used to control the PLC chip and an external line driver and transformer were used to interface the ST7337HS1 with the power line. Two stations were set up: a transmitting station (Tx) that transmitted message over the wires and a receiving station (Rx) that received the message and compared it with the expected data, as depicted in figure 1.

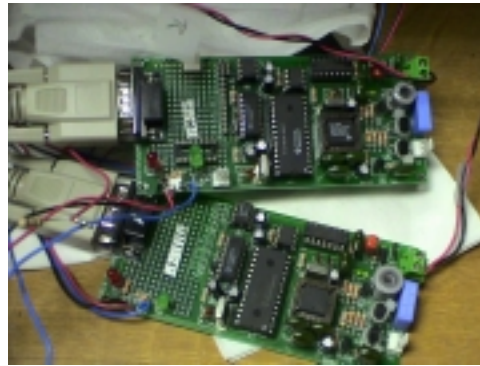

Figure 1. A transmitter (Tx) and a receiver (Rx) set for PLC scheme.

The transmitted message consisted of a total of 24 bytes: 1 preamble byte which alerted the receiver of an incoming message, 2 sync bytes which indicated to the receiver that a valid message followed, 1 byte for the transmission number, 1 byte for the station address of the sender, 1 byte for the station address of the intended recipient, and 18 data bytes. When the receiving station received the message, it compared the received data with what was expected and calculated the number of bytes and bits that were incorrect. The transmission number along with the number of incorrect bytes and bits were then displayed onscreen. This data was saved to a text file and imported into Microsoft Excel for analysis. Initial trials were run with the two stations connected via 22 AWG solid wire of length 2'3" as shown in figure 2. This allowed us to observe the communication system without the presence of intermittent faults.

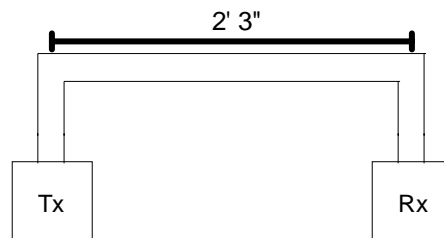

Figure 2. A schematic of the PLC transmitting (Tx) and receiving (Rx) stations used to observe the communication system.

It was believed that an intermittent fault along the line would affect the number of errors that occurred during transmission. Therefore, the first thing we had to consider in our analysis was the message error rate (MER), which is the percentage of messages that contained errors out of the total number of received messages:

$$\text{MER} = \frac{\text{\# of received messages with errors}}{\text{\# of received messages}} \times 100$$

We also observed that not all the messages that were transmitted were received by the receiving station. Therefore, we also considered the percentage of messages that were not received out of the total number of sent messages and called this the lost message rate (LMR):

$$\text{LMR} = \frac{\text{\# of messages sent} - \text{\# of messages received}}{\text{\# of messages sent}} \times 100.$$

After a number of initial trials we found that there existed a high MER without the simulation of intermittent faults. Observation with an oscilloscope revealed that these errors were being generated by the PLC circuit itself and were inherent to our experimental setup. These “inherent errors” were believed to also account for the high LMR since if an error occurs early in the message, such that it distorts the 2 sync bytes or the station address of the intended recipient, the message is ignored by the receiving station. Therefore, we also considered the total error rate (TER), which is the percentage of errors plus lost messages out of the total number of sent messages:

$$\text{TER} = \frac{\text{\# of messages with errors} + \text{\# of messages lost}}{\text{\# of messages sent}} \times 100.$$

2. Experimental Setups for PLC Messaging

The circuit was set up in two configurations: a parallel configuration (figure 3) and a series configuration (figure 4). Again, 22 AWG solid wires were used with wire lengths as shown. The connection points were made by twisting the wires tightly together and soldering them. This was done in order to ensure secure connections and reduce the possibility of any unwanted intermittent faults in our setup. We staged intermittent faults either through the switching action of the switch or by rubbing two wires together directly.

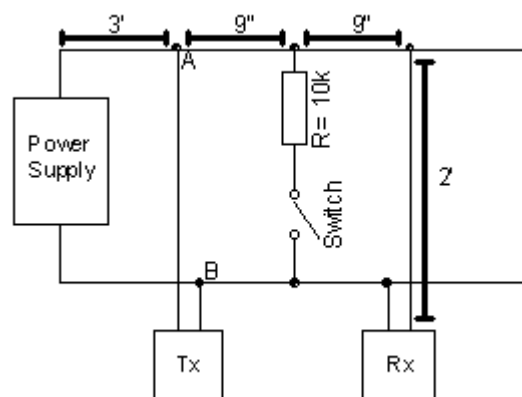

Figure 3. The basic setup for testing the effect of staged intermittent faults in parallel to the power supply on the messages transmitted using PLC.

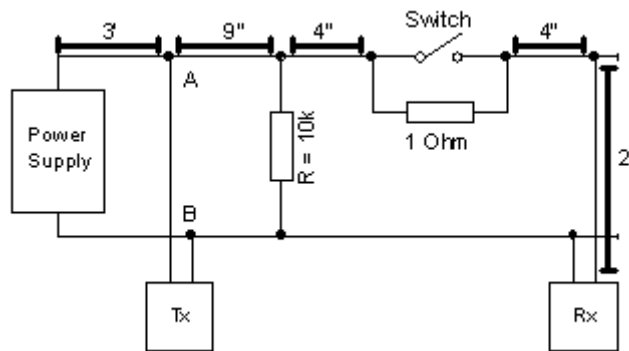

Figure 4. The basic setup for testing the effect of staged intermittent faults in series to the power supply on the messages transmitted using PLC.

In most of the experiments one test run consisted of 1000 message transmissions with a pause of 150ms between transmissions. Figure 5 shows the message as seen in an oscilloscope and shows the occurrence of an inherent error in the second message transmission. The 150ms pause between transmissions was necessary in order give the receiving station adequate time to calculate the number of byte and bit errors in each message, display the data on screen, and prepare itself to receive the next message. A number of tests were also run with a 300ms pause between transmissions. This affected the error rates slightly but not enough to affect our conclusions.



Figure 5. The output from the oscilloscope showing the PLC message as it is being transmitted along the DC power line. The oscilloscope is coupled to the AC signal so that the DC offset is not shown. An inherent error has also occurred in the message transmission.

After initial trials with the two configurations, we observed that, from the initial MER analysis, there existed another type of error other than the inherent errors. We believed that these errors were generated by noise in the circuit and were called “noise errors”. A way of categorizing and separating the inherent and noise errors had to be found since it was believed that an intermittent fault would most likely affect the number of noise errors and not affect the inherent errors. Further observation revealed that inherent errors generally caused a large number of incorrect bytes within a message while a small number of

incorrect bytes were probably attributed to noise. As such, noise errors were defined as those errors that caused a 1 byte change in the message while only affecting 1 or 2 bits. The separation of noise errors from the inherent errors allowed us to find the noise error rate (NER). The NER is the percentage of messages with noise errors out of the total number of messages received:

$$\text{NER} = \frac{\text{\# of received messages with noise errors}}{\text{\# of received messages}} \times 100.$$

A number of experiments were run on both the parallel and series circuit configurations as given below.

1. No power connected; no intermittent faults.
2. No power connected; staged intermittent faults through switching action.
3. DC power connected; V = 23.9V; no intermittent faults.
4. DC power connected; V = 23.9V; staged intermittent faults through switching action.
5. DC power connected; V = 23.9V; staged intermittent faults through rubbing action at point A.
6. AC power connected; f = 47.5 kHz; Vp-p = 1V; no intermittent faults.
7. AC power connected; f = 47.5 kHz; Vp-p = 1V; staged intermittent fault through switching action.

These tests were run a number of times and the output to the screen was observed. The tests that showed a direct relationship between the switching or rubbing action and the number of errors were run multiple times and the average error rates were found.

III. Experimental Results

The results are split up into the two separate configurations.

1. Parallel Configuration

The error rates of the parallel circuit with no power connected and with no intermittent fault is given in Table 1. This was used as a baseline to determine the effect of the other experiments on the error rates. When intermittent faults were staged via switching in the circuit without power it was observed that there was an overall increase in the error rates. However, we were unable to observe an increase in the number of errors as a direct result of the switching action. Also, since the NER remained relatively low, it was believed that there was an increase in the number of inherent errors and that accounted for the increase in the error rates. When the DC power supply was connected we observed an increase in the error rates even without intermittent faults as shown in Table 1.

Table 1. The results from the experiments run in the parallel configuration that yielded a notable change in one or more of the error rates.

Experiment	MER	LMR	TER	NER
No power; no intermittent faults (baseline)	9.38	12.83	21.27	0.34
No power; intermittent faults via switching action	17.77	14.92	30.03	0.45
DC power supplied; no intermittent faults	19.13	19.17	34.97	3.71
Intermittent faults via rubbing action	24.14	17.70	36.85	9.18

The MER increased by a small percentage but we notice a large increase in the NER which indicates a large increase in the number of noise errors. It is believed that the DC power supply introduced some form of noise. The generation of noise through switching was detected in the oscilloscope as shown in figure 6 and was found to have a frequency around 30MHz.



Figure 6. The output from the oscilloscope that shows noise being generated along the power line in the parallel configuration by a switching action. The frequency of the generated noise was found to be around 30 MHz.

However, trials did not show an increase in the number of errors as a direct result of the switching action. It is believed that the frequency of the noise being generated is outside the range of the band-pass filter of the PLC chip and is therefore being filtered out. Also, the noise duration is too short (in the order of nanoseconds) to affect the message being transmitted. Finally, we observed that when intermittent faults were generated via a rubbing action there was a large increase in the error rates. We also observed a direct relationship between the amount of messages with errors and the frequency of the intermittent faults. It was seen that the duration of this noise was a lot greater than that being generated by the switching action (in the order of milliseconds). As such it was able to affect the transmitted message. Initial trials conducted with the AC power supply did not yield any notable changes in the error rates.

2. Series Configuration

The error rates of the series circuit with no power connected and with no intermittent fault is given in Table 2. Again, this was used as a baseline to determine the effect of the other experiments on the error rates. Unlike in the parallel configuration there was no notable increase in the error rates when intermittent faults were staged via switching in the circuit with no power. However, just like in the parallel configuration, when the DC power supply was connected an increase in the error rates without intermittent faults was observed as shown in Table 2.

Table 2. The results from the experiments run in the series configuration that yielded a notable change in one or more of the error rates.

Experiment	MER	LMR	TER	NER
No power; no intermittent faults (baseline)	15.28	17.77	30.33	0.20
DC power supplied; no intermittent faults	16.75	18.23	31.93	1.63
Intermittent faults via rubbing action	34.26	20.45	47.70	13.52

Again, the MER increased by a small percentage but we notice a large increase in the NER, which indicates a large increase in the number of noise errors. In the series configuration we were unable to observe the generation of noise through switching in the oscilloscope since there was no change in voltage to be detected. Finally, we saw a dramatic increase in the error rates when intermittent faults were

staged via the rubbing action. Again, the initial trials conducted with the AC power supply did not yield any notable changes in the error rates.

IV. Conclusion

We investigated the feasibility of using power line communication (PLC) to detect intermittent faults in DC wiring systems. We transmitted a known message repeatedly over the system and observed the number of messages that contained errors when received by a receiving station. We were able to successfully simulate intermittent faults via two methods. The first method involved the use of a switch and a very small “switching action” while the second method involved directly rubbing two wires together. The second method was used only to simulate intermittent faults along the electrical wire to the load.

We were able to observe that the switching action in the parallel configuration did in fact generate noise. The frequency of the generated noise was found to be in the 30 MHz range and lasted for a few nanoseconds. The PLC chip uses a carrier frequency of 132.45 kHz and has band-pass filter that filters out all noise outside of 126.45 kHz – 138.45 kHz. Therefore, the frequency of the generated noise is filtered out by the PLC chip. Also, due to the small duration of the generated noise it did not affect the transmitted message enough to generate an error. The short duration of the generated noise also reduced the probability that the message transmission would be affected since the pause between transmissions is extremely long when compared to the length of the generated noise. This problem may be solved by using a PLC chip with a higher carrier frequency or through a method of message transmission other than FSK. We also observed that intermittent faults that occurred along the power line of the DC power supply caused a large increase in the NER. The increase in the NER was also found to be directly related to the frequency of the intermittent faults. The duration of the noise generated by the DC power supply lasted for a lot longer than that generated by the switch (a few milliseconds) and could account for the effect on the transmitted messages. Therefore, generated noise from intermittent faults definitely has an effect in the transmitted messages in a PLC provided that the noise length is sufficiently long. Further investigation into this phenomenon is definitely warranted.

V. Future Work

The first step on any future work will be to redesign the PLC board or change the PLC chip in order to reduce the number of inherent errors. This will allow us to get more accurate results on the effect of intermittent faults on the transmitted messages. Also, the use of the Basic Stamp 2 microcontroller limited the length of the transmitted message since it only provides 26 bytes for general purpose use. By using the Basic Stamp 2 we could not decrease the length of time between message transmissions much further since the microcontroller needed a long time to perform calculations and display data on screen. Increasing the message length and decreasing the transmission pause will increase the probability that the generated noise will affect the message transmissions. The use of a high-end microcontroller could alleviate a lot of the problems we encountered the Basic Stamp. We may also need to use a different PLC chip which uses a carrier frequency closer to the frequency of the generated noise. We can also try using a different transmission technique other than FSK and observe the effect the generated noise has on the error rates. Finally, we need to do further investigation into the effect that intermittent faults have on an AC system. This will be especially useful since some aircraft systems use an AC supply around 48 kHz. Also the same techniques may be applied to finding intermittent faults in homes which use the 60/50 Hz power frequencies.

VI. References

- [1] V. B. Prasad, "The Effects of Intermittent Faults in the Reliability of Digital Systems", *IEEE Southeastcon '90. Proceedings.*, vol 3. pp. 948-952, April 1990.
- [2] B. A. Sorenson, G. Kelly, A. Sajecki, and P. W. Sorenson, "An Analyzer for Detecting Intermittent Faults in Electronic Devices", *IEEE AUTOTESTCON '94. Conference Proceedings.*, pp. 417-412, Sept. 1994.
- [3] "Locating Faults in Electrical Wiring" from Live Wire Test Labs, Inc.
<http://www.livewiretest.com/Personal%20Web%20Page.htm>
- [4] William G. Linzey, et al, "A Risk Analysis of a Wire Failure Potential in the Aircraft Industry", *8th Joint NASA/FAA/DoD Conference on Aging Aircraft*, Feb 2005.
- [5] Paul Smith, Cynthia Furse, and Jacob Gunther, "Analysis of Spread Spectrum Time Domain Reflectometry for Wire Fault Location", *IEEE Sensors Journal*, vol. 5, no. 6, Dec 2005.
- [6] I. Hakki Cavdar, "Performance Analysis of FSK Power Line Communications Systems Over the Time-Varying Channels: Measurements and Modeling", *IEEE Transactions on Power Delivery*, vol. 19, issue 1, pp. 111-117, Jan 2004.
- [7] Chun-Hung Liu, Eric Wade, and H. Harry Asada, "Reduced-Cable Smart Motors Using DC Power Line Communication", *IEEE International Conference on Robotics and Automation. Proceedings.*, vol 4., pp. 3831-3838, 2001.
- [8] V. Taylor, and M. Faulkner, "Line Monitoring and Fault Location using Spread Spectrum on Power Line Carrier", *IEE Electronics Letters*, vol. 143, issue 5, pp. 427-434, Sep 1996.